

Errata

Title & Document Type: e4400 ESG-D Series Service Guide

Manual Part Number: e4400-90014

Revision Date: July 1997

HP References in this Manual

This manual may contain references to HP or Hewlett-Packard. Please note that Hewlett-Packard's former test and measurement, semiconductor products and chemical analysis businesses are now part of Agilent Technologies. We have made no changes to this manual copy. The HP XXXX referred to in this document is now the Agilent XXXX. For example, model number HP8648A is now model number Agilent 8648A.

About this Manual

We've added this manual to the Agilent website in an effort to help you support your product. This manual provides the best information we could find. It may be incomplete or contain dated information, and the scan quality may not be ideal. If we find a better copy in the future, we will add it to the Agilent website.

Support for Your Product

Agilent no longer sells or supports this product. You will find any other available product information on the Agilent Test & Measurement website:

www.tm.agilent.com

Search for the model number of this product, and the resulting product page will guide you to any available information. Our service centers may be able to perform calibration if no repair parts are needed, but no other support from Agilent is available.

HP ESG-D Series
Signal Generators
Service Guide

Service Guide
HP ESG-D Series Signal Generators

Serial Number Prefixes:

HP ESG-D1000A, US3723 and below
HP ESG-D2000A, US3723 and below
HP ESG-D3000A, US3723 and below
HP ESG-D4000A, US3723 and below



HP Part No. E4400-90014

Printed in USA
Print Date: July 1997

©Copyright Hewlett-Packard Company 1997. All Rights Reserved. Reproduction, adaptation, or translation without prior written permission is prohibited, except as allowed under the copyright laws.

1400 Fountaingrove Parkway, Santa Rosa, CA 95403-1799, USA

Contents

1 Initial Troubleshooting and Overall Block Diagram

Before You Begin Troubleshooting	1-2
Using this Service Guide to Troubleshoot	1-3
Equipment Required for Troubleshooting	1-4
Initial Troubleshooting.....	1-5
Overall Block Diagram.....	1-17
Overall Block Diagram (Option 1EH).....	1-19
Overall Block Diagram (Options UN3 & UN4).....	1-21

2 Assembly-Level Troubleshooting with Block Diagrams

Before You Begin Troubleshooting	2-2
Using the Procedures in this Chapter.....	2-3
A9 Output Board.....	2-5
A9 Output Board Block Diagram	2-7
A11 Reference Board.....	2-9
A11 Reference Board Block Diagram	2-11
A12 Synthesizer/Doubler Board.....	2-13
A12 Synthesizer/Doubler Board Block Diagram	2-15
A14 CPU/Motherboard.....	2-17
A14 CPU/Motherboard Block Diagram (1 of 2)	2-19
A14 CPU/Motherboard Block Diagram (2 of 2)	2-21
AT1 Attenuator/RPP Block Diagram.....	2-23

Contents

A7 Baseband Generator Board Block Diagram (Option 1EH)	2-25
A7 Baseband Generator Board Block Diagram (Options UN3 & UN4)	2-27
A8 Data Generator Board Block Diagram (Options UN3 & UN4)	2-29
Interconnects Block Diagram - Power Supply and Ground (1 of 2)	2-31
Interconnects Block Diagram - Power Supply and Ground (2 of 2)	2-33
Interconnects Block Diagram - Modulation and Signal (1 of 2)	2-35
Interconnects Block Diagram - Modulation and Signal (2 of 2)	2-37
3 Replaceable Parts	
Ordering Information.....	3-2
Save Money with Rebuilt-Exchange Assemblies.....	3-4
Abbreviations Used in Part Descriptions	3-6
Major Assemblies	3-8
Cables	3-16
Hardware and Other Instrument Parts	3-34
Miscellaneous	3-56
4 Assembly Replacement	
Before You Replace an Assembly	4-2
Assemblies That You Can Replace.....	4-3
Instrument Cover	4-4
Front Panel.....	4-6
Front Panel (Option 1EM).....	4-10

Contents

Rear Panel	4-14
Rear Panel (Option 1EM)	4-18
A1 Front Panel Board	4-22
A2 Display	4-24
A2DS1 Fluorescent Lamp	4-26
A3 Inverter	4-28
A4 Power Supply	4-30
A4 Power Supply (Option 1EM)	4-34
A7 Baseband Generator Board (Option 1EH)	4-38
A7 Baseband Generator Board (Options UN3 & UN4)	4-40
A8 Data Generator Board (Options UN3 & UN4)	4-42
A9, A11, and A12 Daughterboard Card Cage Boards	4-44
A14 CPU/Motherboard	4-46
A14BT1 Battery	4-50
A15 Daughterboard	4-52
A16 Line Module	4-56
A17 Rear Panel Interface Board (Options 1EH, UN3, UN4)	4-58
AT1 Electronic Attenuator/RPP	4-60
B1 Small Fan Assembly	4-62
B2 Large Fan Assembly	4-64
W11, W12, and W14 Semi-Rigid Cables	4-66

Contents

5 Post-Repair Procedures

Performance Tests.....	5-2
Adjustments.....	5-4

6 Error Messages

Error Messages.....	6-2
Querying the Error Queue.....	6-4
Error Numbers.....	6-5
No Error.....	6-6
SCPI Standard Error Messages.....	6-7
Command Error.....	6-8
Execution Error.....	6-13
Device-specific Error.....	6-20
Query Error.....	6-22
ESG-D Series Signal Generator Instrument-Specific Error Messages.....	6-24

7 Options and Accessories

Signal Generator Options.....	7-2
Signal Generator Accessories.....	7-7
Upgrade and Retrofit Kits.....	7-8

8 Contacting Hewlett-Packard

Before Contacting HP.....	8-2
---------------------------	-----

Contents

Calling HP Sales and Service Offices	8-3
Returning Your Signal Generator for Service.....	8-5
Blue Repair Tags.....	8-7
9 Safety and Regulatory	
Safety Notes.....	9-2
General Safety Considerations.....	9-3
Lithium Battery Disposal.....	9-4
Warranty.....	9-5
Assistance	9-6
Notice.....	9-7
Certification	9-8
Index	

Contents

1 Initial Troubleshooting and Overall Block Diagram

This chapter will help you begin troubleshooting your signal generator. The procedures in this chapter primarily check your instrument for failures that affect the power supplies or CPU function. An overall block diagram of your signal generator is at the end of this chapter.

Before You Begin Troubleshooting

Avoid Personal Injury

WARNING: These servicing instructions are for use by qualified personal only. To avoid electrical shock, do not perform any servicing unless you are qualified to do so.

WARNING: The opening of covers or removal of parts is likely to expose dangerous voltages. Disconnect the product from all voltage sources while it is being opened.

WARNING: The detachable power cord is the instrument disconnecting device. It disconnects the mains circuits from the mains supply before other parts of the instrument. The front panel switch is only a standby switch and is not a LINE switch.

WARNING: The power cord is connected to internal capacitors that may remain live for 5 seconds after disconnecting the plug from its power supply.

Prevent ESD Damage

CAUTION: Many of the assemblies in this instrument are very susceptible to damage from ESD (electrostatic discharge). Perform service procedures only at a static-safe workstation and wear a grounding strap.

Using this Service Guide to Troubleshoot

Several chapters in this service guide work together to help you troubleshoot and repair your signal generator.

Chapter 1, “Initial Troubleshooting and Overall Block Diagram,” helps you get started with some basic checks and instructions.

Chapter 2, “Assembly-Level Troubleshooting with Block Diagrams,” helps you identify and verify the failed assembly.

Chapter 3, “Replaceable Parts,” will help you locate the failed assembly or cable in the signal generator and also provides you with part numbers and ordering information.

Chapter 4, “Assembly Replacement,” gives you step-by-step instructions on how to remove and replace an assembly.

Chapter 5, “Post-Repair Procedures,” lists the performance tests and adjustments that must be performed after an assembly has been repaired or replaced.

Equipment Required for Troubleshooting

The following table lists the equipment required to troubleshoot your signal generator.

Table 1-1. Recommended Test Equipment

Equipment	Critical Specifications for Equipment Substitution	Recommended Model
Digital Multimeter	Input Resistance: $\leq 10\text{ M}\Omega$ Accuracy: $\pm 10\text{ mV}$ on 100 V range	HP 3458A

Initial Troubleshooting

Perform the following troubleshooting steps in the order they are presented. If you are unable to identify the failed assembly, go to Chapter 2, "Assembly-Level Troubleshooting with Block Diagrams," for further instruction.

NOTE: *Do not attempt to replace any fuses within the power supply to correct a problem with your signal generator. If you determine that the power supply is the failed assembly, replace the power supply.*

Step 1: Observe the Front and Rear Panel LEDs

Observing the LEDs on the front and rear panel of the signal generator will determine if there is a catastrophic failure in the power supply assembly.

1. Ensure the signal generator is plugged in (*do not* switch the power on) and verify that the yellow LED on both the front and rear panels is lit. Refer to Figure 1-1 for LED locations. A lit yellow LED (+15V_STBY) indicates that line voltage is present.
2. Power on the signal generator and verify that the green LED on both the front and rear panels is lit. A lit green LED indicates the power supply has received an "ON" command. The ON/OFF switch toggles a flip-flop latch which biases the proper transistors in the LED control circuit. This circuit is powered by VBAT, the battery-backed SRAM supply, so that the on-off state is "remembered" even when the instrument is unplugged.

Initial Troubleshooting and Overall Block Diagram
Initial Troubleshooting

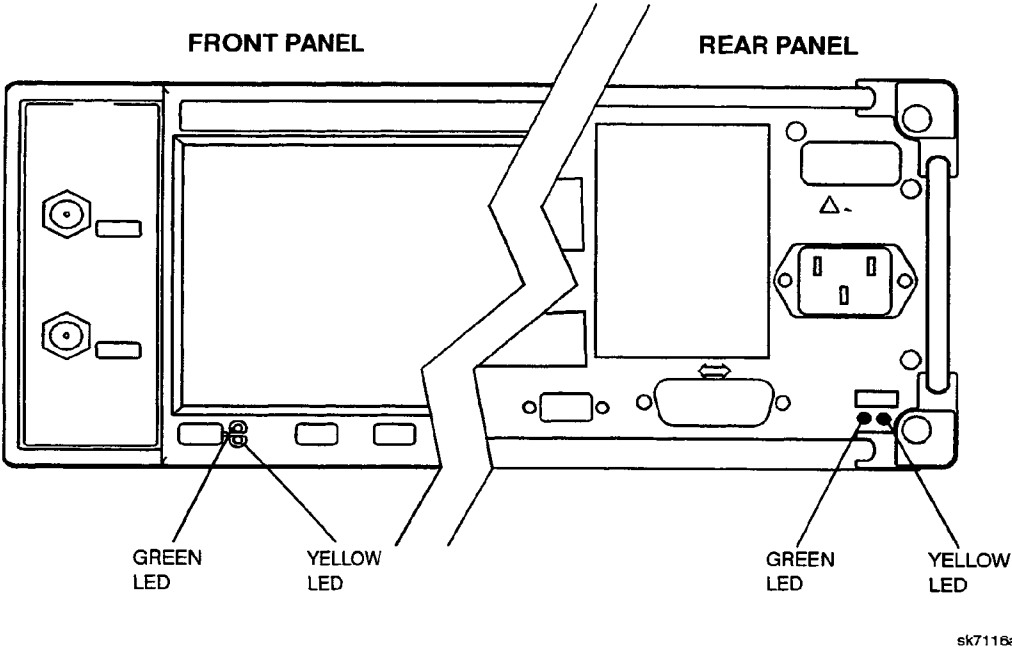

Figure 1-1. LED Locations on the Rear Panel

Step 2: Power On the Signal Generator and Check for Error Messages

This procedure verifies that the signal generator powers up and that the internal instrument check identifies no errors. The internal check evaluates the correctness of operation and returns an error message if a problem is detected.

1. Switch on the signal generator. Let the signal generator warm up for at least five minutes.

NOTE:

For signal generators with Option 1E5, **ERROR 514, Reference Oven Cold** will occur whenever the signal generator is powered up within five minutes of being connected to AC line power. The **OVEN COLD** annunciator and the **ERR** annunciator will both turn on. The **OVEN COLD** annunciator will automatically clear after approximately five minutes. The error queue *cannot* be cleared, however, until the **OVEN COLD** annunciator has turned off.

2. Cycle the power to the signal generator and verify that the green LED on both the front and rear panels is lit. Refer to Figure 1-1.
3. When the display is lit, check to see if the **ERR** annunciator is turned on.
4. If the **ERR** annunciator is turned on, review the error messages in the queue by pressing **Utility, Error Info, View Next Error Message**. The first error message in the queue will be shown in the text area of the display. Refer to Chapter 6, "Error Messages," for descriptions of error messages.

If there is more than one error message (each message will be designated as 1 of *n*), continue pressing the **View Next Error Message** softkey until you have seen and recorded all of the messages.
5. If you were able to resolve all of the error messages, press **Utility, Error Info, Clear Error Queue(s)** to delete the list of error messages.

Step 3: Functional Check the Front Panel Keys and Display

1. Press various front panel hardkeys and softkeys to verify they function as expected.
2. Use the contrast keys to verify that the display can be lightened and darkened. Refer to Figure 1-2.

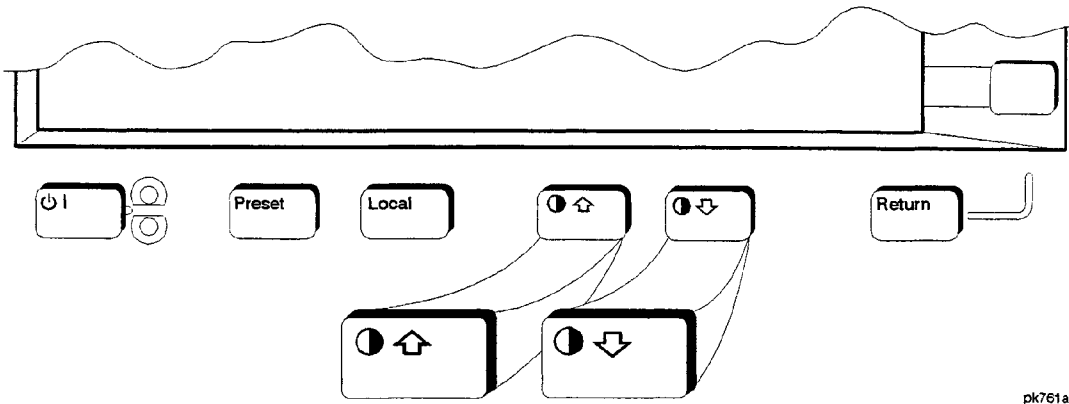

pk761a

Figure 1-2. Contrast Keys

Step 4: Visually Check the Individual Voltage Supplies

1. Unplug the signal generator and remove the instrument cover. Refer to Chapter 4, "Assembly Replacement," for removal instructions.
2. Expose the motherboard by removing the top cover. It is secured by 11 screws.
3. Plug in the signal generator and allow it to warm up for at least five minutes.
4. If possible, clear the error queue(s) of messages. Press **Utility, Error Info, Clear Error Queue(s)**.
5. On the motherboard, locate the 10 LEDs that correspond to the individual voltage supplies (see Figure 1-3). Verify that all the LEDs are lit. If one or more LEDs are off, proceed to Step 6: Isolate the Failed Assembly.

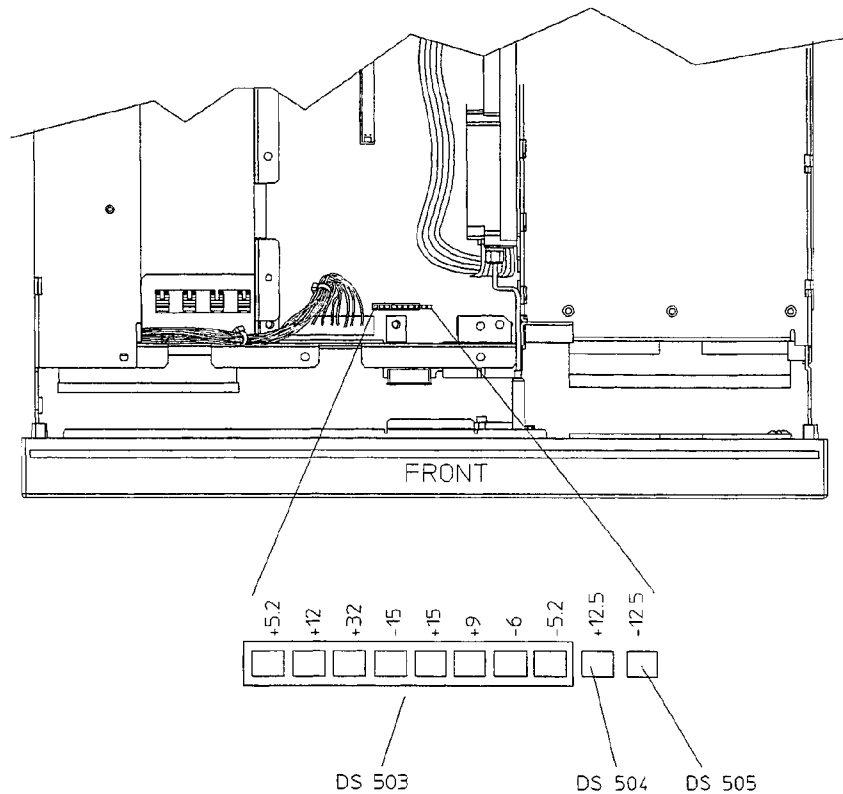

sk794a

Figure 1-3. LED Locations on the Motherboard

Step 5: Measure the Individual Voltage Supplies

The voltages supplied as inputs from the power supply via J6 to the motherboard are +15V (TP502), +15V standby (+15_STBY), -15 V (TP503), +12V (TP505), and +5.2V (TP302). DGND (TP301) is associated with these supplies.

The -6V (TP508) and -5.2 (TP509) supplies receive their input from the +5.2V digital supply (5.2VD - TP506). The +5.2V digital line is filtered to prevent the switching power supply noise from being induced onto the +5.2VD supply lines. The -6V is a bias voltage for circuits on the output board and other RF circuitry. The -5.2V is used by the emitter coupled logic (ECL) digital ICs. The LCD display driver voltage (VLCD), a -14V to -24V source, also receives input from the +5.2VD supply.

The input to the +32V supply (TP504) is the +12V supply. The +32V supply is used by the synthesizer/doubler assembly. This supply also includes an LC noise filter.

The +12.5V regulated supply (TP510) originates from the +15V input. The -12.5V regulated supply (TP511) originates from the -15V input. These two supplies are used by the solid-state attenuator and the reverse power protection (RPP). The +10V reference (TP501) originates from the +15V input. The +9V supply (TP507) originates from the +10V reference and the +12V supply.

1. Unplug the signal generator and turn it upside-down.
2. Expose the motherboard by removing the bottom cover. It is secured by 15 screws.
3. Plug in the signal generator.
4. Measure the voltage of each supply to verify they are within the tolerances listed in Table 1-2. The voltage supply test point locations are shown in Figure 1-4. If all the voltages are within tolerance, proceed to Step 7: Check for Basic CPU Functionality.

Table 1-2. Voltage Supply Tolerances

Test Point	Supply Voltage	Tolerance
J6 (pins 2, 3, 12, 13)	+5.2	+/- 3%
J6 (pin 20)	+15	+/- 3%
J6 (pin 18)	-15	+/- 3%
J6 (pin 19)	+12	+/- 3%
J6 (pin 17)	+15 STBY	+/- 5%
TP301	DGND	N/A
TP302	+5.2V	+/- 3%
TP501	+10V_REF	+/- 3%
TP502	+15V	+/- 3%
TP503	-15V	+/- 3%
TP504	+32V	+/- 4%
TP505	+12V	+/- 3%
TP506	+5.2VD	+/- 4%
TP507	+9V	+/- 4%
TP508	-6V	+/- 4%
TP509	-5.2V	+/- 4%
TP510	+12.5V	+/- 4%
TP511	-12.5V	+/- 4%

Initial Troubleshooting and Overall Block Diagram
Initial Troubleshooting

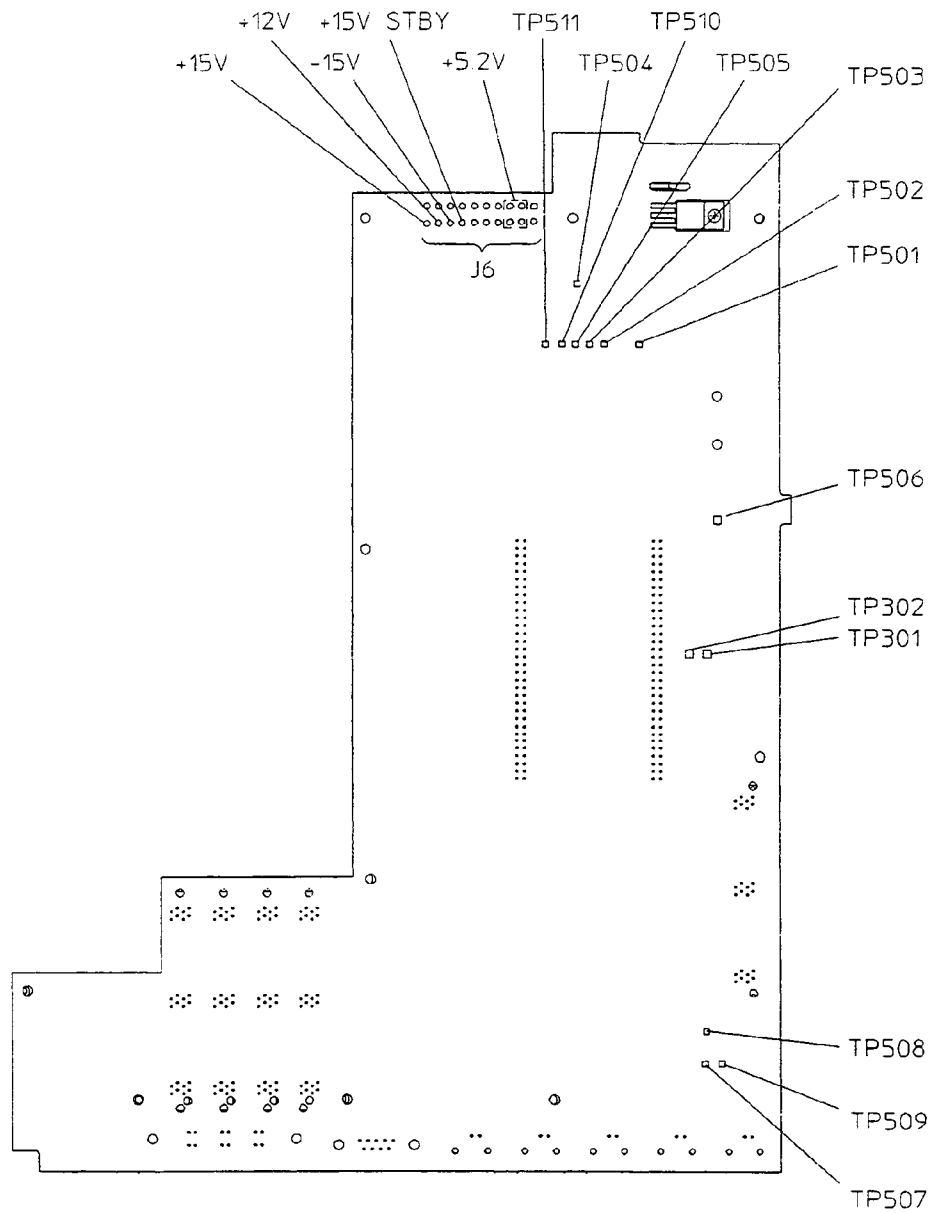

sk7117a

Figure 1-4. Motherboard Test Point Locations

Step 6: Isolate the Failed Assembly

1. Switch off the signal generator.
2. Remove or disconnect an assembly. Below is a suggested order of removal/disconnection based upon ease.
 - a A7 Baseband Generator Board (Options 1EH, UN3, UN4)
 - b A8 Data Generator Board (Options UN3, UN4)
 - c A1W1 Front Panel Ribbon Cable
 - d A3W1 Inverter Wire Bundle
 - e W10 Display Ribbon Cable
 - f W13 Attenuator/RPP Ribbon Cable
 - g B1W1 Fan Cable (disconnect *only* temporarily)
 - h B1W2 Fan Cable (disconnect *only* temporarily)
 - i A9 Output Board
 - j A11 Reference Board
 - k A12 Synthesizer/Doubler Board

NOTE: Refer to Chapter 3, "Replaceable Parts," for information on locating assemblies. Refer to Chapter 4, "Assembly Replacement," for information on removing or disconnecting assemblies.

3. Switch on the signal generator and check the voltage supply LEDs (see Figure 1-3). If the LEDs are lit, you have likely identified the failed assembly. If one or more LEDs are still off, switch off the signal generator and replace/reconnect the assembly and repeat this procedure.

Initial Troubleshooting

Step 7: Check for Basic CPU Functionality

The Digital Signal Processor (DSP) performs a self-diagnostic test at power up. If the DSP is not working, the CPU reports an error.

If the DSP does not seem to be working and the CPU did not report the error, then check the CLK_OUT signal at TP701. It should be a 16 MHz signal. (Refer to Figure 1-5.)

The eight LEDs of DS201 (see Figure 1-5) indicate the status of the boot and flash ROM for the CPU. The LEDs form a binary code that can be described as a tow digit hexadecimal code. Table 1-3 shows the test sequence and the LED pattern (binary representation) of the test that is running. If an error occurs and the test is halted the LED pattern will indicate which self test halted the process. The LED closest to R201 is the place holder for the Least Significant Bit (LSB) in the pattern.

Table 1-3. Sequence for DSP Self-Diagnostic Tests

Test Description	Hexadecimal Code	Binary Representation MSB LSB
LEDs at start of test	FF	1111 1111
Checksum test	FE	1111 1110
Bootrom RAM test	FD	1111 1101
RAM test	FC	1111 1100
I/O bus test	FB	1111 1011
Main firmware checksum test	FA	1111 1010
CPU test	AA	1010 1010
Test done and OK	00	0000 0000

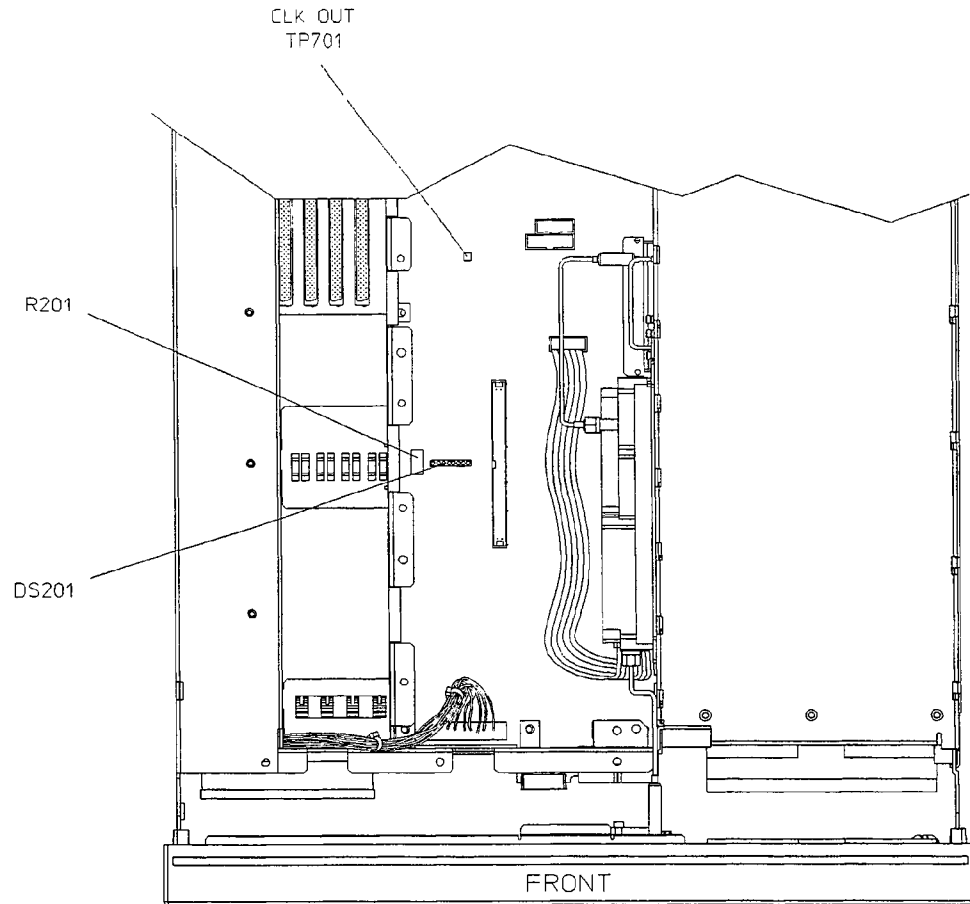

sk7118a

Figure 1-5. Location of TP701 and DS201 on CPU/Motherboard

Initial Troubleshooting and Overall Block Diagram
Initial Troubleshooting



HP ESG-D SERIES OVERALL BLOCK DIAGRAM
(OPTION 1EH)

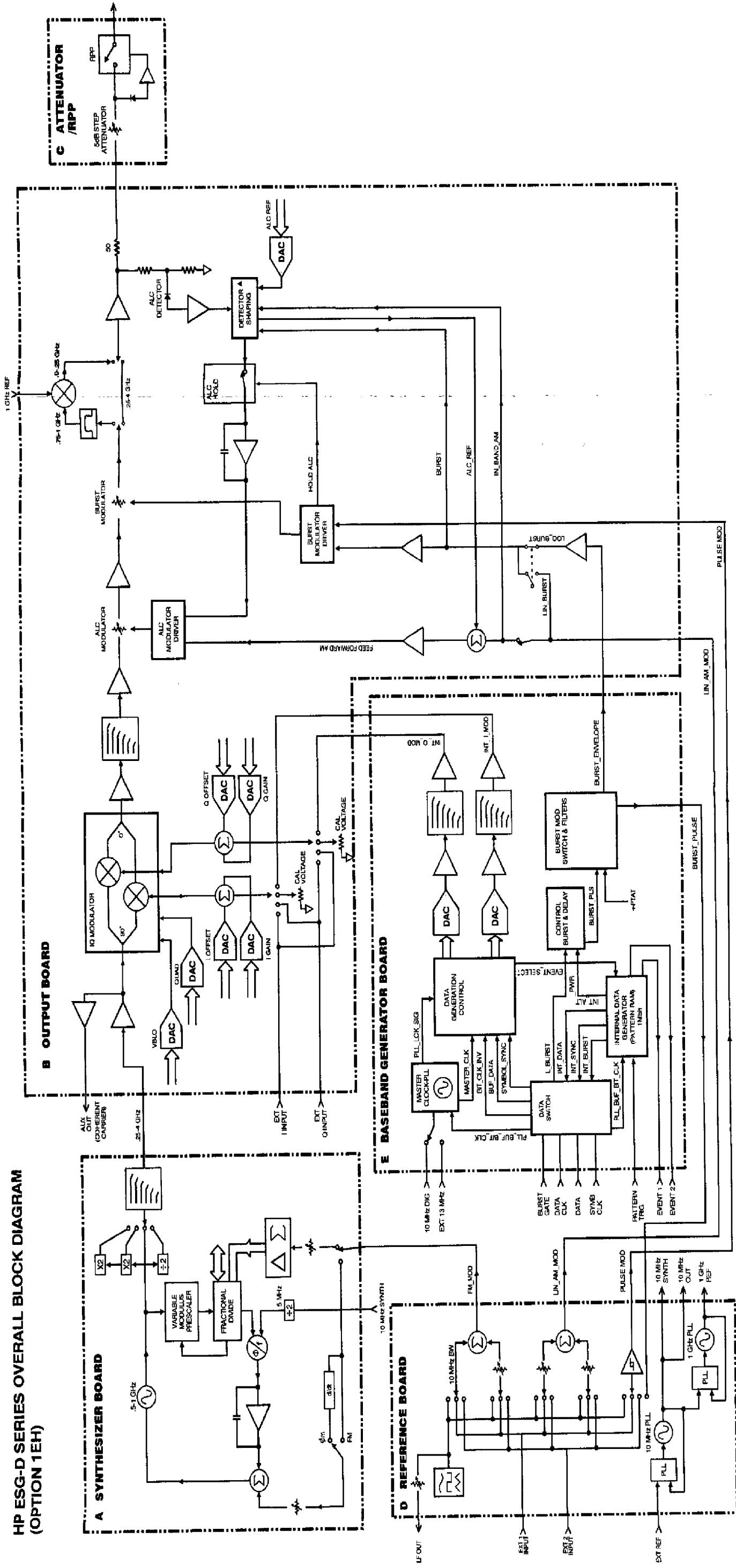

HP ESG-D SERIES OVERALL BLOCK DIAGRAM (OPTION 1EH)

2 Assembly-Level Troubleshooting with Block Diagrams

This chapter will help you test and troubleshoot the major assemblies of your signal generator. Block diagrams are also provided for each of the assemblies.

Before You Begin Troubleshooting

Avoid Personal Injury

WARNING: These servicing instructions are for use by qualified personal only. To avoid electrical shock, do not perform any servicing unless you are qualified to do so.

WARNING: The opening of covers or removal of parts is likely to expose dangerous voltages. Disconnect the product from all voltage sources while it is being opened.

WARNING: The detachable power cord is the instrument disconnecting device. It disconnects the mains circuits from the mains supply before other parts of the instrument. The front panel switch is only a standby switch and is not a LINE switch.

WARNING: The power cord is connected to internal capacitors that may remain live for 5 seconds after disconnecting the plug from its power supply.

Prevent ESD Damage

CAUTION: Many of the assemblies in this instrument are very susceptible to damage from ESD (electrostatic discharge). Perform service procedures only at a static-safe workstation and wear a grounding strap.

Using the Procedures in this Chapter

This chapter contains a troubleshooting procedure for each of the following assemblies in your signal generator:

- A9 Output Board
- A11 Reference Board
- A12 Synthesizer Board
- A14 CPU/Motherboard

Each procedure consists of the following:

- A table listing the tests in the order they should be performed. The table also provides test conditions and expected node voltages for each test.
- A block diagram of the assembly.

You Will Need Software

To perform the tests in this chapter you must use the service software that came with your signal generator. The service software has a utility program that measures and displays the node voltages for each test. Refer to your signal generator's calibration guide for information on using the software.

Additional Block Diagrams

The following block diagrams can be found at the end of this chapter:

- AT1 Attenuator/RPP
- A7 Baseband Generator Board - Option 1EH
- A7 Baseband Generator Board - Options UN3 & UN4
- A8 Data Generator Board - Options UN3 & UN4
- Power Supply and Ground Interconnects
- Modulation & Signal Interconnects

Assembly-Level Troubleshooting with Block Diagrams
Using the Procedures in this Chapter



A9 Output Board

NOTE:

The node voltages given in the following table are approximate values based on a sample of signal generators. Your signal generator may not reflect these exact values. Additionally, the resolution of these values varies from node to node. As a guideline, interpret your measurements based on the number of decimal places shown for the expected voltage.

A9 Output Board Abus Nodes (1 of 2)

Test Conditions	Node Voltages (Corrected Values in Vdc)						
	ALC_MOD	BURST_MOD	ALC_DET	POW_REF_1	POW_REF_2	LOOP_INT	PTAT
PRESET; 0 dBm; RF On; No Modulation	≈0.7	≈19	≈-0.08	≈-1.2	≈-0.5	≈1	≈8.5 to 9.9
PRESET; 0 dBm; RF Off; No Modulation	≈0.1	≈19	0.0	≈-1.2	≈-0.5	≈-10	≈8.5 to 10.9
PRESET; 20 dBm; RF On (Unleveled)	≈20	≈19	≈-0.4	≈-0.4	≈-1	≈12	
Frequency Set to heterodyne Band; PRESET; Frequency ≤ 249.9 MHz; 0 dBm; RF On; No Modulation	≈0.4	≈19	≈-0.05	≈-1.1	≈-0.3	≈0.0	≈8.5 to 10.9
+5.0 Vdc applied to Q INPUT: PRESET; 0 dBm; RF On; I/Q On; I/Q Source EXT I/Q; I Input = No Connection; Burst Envelope On; If -0.5Vdc is applied to Q INPUT, the Q node changes to negative voltage	≈0.9 (20 w/ no Q Input)	≈4.8	≈-0.08 (≈-0.1 w/ no Q Input)			≈1.3 (≈12 w/ no Q Input)	
+1 Vdc Applied to EXT 1 INPUT: PRESET; 0 dBm; RF On; AM On; AM Depth 100%; AM Source Ext 1 DC							

Assembly-Level Troubleshooting with Block Diagrams
A9 Output Board

A9 Output Board Abus Nodes (2 of 2)

Test Conditions	Node Voltages (Corrected Values in Vdc)						
	I	Q	PRE_LEVEL	QUAD	GAIN_DET	GRD	REF_AM
PRESET; 0 dBm; RF On; No Modulation	≈0.8	≈0	≈-2	≈-2	≈-0.2	≈0.00	≈0.3
PRESET; 0 dBm; RF Off; No Modulation	≈0.8	≈0	≈-2	≈-2	≈-0.2	≈0.00	≈0.3
PRESET; 20 dBm; RF On (Unleveled)							
Frequency Set to heterodyne Band; PRESET; Frequency ≤ 249.9 MHz; 0 dBm; RF On; No Modulation	≈0.5	≈0	≈2	≈-3	≈-0.2	≈0.00	≈0.2
+5.0 Vdc applied to Q INPUT: PRESET; 0 dBm; RF On; I/Q On; I/Q Source EXT I/Q; I Input = No Connection; Burst Envelope On; If -0.5Vdc is applied to Q INPUT, the Q node changes to negative voltage	≈0	≈0.8			≈0.2 (0.0 w/ no Q Input)		
+1 Vdc Applied to EXT 1 INPUT: PRESET; 0 dBm; RF On; AM On; AM Depth 100%; AM Source Ext 1 DC							≈1

A9 OUTPUT BLOCK DIAGRAM

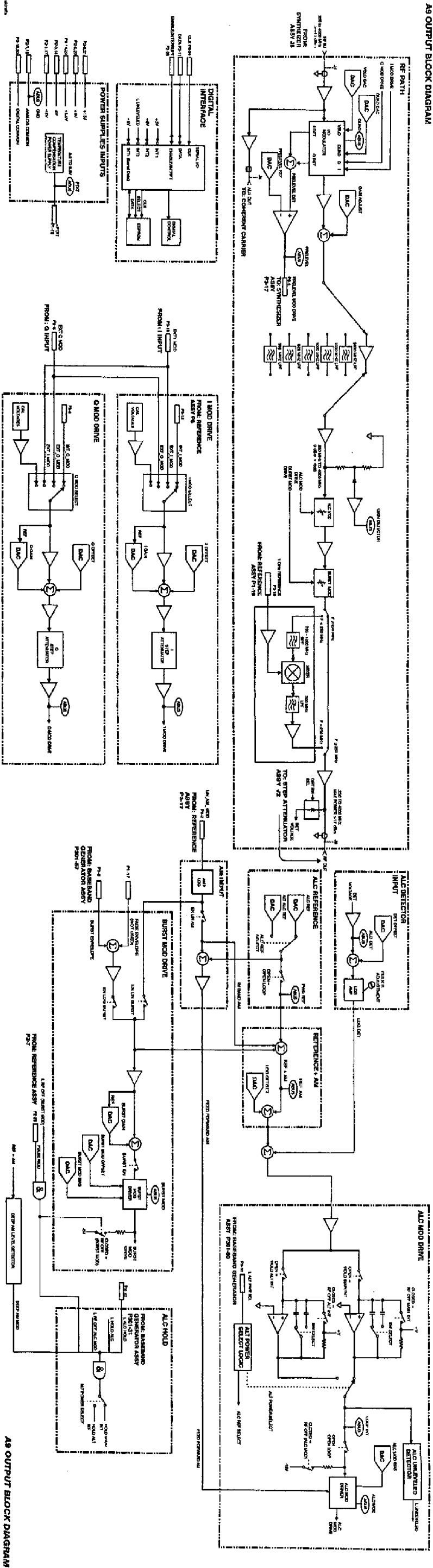

A9 OUTPUT BLOCK DIAGRAM

A11 Reference Board

NOTE:

The node voltages given in the following table are approximate values based on a sample of signal generators. Your signal generator may not reflect these exact values. Additionally, the resolution of these values varies from node to node. As a guideline, interpret your measurements based on the number of decimal places shown for the expected voltage.

A11 Reference Board Abus Nodes

Test Conditions	Node Voltages (Corrected Values in Vdc)							
	MOD1_OUT	MOD2_OUT	VTUNE	MOD1_PK	MOD2_PK	LIN_AM	1GHZ_DET	FM_MOD
PRESET; No Modulation	0.00	0.00	2 to 4	< 0.5	< 0.5	0.00	0.0	< 0.3
Frequency Set to Heterodyne Band: PRESET; Frequency ≤ 249.9 MHz; No Modulation			2 to 4				> 0.15	
+1 Vdc Applied to EXT 1 INPUT: PRESET; FM On; FM Source Ext 1 DC	≈ -1.9	0.00	2 to 4	< 0.5	< 0.5		0.0	≈ 2.2
+1 Vdc Applied to EXT 2 INPUT: PRESET; FM On; FM Source Ext 2 DC	≈ 0	0.00	2 to 4	≈ 7.5	< 0.5		0.0	≈ 0
1 Vpp @ 1 kHz Applied to EXT 1 INPUT: PRESET; FM On; FM Source Ext 1 AC	≈ -1.9	0.00	2 to 4	< 0.5	< 0.5	≈ 2.0	0.0	
1 Vpp @ 1 kHz Applied to EXT 2 INPUT: PRESET; FM On; FM Source Ext 2 AC	≈ 0	0.00	2 to 4	≈ 7.5	< 0.5	≈ 0	0.0	
+1 Vdc Applied to EXT 1 INPUT: PRESET; AM On; AM Depth 100%; AM Source Ext 1 DC	0.00	≈ -1.9	2 to 4	< 0.5	< 0.5		0.0	≈ 2.2
+1 Vdc Applied to EXT 2 INPUT: PRESET; AM On; AM Depth 100%; AM Source Ext 2 DC	0.00	≈ 0	2 to 4	< 0.5	≈ 7.5		0.0	≈ 0

Assembly-Level Troubleshooting with Block Diagrams
A11 Reference Board

A11 Reference Board Abus Nodes

Test Conditions	Node Voltages (Corrected Values in Vdc)							
	MOD1_OUT	MOD2_OUT	VTUNE	MOD1_PK	MOD2_PK	LIN_AM	1GHZ_DET	FM_MOD
1 Vpp @ 1 kHz Applied to EXT 1 INPUT: PRESET; AM On; AM Depth 100%; AM Source Ext 1 AC	0.00	≈ -1.9	2 to 4	< 0.5	< 0.5	≈ 2.0	0.0	
1 Vpp @ 1 kHz Applied to EXT 2 INPUT: PRESET; AM On; AM Depth 100%; AM Source Ext 2 AC	0.00	≈ 0	2 to 4	< 0.5	≈ 7.5	≈ 0	0.0	

AT1 REFERENCE BLOCK DIAGRAM

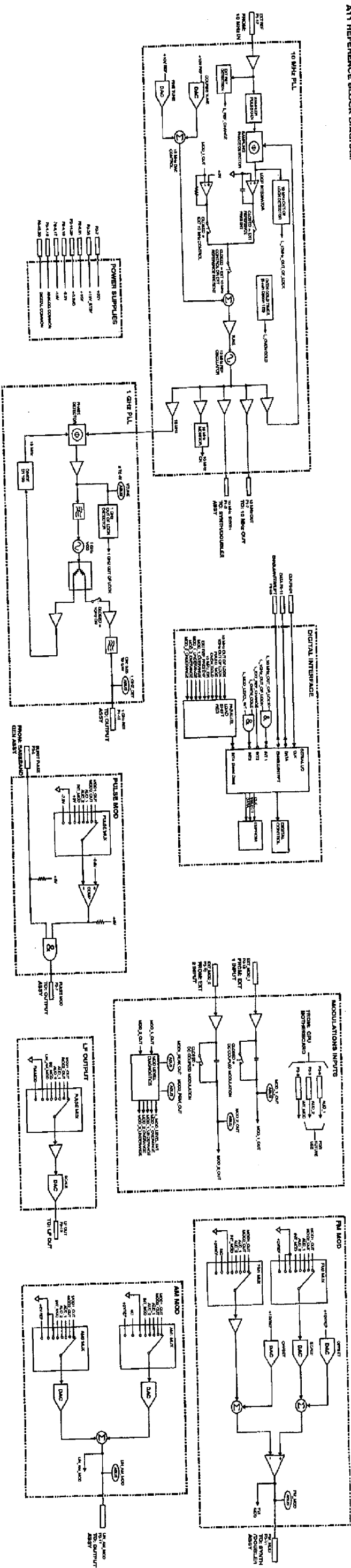

AT1 REFERENCE BLOCK DIAGRAM

A12 Synthesizer/Doubler Board

NOTE: The node voltages given in the following table are approximate values based on a sample of signal generators. Your signal generator may not reflect these exact values. Additionally, the resolution of these values varies from node to node. As a guideline, interpret your measurements based on the number of decimal places shown for the expected voltage.

A12 Synthesizer/Doubler Board Abus Nodes

Test Conditions	Node Voltages (Corrected Values in Vdc)					
	F2	RF_OUT	TUNE	LOOP	10V	FM
PRESET; FREQUENCY 500.000001 MHz; No Modulation	≈4	-0.4 to -0.7	3.0 to 4.8	≈-0.6	9.9 to 10.1	<0.2
PRESET; FREQUENCY 750 MHz; No Modulation	≈5.5	-0.4 to -0.7	10.2 to 12.8	≈-1.5	9.9 to 10.1	<0.2
PRESET; FREQUENCY 1000 MHz; No Modulation	≈7.2	-0.4 to -0.7	17.7 to 23.2	≈-5.5	9.9 to 10.1	<0.2
+1 Vdc Applied to EXT 1 INPUT; PRESET; FM On; FM Source Ext 1 DC						≈-2.0
+1 Vdc Applied to EXT 1 INPUT; PRESET; FREQUENCY < 250 MHz; FM On; FM Source Ext 1 DC						≈-2.0

Assembly-Level Troubleshooting with Block Diagrams
A12 Synthesizer/Doubler Board



A12 SYNTH/DOUBLER BLOCK DIAGRAM

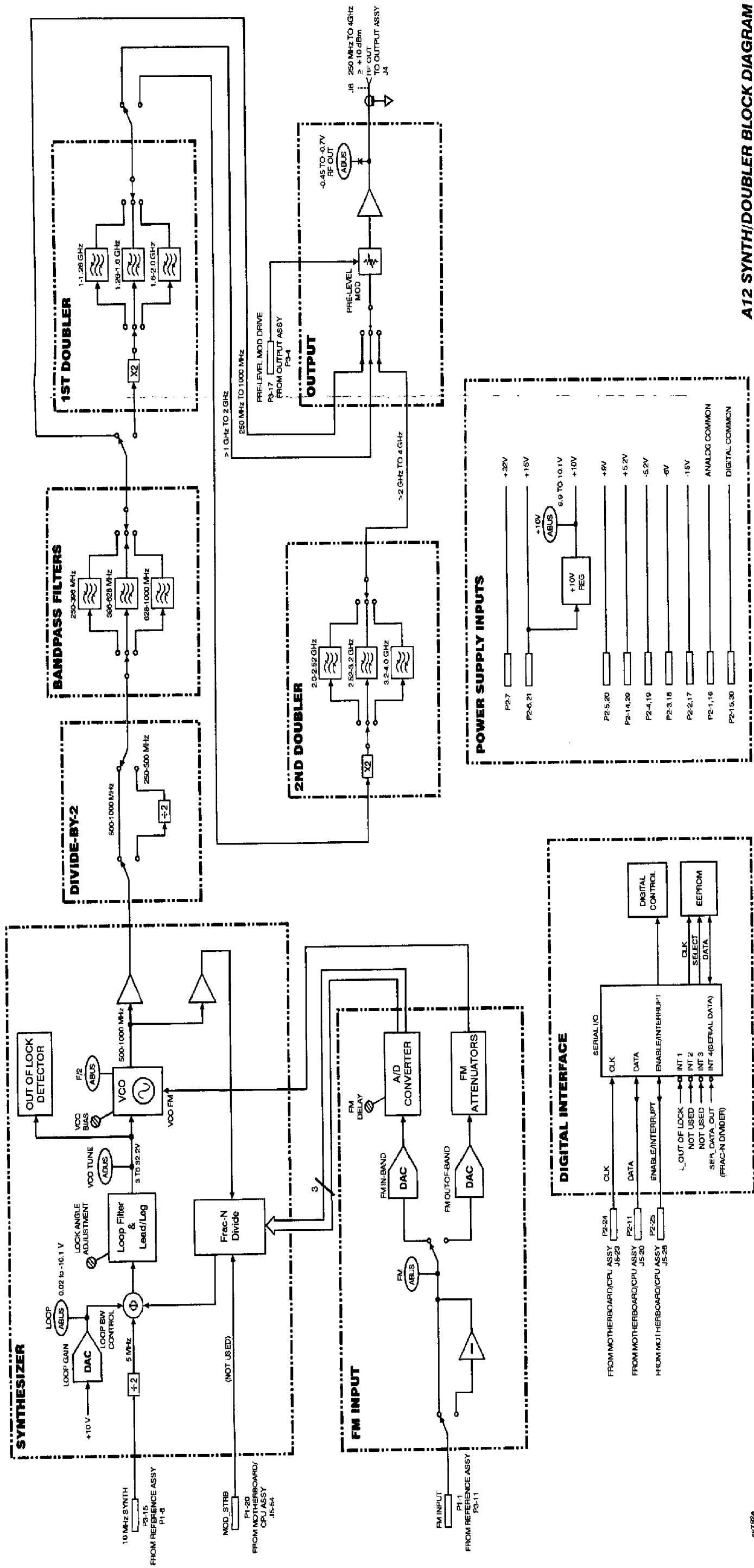

A12 SYNTH/DOUBLER BLOCK DIAGRAM

A14 CPU/Motherboard

NOTE:

The node voltages given in the following table are approximate values based on a sample of signal generators. Your signal generator may not reflect these exact values. Additionally, the resolution of these values varies from node to node. As a guideline, interpret your measurements based on the number of decimal places shown for the expected voltage.

A14 CPU/Motherboard Abus Nodes

Test Conditions	Node Voltages (Corrected Values in Vdc)							
	DISP	LCD	INT_MOD	P10V_REF	M6V	M5V	P9V	ACOM
PRESET;		-5.3	0.00	10	-6.0	-5.2	9.0	0.00
PRESET; Vary Display Brightness 1 to 50	-0.4 to -1.3							

Assembly-Level Troubleshooting with Block Diagrams
A14 CPU/Motherboard



A14 CPU/MOTHERBOARD BLOCK DIAGRAM (1 OF 2)

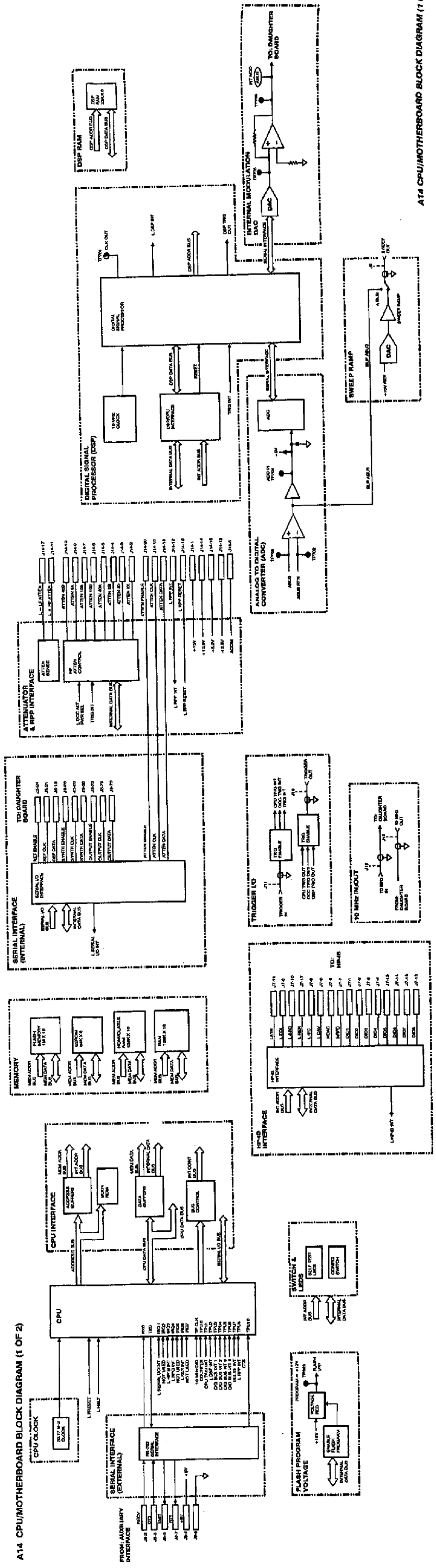

A14 CPU/MOTHERBOARD BLOCK DIAGRAM (1 OF 2)

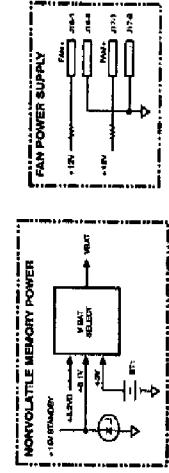
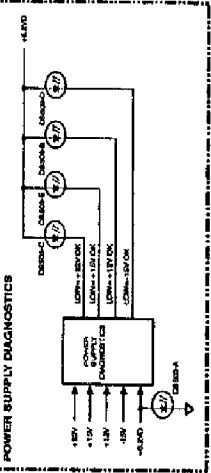
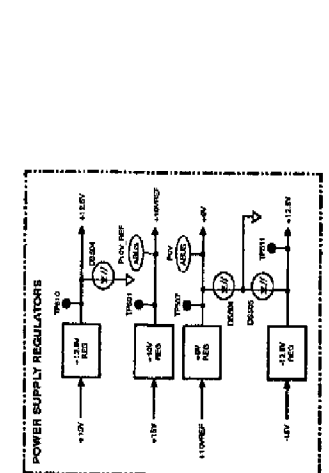
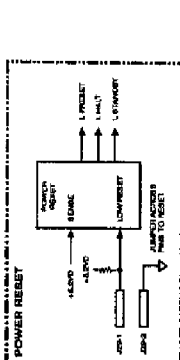
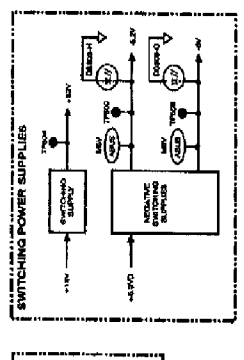
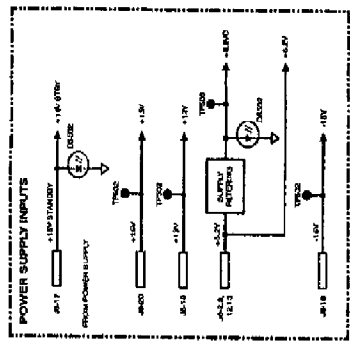
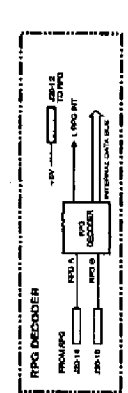
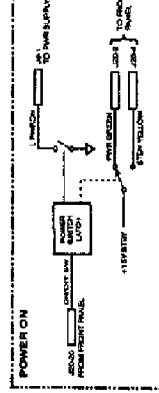
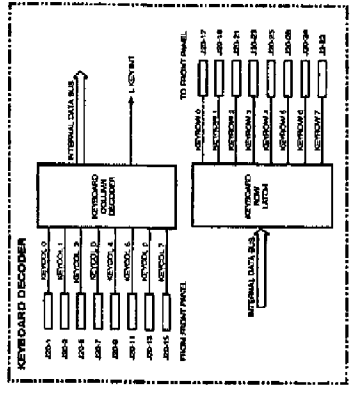
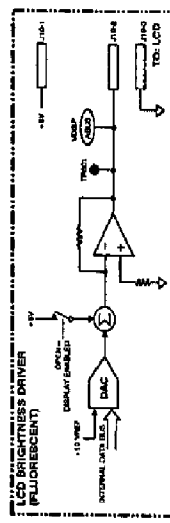
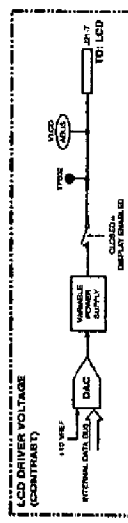
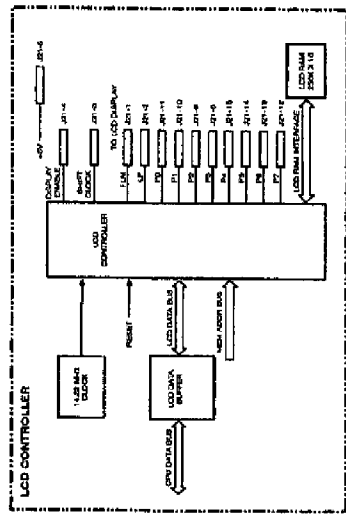

DIGITAL CARD CAGE CONNECTIONS

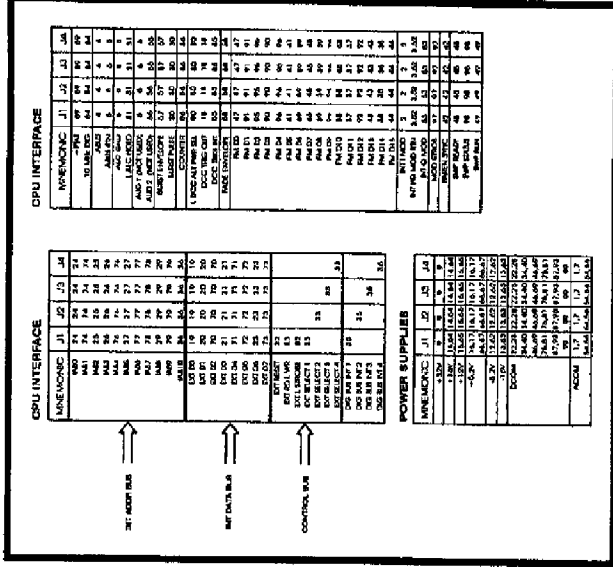

DAUGHTER BOARD CONNECTIONS

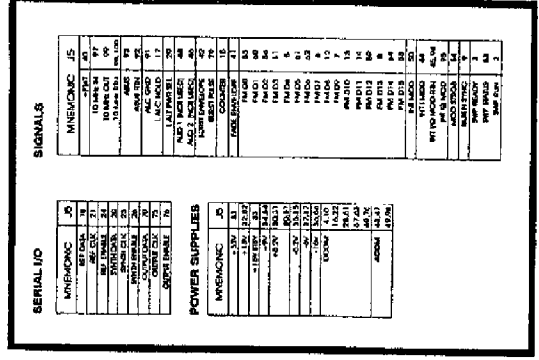

AT1 Attenuator/RPP Block Diagram

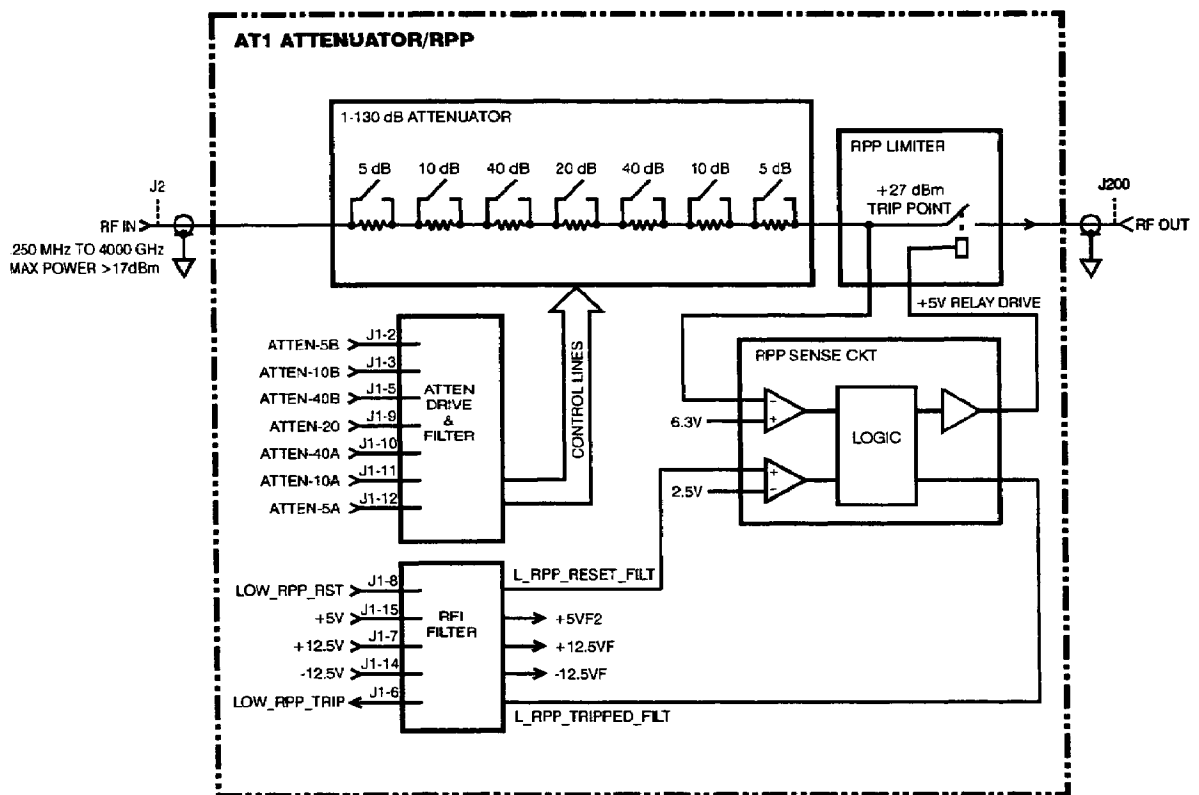

sk7115a

Assembly-Level Troubleshooting with Block Diagrams
AT1 Attenuator/RPP Block Diagram

A7 BASEBAND GENERATOR BLOCK DIAGRAM (OPTIONS UN3 & UN4)

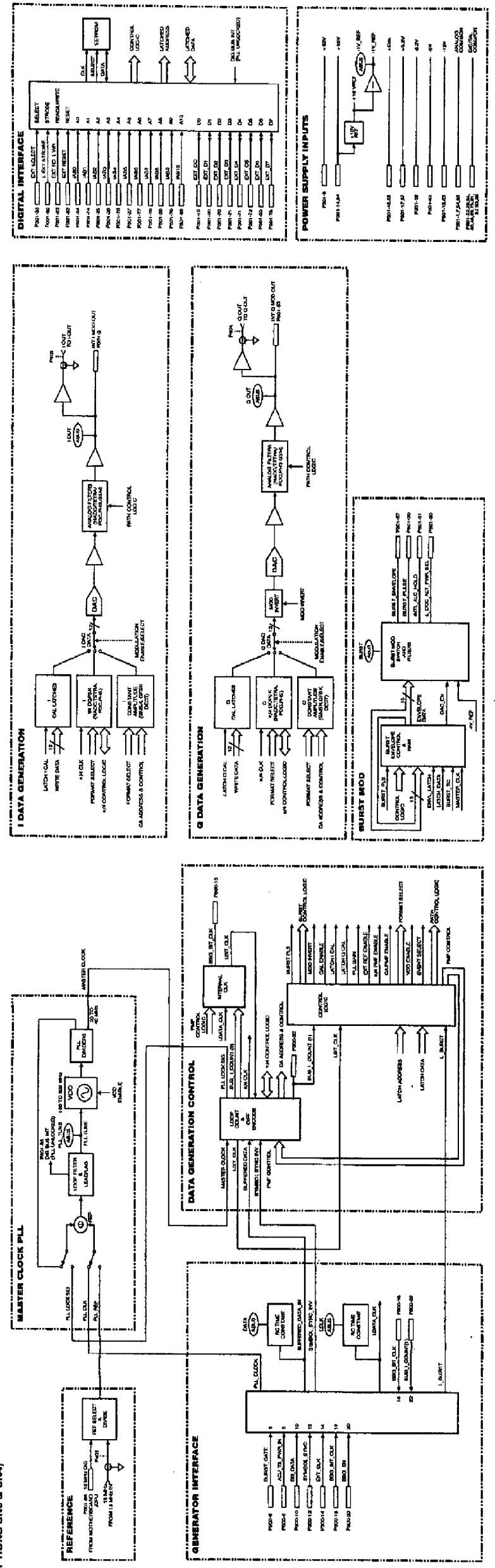

A8 Data Generator Board Block Diagram (Options UN3 & UN4)

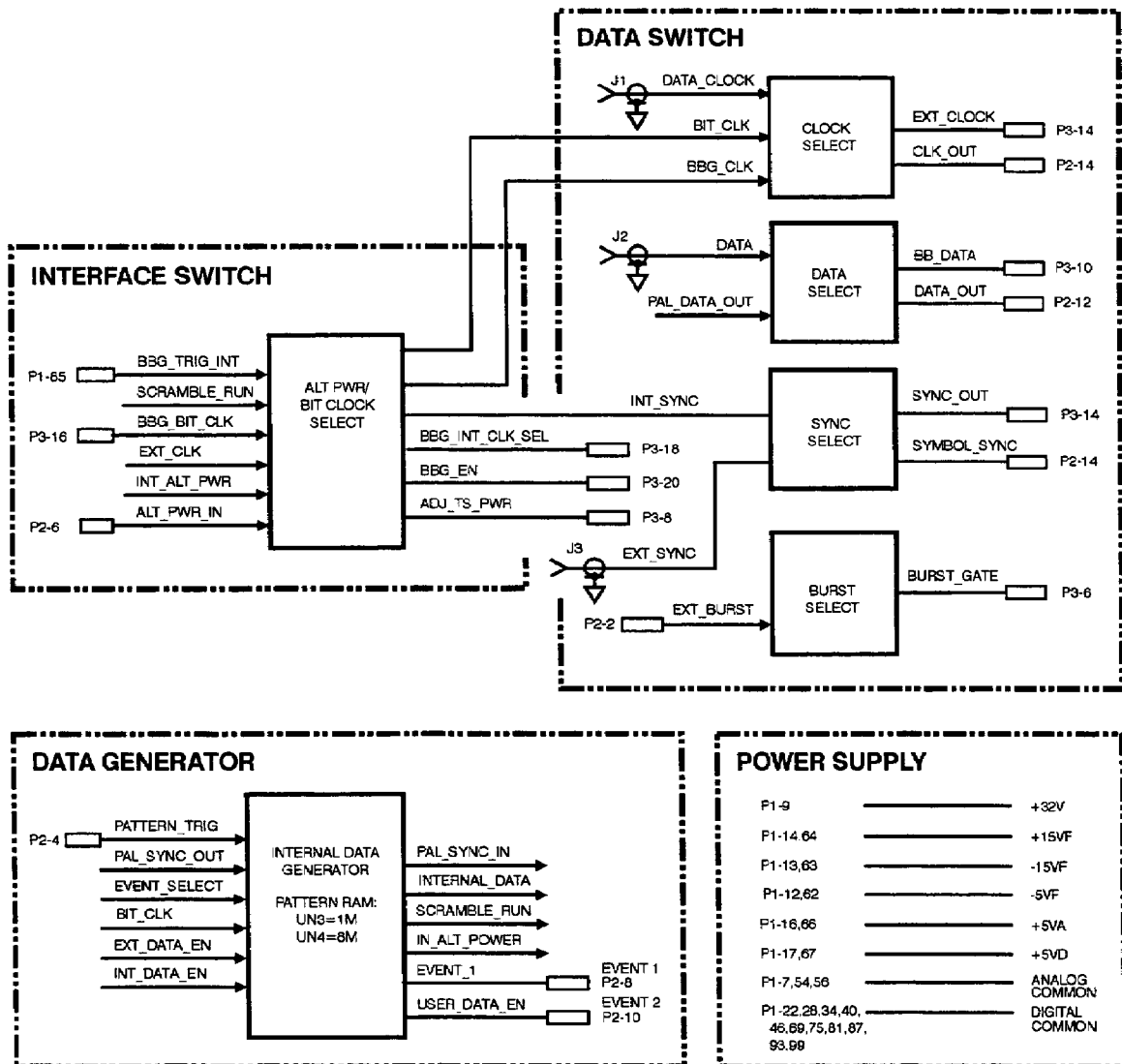

sk7119a

Assembly-Level Troubleshooting with Block Diagrams
A8 Data Generator Board Block Diagram (Options UN3 & UN4)

POWER SUPPLY & GROUND INTERCONNECTS (1 OF 2)

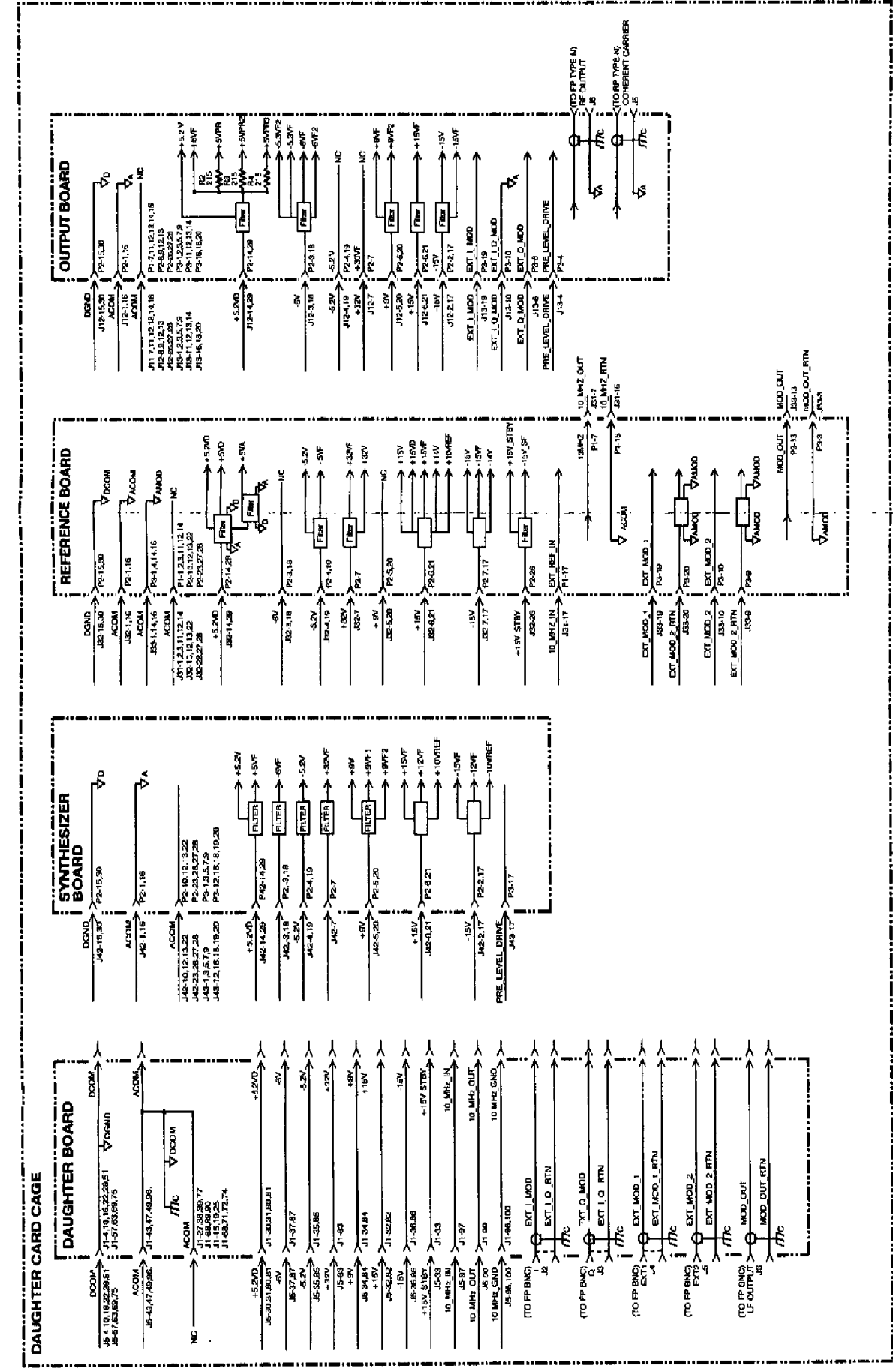
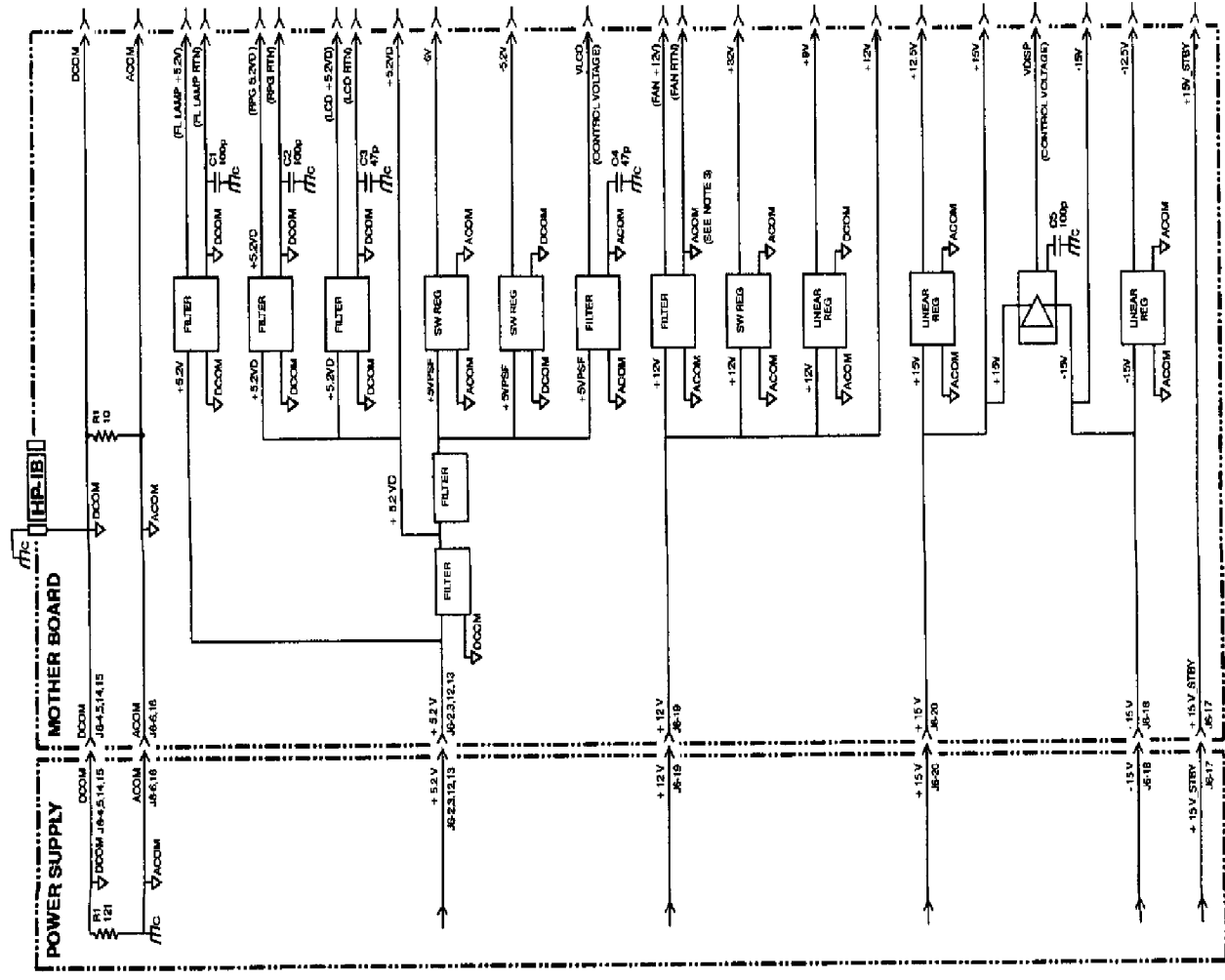

POWER SUPPLY & GROUND INTERCONNECTS (2 OF 2)

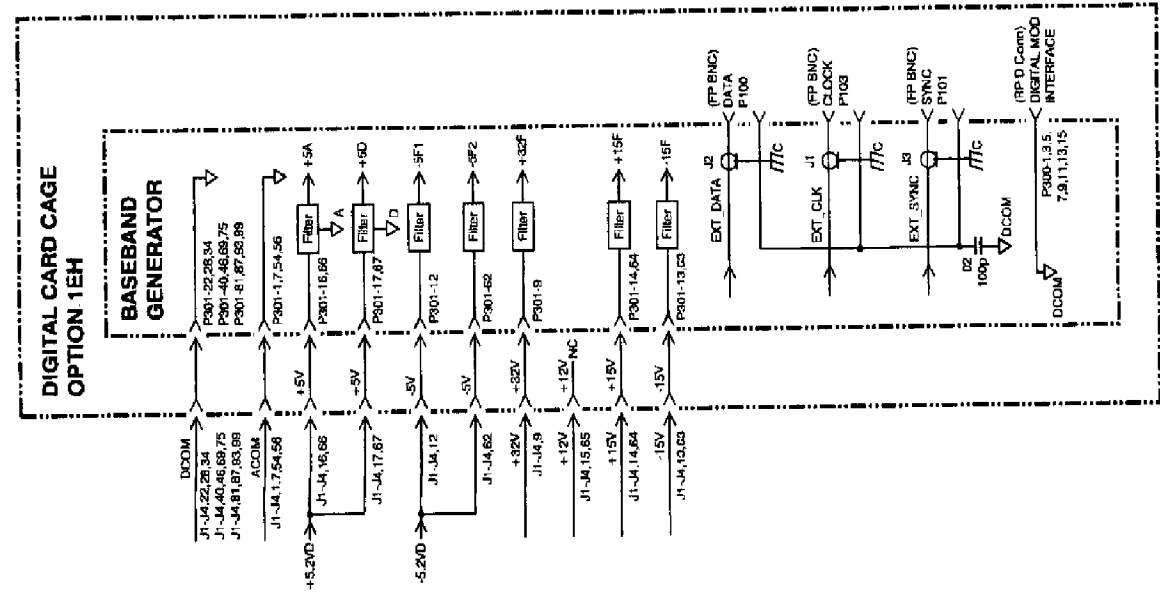

MODULATION AND SIGNAL INTERCONNECTS (2 of 2)

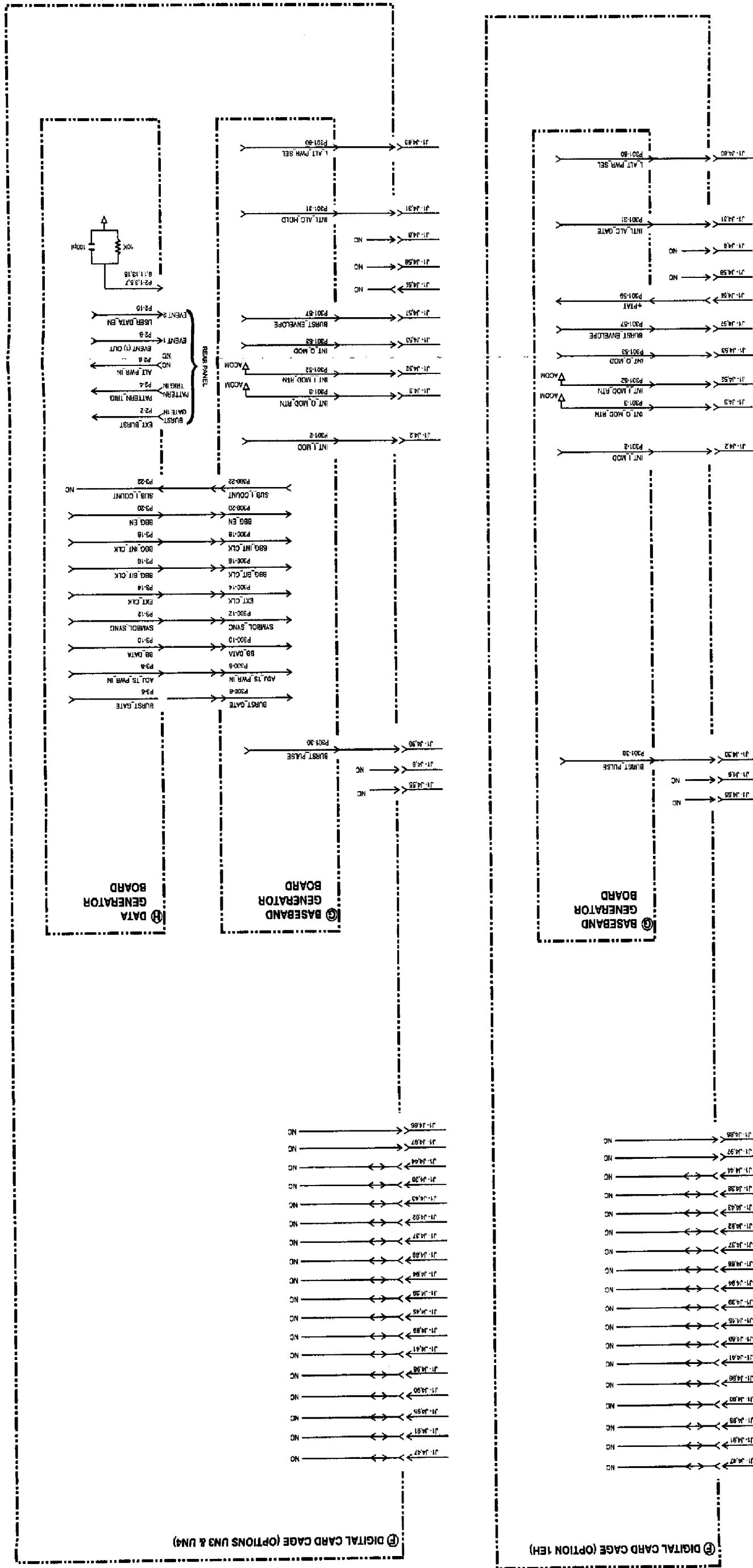

MODULATION AND SIGNAL INTERCONNECTS (2 of 2)

3 Replaceable Parts

This chapter provides important ordering information and lists the part numbers for the various replaceable parts, kits, and accessories available for your signal generator. This chapter is also useful for locating and identifying assemblies and cables.

Ordering Information

To order a part listed in the replaceable parts lists:

1. Determine the part number.
2. Determine the quantity required.
3. Mail this information to the nearest Hewlett-Packard office or, in the U.S., call the hotline number listed in the following section.

To order a part *not* listed in the replaceable parts lists:

1. Note the instrument model number.
2. Note the serial number and options, if any (see rear panel).
3. Describe the part.
4. Describe the function of the part.
5. Determine the quantity required.
6. Mail this information to the nearest Hewlett-Packard office or, in the U.S., call the hotline number listed in the following section.

Call (800) 227-8164 to Order Parts Fast (U.S. Only)

When you have gathered the information required to place an order, contact Hewlett-Packard's direct ordering team by calling the toll-free hotline number shown above. Orders may be placed Monday through Friday, 6 AM to 5 PM (Pacific Standard Time).

The parts specialists have direct on-line access to replacement parts inventory corresponding to the replaceable parts lists in this manual. Four day delivery time is standard; there is a charge for hotline one-day delivery.

This information applies to the United States only. Outside the United States, you must contact the nearest HP sales and service office. (Refer to Table 3-1.)

Table 3-1. Hewlett-Packard Sales and Service Offices

US FIELD OPERATIONS			
<p>Headquarters Hewlett-Packard Company 19320 Pruneridge Avenue Cupertino, CA 95014, USA (800) 752-0900</p> <p>Atlanta Annex Hewlett-Packard Co. 2124 Barrett Park Drive Kennesaw, GA 30144 (404) 648-0000</p>	<p>California, Northern Hewlett-Packard Co. 301 E. Evelyn Mountain View, CA 94041 (415) 694-2000</p> <p>Illinois Hewlett-Packard Co. 5201 Tollview Drive Rolling Meadows, IL 60008 (708) 255-9800</p>	<p>California, Southern Hewlett-Packard Co. 1421 South Manhattan Ave. Fullerton, CA 92631 (714) 999-6700</p> <p>New Jersey Hewlett-Packard Co. 150 Green Pond Road Rockaway, NJ 07866 (201) 586-5400</p>	<p>Colorado Hewlett-Packard Co. 24 Inverness Place, East Englewood, CO 80112 (303) 649-5512</p> <p>Texas Hewlett-Packard Co. 930 E. Campbell Rd. Richardson, TX 75081 (214) 231-6101</p>
EUROPEAN FIELD OPERATIONS			
<p>Headquarters Hewlett-Packard S.A. 150, Route du Nant-d' Avril 1217 Meyrin 2/Geneva Switzerland (41 22) 780.8111</p>	<p>France Hewlett-Packard France 1 Avenue Du Canada Zone D' Activite De Courtaboeuf F-91947 Les Ulis Cedex France (33 1) 69 82 60 60</p>	<p>Germany Hewlett-Packard GmbH Hewlett-Packard Strasse 61352 Bad Homburg v.d.H Germany (49 6172) 16-0</p>	<p>Great Britain Hewlett-Packard Ltd. Eskdale Road, Winnersh Triangle Wokingham, Berkshire RG41 5DZ England (44 734) 696622</p>
INTERCON FIELD OPERATIONS			
<p>Headquarters Hewlett-Packard Company 3495 Deer Creek Rd. Palo Alto, CA 94304-1316 (415) 857-5027</p> <p>Japan Hewlett-Packard Japan, Ltd. 1-27-15 Yabe, Sagamihara Kanagawa 229, Japan (81 427) 59-1311</p>	<p>Australia Hewlett-Packard Australia Ltd. 31-41 Joseph Street Blackburn, Victoria 3130 (61 3) 895-2895</p> <p>Singapore Hewlett-Packard Singapore (Pte.) Ltd. 150 Beach Road #29-00 Gateway West Singapore 0718 (65) 291-9088</p>	<p>Canada Hewlett-Packard (Canada) Ltd. 17500 South Service Road Trans-Canada Highway Kirkland, Quebec H9J 2X8 Canada (514) 697-4232</p> <p>Taiwan Hewlett-Packard Taiwan 8th Floor, H-P Building 337 Fu Hsing North Road Taipei, Taiwan (886 2) 712-0404</p>	<p>China China Hewlett-Packard Co. 38 Bei San Huan X1 Road Shuang Yu Shu Hai Dian District Beijing, China (86 1) 256-6888</p>

Save Money with Rebuilt-Exchange Assemblies

Under the rebuilt-exchange assembly program, certain factory-repaired and tested assemblies are available on a trade-in basis. These assemblies cost less than a new assembly, and meet all factory specifications required of a new assembly.

The defective assembly must be returned for credit under the terms of the rebuilt-exchange assembly program. Figure 3-1 illustrates the assembly exchange procedure in flowchart format.

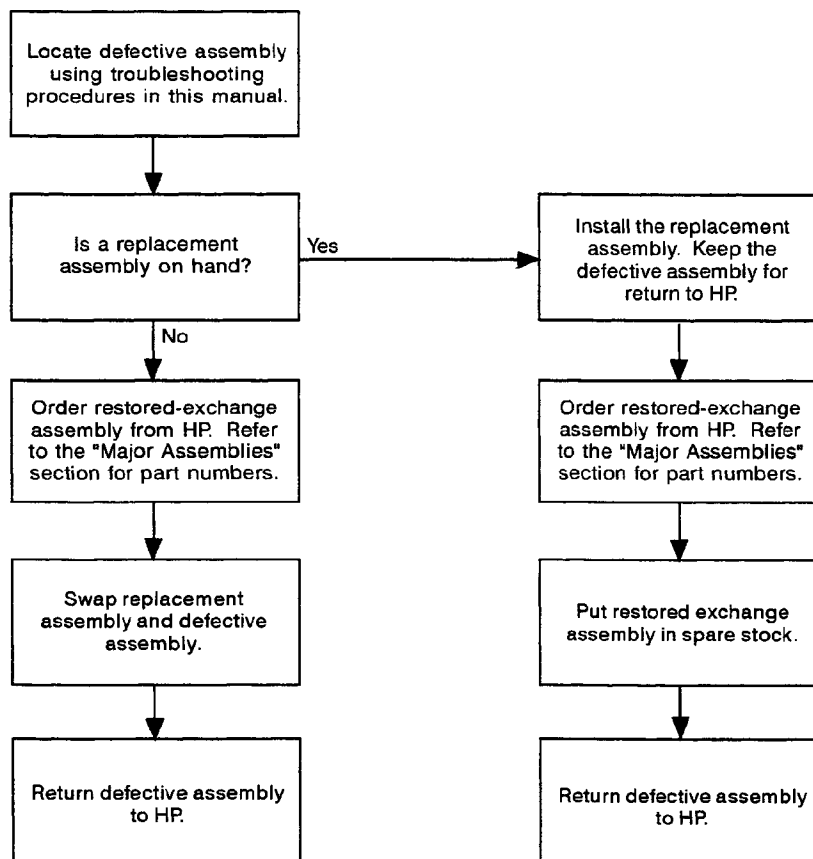

sk770a

Figure 3-1. Assembly Exchange Procedure

Shipping the Defective Assembly Back to Hewlett-Packard

1. When the rebuilt assembly is received, be careful not to damage the box in which it was shipped. You will use that box to return the defective assembly. The box you receive will contain the following:
 - The rebuilt assembly
 - An exchange assembly failure report
 - A return address label
2. Complete the failure report.
3. Place the failure report and the defective assembly in the box. Be sure to remove the enclosed return address label.
4. Seal the box with tape.

If you are inside the United States, stick the preprinted return address label over the label that is already on the box and return box to HP. (HP pays postage on boxes mailed within the United States.)

If you are outside the USA, do not use the return address label; instead, address box to the nearest HP sales and service office. (Refer to Table 3-1.)

Abbreviations Used in Part Descriptions

This section defines the reference designators, abbreviations, and option numbers that are used in the part descriptions throughout this chapter.

Reference Designations

Reference Designator	Definition
A	assembly
AT	attenuator
B	fan
DS	lamp
J	electrical connector; jack
P	electrical connector; plug
W	cable; transmission path; wire

Abbreviations

Abbreviation	Definition
Assy	assembly
Bd	board
BC	beryllium
BN	buttonhead (screws)
CPU	central processing unit
CW	conical washer (screws)
CY	copper
D	diameter
ESD	electrostatic discharge
EXT	external
FL	flathead (screws)
Ft	feet
Hex	hexagonal
HP-IB	Hewlett-Packard interface bus
HX	hexagonal recess (screws)
I	in-phase
ID	inside diameter
L	length
LF	low frequency

Abbreviations

Abbreviation	Definition
M	meters or metric hardware
OD	outside diameter
PC	patch lock (screws) or printed circuit
PN	panhead (screws)
Q	quadrature
Qty	quantity
REF	reference
RF	radio frequency
RFI	radio frequency interference
RPP	reverse power protection
SH	socket head cap (screws)
SMA	subminiature type-A
SMB	subminiature type-B
TX	TORX recess (screws)
V	volt

Options

Options	Definition
1E5	Precision Frequency Reference
1EH	Baseband Generator
1EM	Rear Panel Connections
UN3	Baseband Generator - 1 Meg
UN4	Baseband Generator - 8 Meg

Replaceable Parts
Major Assemblies

Major Assemblies

Top View

Reference Designator	HP Part Number	Qty	Description
A4	0950-2929	1	Assy-Power Supply
A7	E4400-60005	1	Bd Assy-Baseband Generator (Option 1EH)
A7	E4400-69005		Exchange Bd Assy-Baseband Generator (Option 1EH)
A7	E4400-60048	1	Bd Assy-Baseband Generator (Options UN3, UN4)
A7	E4400-69048		Exchange Bd Assy-Baseband Generator (Options UN3, UN4)
A8	E4400-60043	1	Bd Assy-Data Generator, 1 Meg (Option UN3)
A8	E4400-69043		Exchange Bd Assy-Data Generator, 1 Meg (Option UN3)
A8	E4400-60057	1	Bd Assy-Data Generator, 8 Meg (Option UN4)
A8	E4400-69057		Exchange Bd Assy-Data Generator, 8 Meg (Option UN4)
A14	E4400-60001	1	Bd Assy-CPU/Mother
A14	E4400-69001		Exchange Bd Assy-CPU/Mother
A14BT1	1420-0338	1	Battery-Lithium
AT1	E4400-60007	1	Assy-Electronic Attenuator/RPP
AT1	E4400-69007		Exchange Assy-Electronic Attenuator/RPP
B1	3160-1040	1	Assy-Fan, Small
B2	E4400-60062	1	Kit-Fan, Large (includes 2 foam strips)

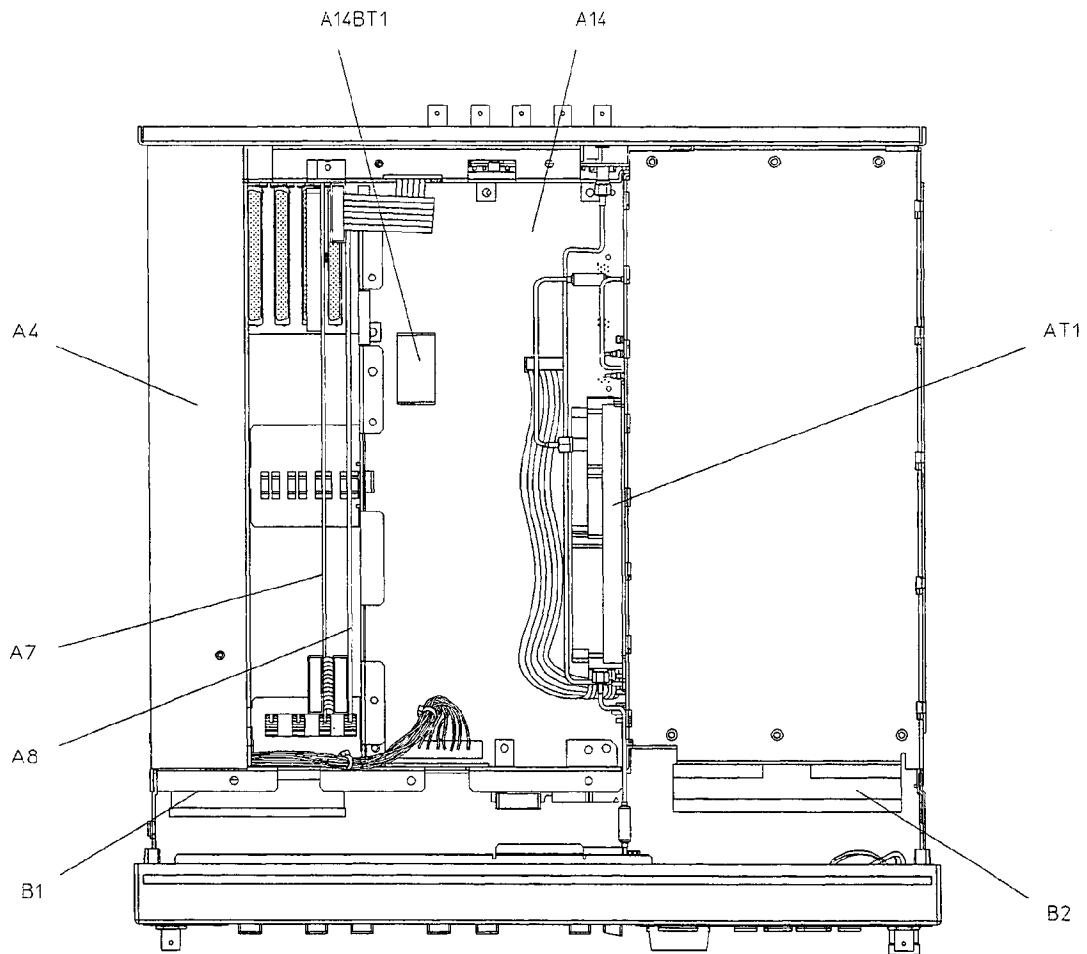

sk7142a

Top View

Replaceable Parts
Major Assemblies

Right Side View

Reference Designator	HP Part Number	Qty	Description
A9	E4400-60003	1	Bd Assy-Output
A9	E4400-69003		Exchange Bd Assy-Output
A11	E4400-60010	1	Bd Assy-Reference, TCXO
A11	E4400-69010		Exchange Bd Assy-Reference, TCXO
A11	E4400-60009	1	Bd Assy-Reference, OCXO (Option 1E5)
A11	E4400-69009		Exchange Bd Assy-Reference, OCXO (Option 1E5)
A12	E4400-60002	1	Bd Assy-Synthesizer/Doubler
A12	E4400-69002		Exchange Bd Assy-Synthesizer/Doubler
A15	E4400-60011	1	Bd Assy-Daughter

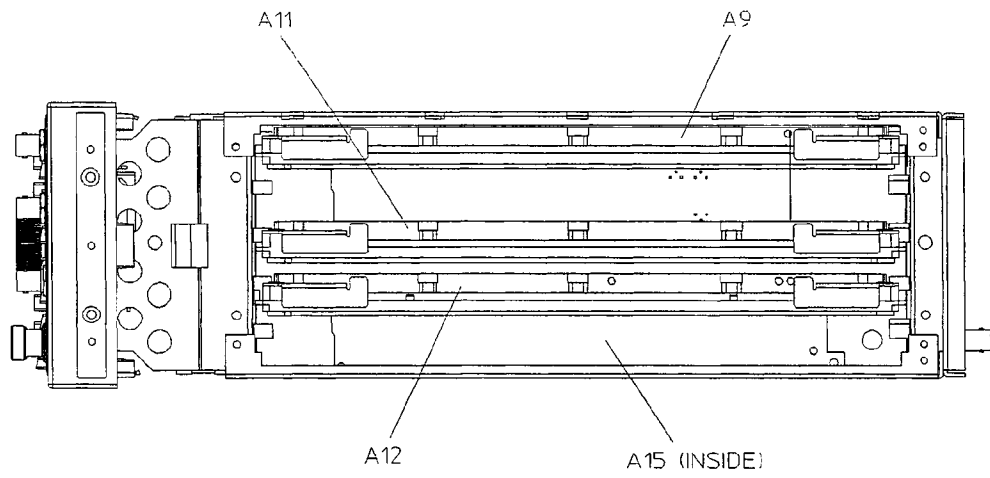

sk714c

Right Side View

Replaceable Parts
Major Assemblies

Disassembled Front Panel View

Reference Designator	HP Part Number	Qty	Description
A1	E4400-60004	1	Bd Assy- Front Panel
A2	1990-1910	1	Assy-Display
A2DS1	1513-5204	1	Lamp-Fluorescent
A3	0950-3093	1	Assy-Inverter

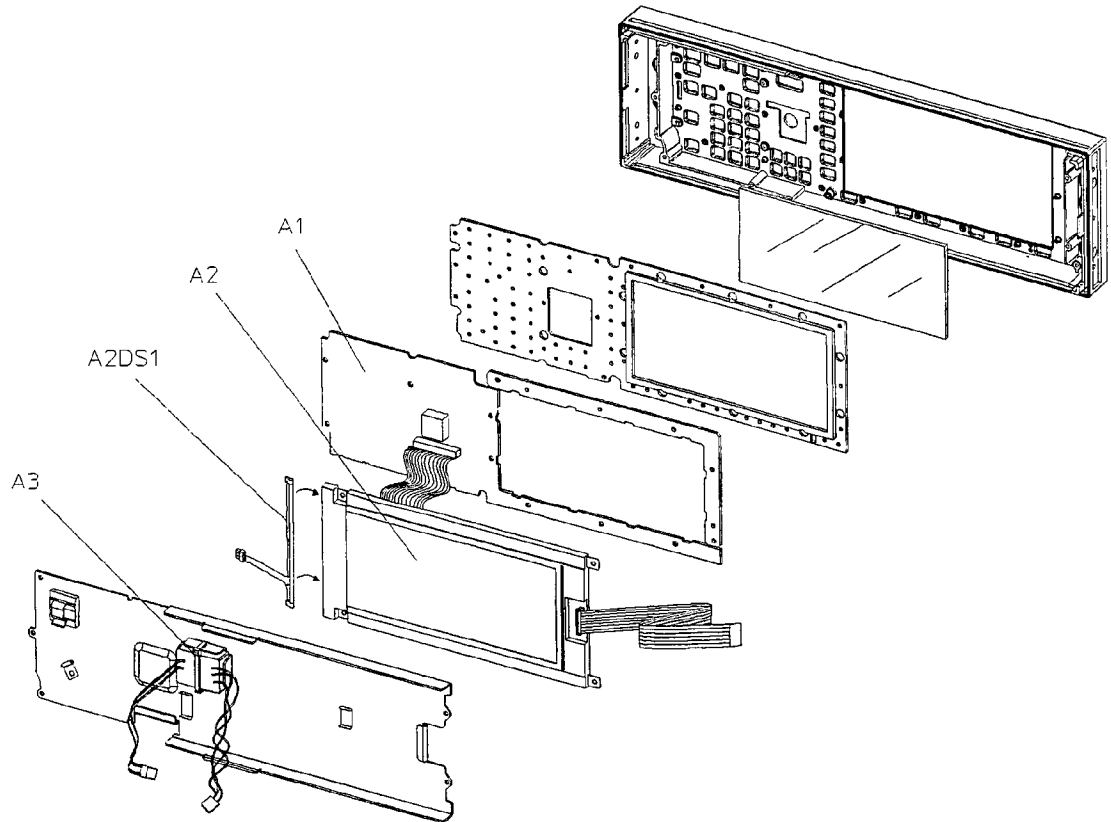

sk731a

Disassembled Front Panel View

Replaceable Parts
Major Assemblies

Inside Rear Panel View

Reference Designator	HP Part Number	Qty	Description
A16	5063-9711	1	Assy-Line Module
A17	E4400-60044	1	Bd Assy-Rear Panel Interface (Options 1EH, UN3, UN4)
A17	E4400-60045	1	Bd Assy-Rear Panel Interface (Options 1EH/1EM, UN3/1EM, UN4/1EM)

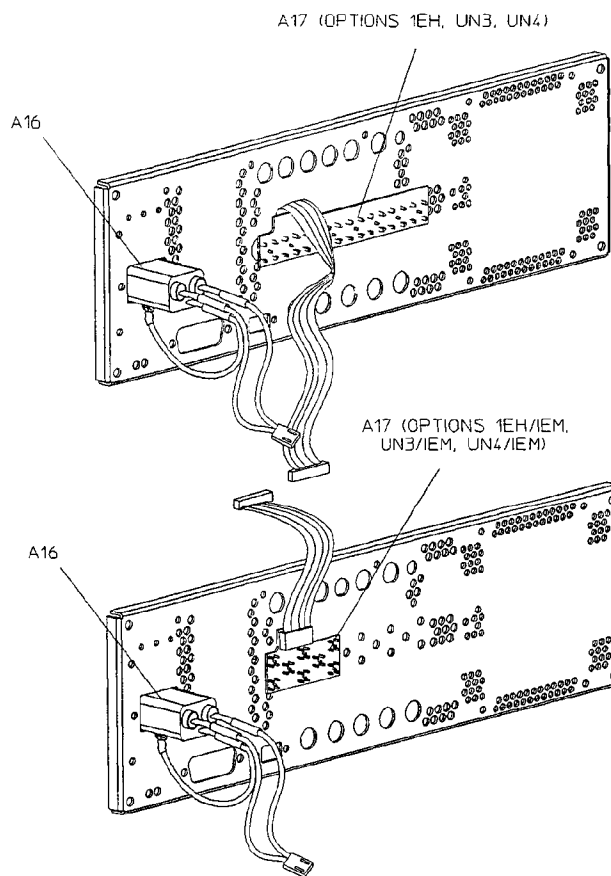

sk7141a

Inside Rear Panel View

Replaceable Parts
Cables

Cables

Top View (standard)

Reference Designator	HP Part Number	Qty	Description
A4W1 ¹	(part of A4)	1	Power Supply (A4) to CPU/Motherboard (A14J6)
A16W1 ¹	(part of A16)	1	Line Module (A16) to Power Supply (A4J1)
A16W2 ¹	(part of A16)	1	Line Module (A16) to Chassis Ground Post on Rear Panel
W1	8120-6758	1	I IN to Daughterboard (A15J2)
W2	8120-6758	1	Q IN to Daughterboard (A15J3)
W6	8120-6758	1	EXT 1 to Daughterboard (A15J4)
W7	8120-6758	1	EXT 2 to Daughterboard (A15J5)
W8	8120-6758	1	LF OUTPUT to Daughterboard (A15J6)
W9	E4400-20018	1	RF OUTPUT to Electronic Attenuator/RPP (AT1)
W11	E4400-60059	1	Output Board (A9) to Synthesizer/Doubler Board (A12) (includes cable retainer and ring)
W12	E4400-60060	1	Output Board (A9) to COHERENT CARRIER (includes cable retainer and ring)
W13	8120-6837	1	Electronic Attenuator/RPP (AT1) to CPU/Motherboard (A14J14)
W14	E4400-60061	1	Electronic Attenuator/RPP (AT1) to Output Board (A9) (includes cable retainer and ring)

1. This cable is not replaceable by itself. You must order the corresponding assembly.

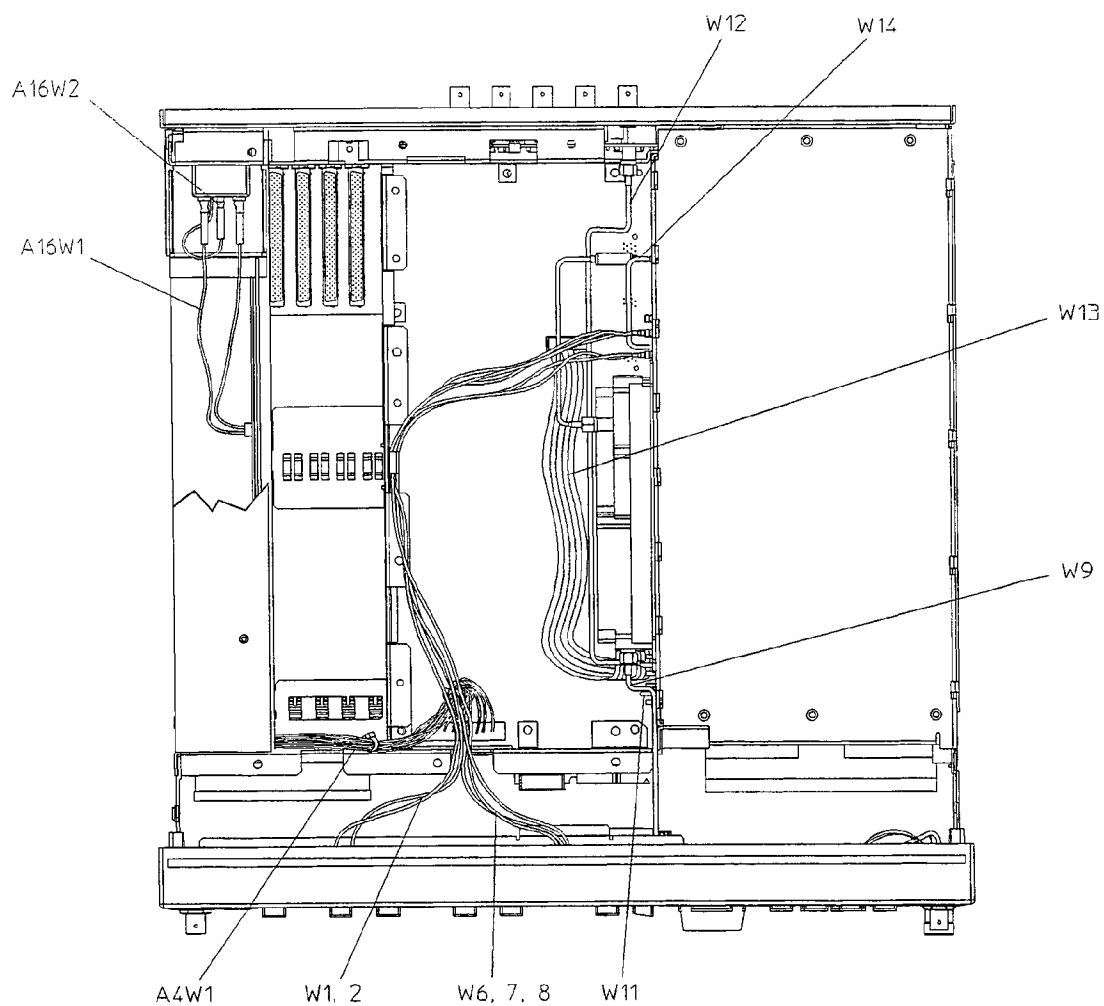

sk7125a

Top View (standard)

Replaceable Parts
Cables

Top View (Option 1EH)

Reference Designator	HP Part Number	Qty	Description
A4W1 ¹	(part of A4)	1	Power Supply (A4) to CPU/Motherboard (A14J6)
A16W1 ¹	(part of A16)	1	Line Module (A16) to Power Supply (A4J1)
A16W2 ¹	(part of A16)	1	Line Module (A16) to Chassis Ground Post on Rear Panel
A17W1 ¹	(part of A17)	1	Rear Panel Interface Board (A17) to Baseband Generator (A7P300)
W1	8120-6758	1	I IN to Daughterboard (A15J2)
W2	8120-6758	1	Q IN to Daughterboard (A15J3)
W3	8120-5401	1	DATA to Baseband Generator (A7P100)
W4	8120-5401	1	DATA CLOCK to Baseband Generator (A7P103)
W5	8120-5401	1	SYMBOL SYNC to Baseband Generator (A7P101)
W6	8120-6758	1	EXT 1 to Daughterboard (A15J4)
W7	8120-6758	1	EXT 2 to Daughterboard (A15J5)
W8	8120-6758	1	LF OUTPUT to Daughterboard (A15J6)
W9	E4400-20018	1	RF OUTPUT to Electronic Attenuator/RPP (AT1)
W11	E4400-60059	1	Output Board (A9) to Synthesizer/Doubler Board (A12) (includes cable retainer and ring)
W12	E4400-60060	1	Output Board (A9) to COHERENT CARRIER (includes cable retainer and ring)
W13	8120-6837	1	Electronic Attenuator/RPP (AT1) to CPU/Motherboard (A14J14)
W14	E4400-60061	1	Electronic Attenuator/RPP (AT1) to Output Board (A9) (includes cable retainer and ring)
W15	8120-5055	1	Baseband Generator (A7P403) to 13 MHz
W16	8120-5055	1	Baseband Generator (A7P404) to Q OUT
W17	8120-5055	1	Baseband Generator (A7P405) to I OUT

1. This cable is not replaceable by itself. You must order the corresponding assembly.

Replaceable Parts
Cables

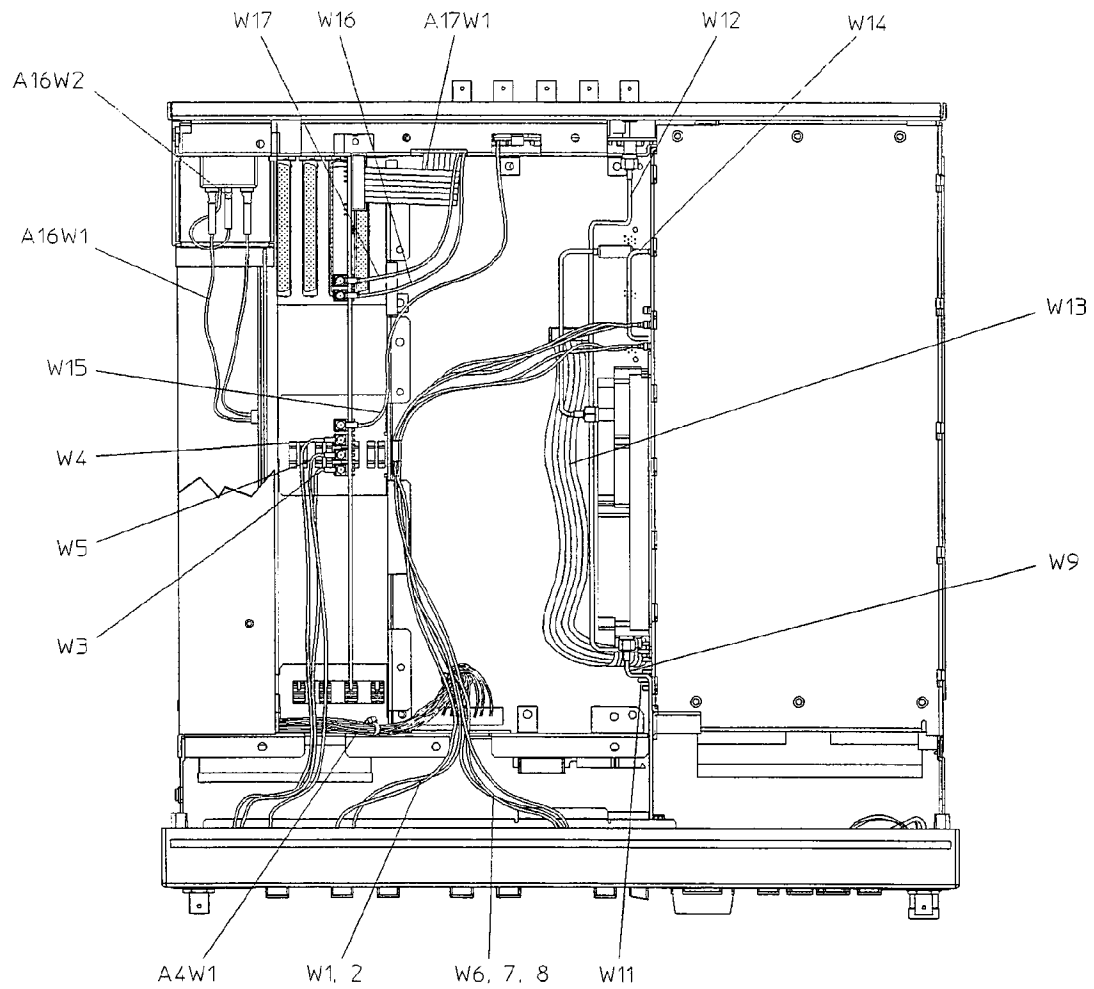

sk716a

Top View (Option 1EH)

Replaceable Parts
Cables

Top View (Options UN3 & UN4)

Reference Designator	HP Part Number	Qty	Description
A4W1 ¹	(part of A4)	1	Power Supply (A4) to CPU/Motherboard (A14J6)
A16W1 ¹	(part of A16)	1	Line Module (A16) to Power Supply (A4J1)
A16W2 ¹	(part of A16)	1	Line Module (A16) to Chassis Ground Post on Rear Panel
A17W1 ¹	(part of A17)	1	Rear Panel Interface Board (A17) to Data Generator (A8P2)
W1	8120-6758	1	I IN to Daughterboard (A15J2)
W2	8120-6758	1	Q IN to Daughterboard (A15J3)
W3	8120-5401	1	DATA to Data Generator (A8J2)
W4	8120-5401	1	DATA CLOCK to Data Generator (A8J1)
W5	8120-5401	1	SYMBOL SYNC to Data Generator (A8J3)
W6	8120-6758	1	EXT 1 to Daughterboard (A15J4)
W7	8120-6758	1	EXT 2 to Daughterboard (A15J5)
W8	8120-6758	1	LF OUTPUT to Daughterboard (A15J6)
W9	E4400-20018	1	RF OUTPUT to Electronic Attenuator/RPP (AT1)
W11	E4400-60059	1	Output Board (A9) to Synthesizer/Doubler Board (A12) (includes cable retainer and ring)
W12	E4400-60060	1	Output Board (A9) to COHERENT CARRIER (includes cable retainer and ring)
W13	8120-6837	1	Electronic Attenuator/RPP (AT1) to CPU/Motherboard (A14J14)
W14	E4400-60061	1	Electronic Attenuator/RPP (AT1) to Output Board (A9) (includes cable retainer and ring)
W15	8120-5055	1	Baseband Generator (A7P403) to 13 MHz
W16	8120-5055	1	Baseband Generator (A7P404) to Q OUT
W17	8120-5055	1	Baseband Generator (A7P405) to I OUT
W19	8120-8349	1	Baseband Generator (A7P300) to Data Generator (A8P3)

1. This cable is not replaceable by itself. You must order the corresponding assembly.

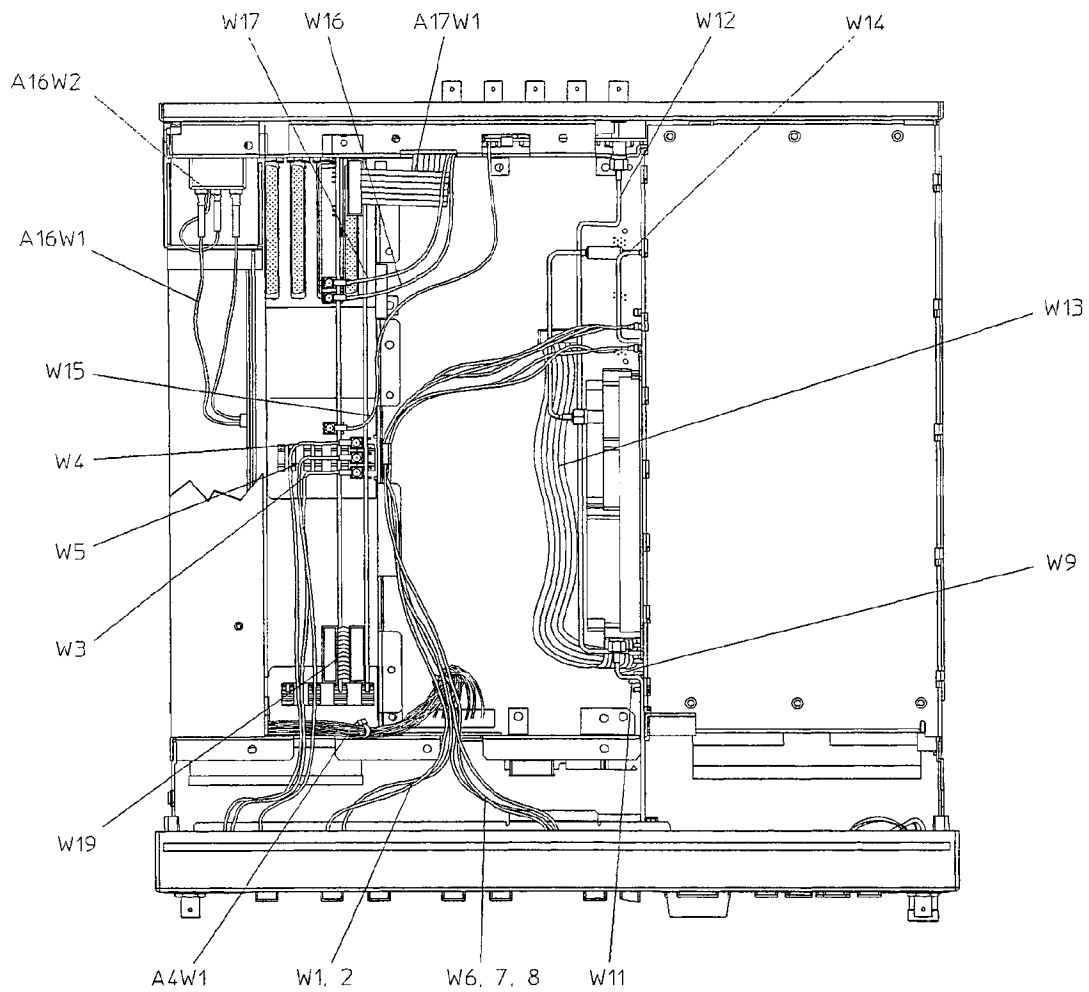

sk7123a

Top View (Options UN3 & UN4)

Replaceable Parts
Cables

Top View (Option 1EM)

Reference Designator	HP Part Number	Qty	Description
A4W1 ¹	(part of A4)	1	Power Supply (A4) to CPU/Motherboard (A14J6)
A16W1 ¹	(part of A16)	1	Line Module (A16) to Power Supply (A4J1)
A16W2 ¹	(part of A16)	1	Line Module (A16) to Chassis Ground Post on Rear Panel
W1	8120-6839	1	I IN to Daughterboard (A15J2)
W2	8120-6839	1	Q IN to Daughterboard (A15J3)
W6	8120-6839	1	EXT 1 to Daughterboard (A15J4)
W7	8120-6839	1	EXT 2 to Daughterboard (A15J5)
W8	8120-6839	1	LF OUTPUT to Daughterboard (A15J6)
W9	E4400-20025	1	RF OUTPUT to Electronic Attenuator/RPP (AT1)
W11	E4400-60059	1	Output Board (A9) to Synthesizer/Doubler Board (A12) (includes cable retainer and ring)
W12	E4400-60060	1	Output Board (A9) to COHERENT CARRIER (includes cable retainer and ring)
W13	8120-6837	1	Electronic Attenuator/RPP (AT1) to CPU/Motherboard (A14J14)
W14	E4400-60061	1	Electronic Attenuator/RPP (AT1) to Output Board (A9) (includes cable retainer and ring)

1. This cable is not replaceable by itself. You must order the corresponding assembly.

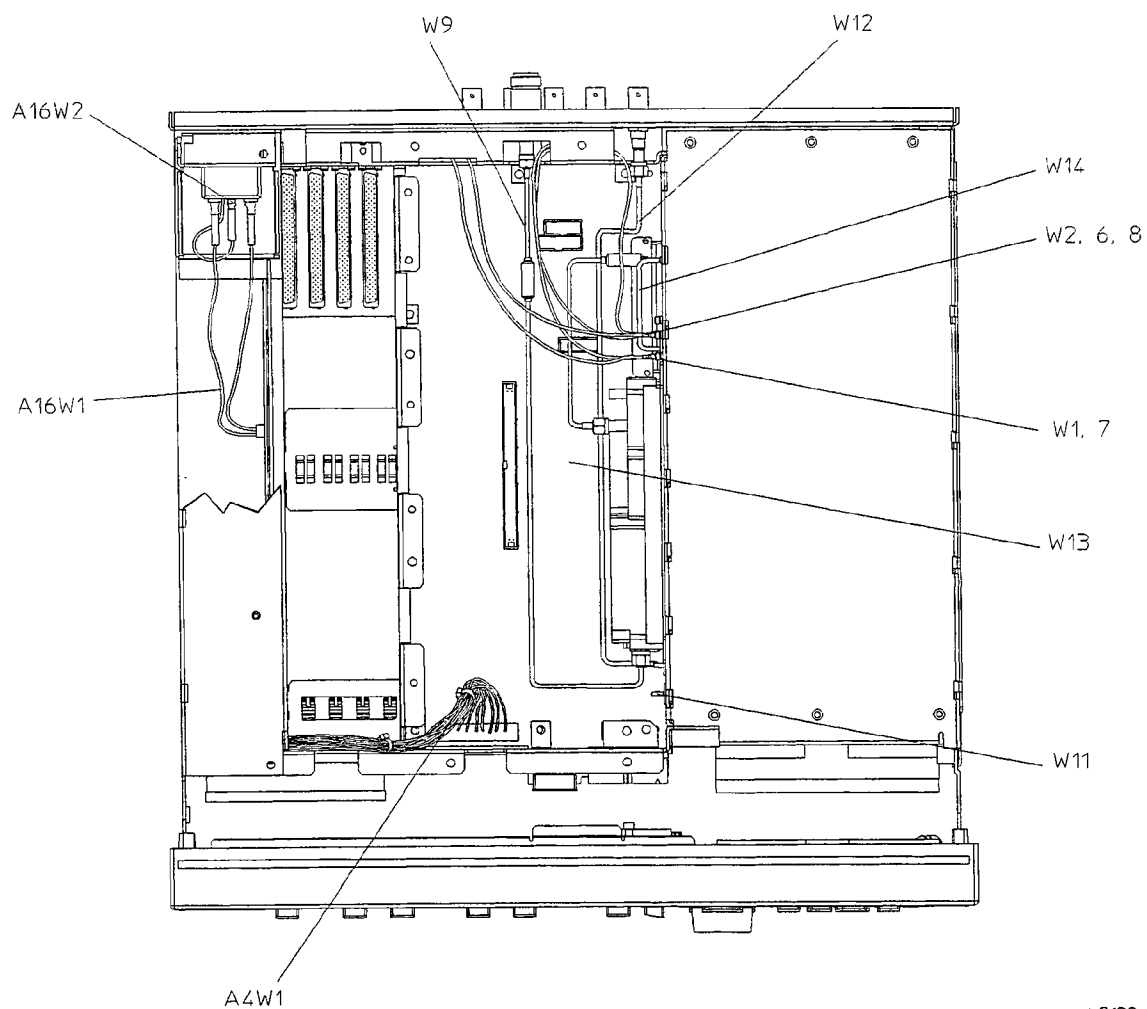

sk7122a

Top View (Option 1EM)

Replaceable Parts
Cables

Top View (Option 1EH/1EM)

Reference Designator	HP Part Number	Qty	Description
A4W1 ¹	(part of A4)	1	Power Supply (A4) to CPU/Motherboard (A14J6)
A16W1 ¹	(part of A16)	1	Line Module (A16) to Power Supply (A4J1)
A16W2 ¹	(part of A16)	1	Line Module (A16) to Chassis Ground Post on Rear Panel
A17W1 ¹	(part of A17)	1	Rear Panel Interface Board (A17) to Baseband Generator (A7P300)
W1	8120-6839	1	I IN to Daughterboard (A15J2)
W2	8120-6839	1	Q IN to Daughterboard (A15J3)
W3	8120-5143	1	DATA to Baseband Generator (A7P100)
W4	8120-5143	1	DATA CLOCK to Baseband Generator (A7P103)
W5	8120-5143	1	SYMBOL SYNC to Baseband Generator (A7P101)
W6	8120-6839	1	EXT 1 to Daughterboard (A15J4)
W7	8120-6839	1	EXT 2 to Daughterboard (A15J5)
W8	8120-6839	1	LF OUTPUT to Daughterboard (A15J6)
W9	E4400-20025	1	RF OUTPUT to Electronic Attenuator/RPP (AT1)
W11	E4400-60059	1	Output Board (A9) to Synthesizer/Doubler Board (A12) (includes cable retainer and ring)
W12	E4400-60060	1	Output Board (A9) to COHERENT CARRIER (includes cable retainer and ring)
W13	8120-6837	1	Electronic Attenuator/RPP (AT1) to CPU/Motherboard (A14J14)
W14	E4400-60061	1	Electronic Attenuator/RPP (AT1) to Output Board (A9) (includes cable retainer and ring)
W15	8120-5143	1	Baseband Generator (A7P403) to 13 MHz
W16	8120-5143	1	Baseband Generator (A7P404) to Q OUT
W17	8120-5143	1	Baseband Generator (A7P405) to I OUT

1. This cable is not replaceable by itself. You must order the corresponding assembly.

Replaceable Parts
Cables

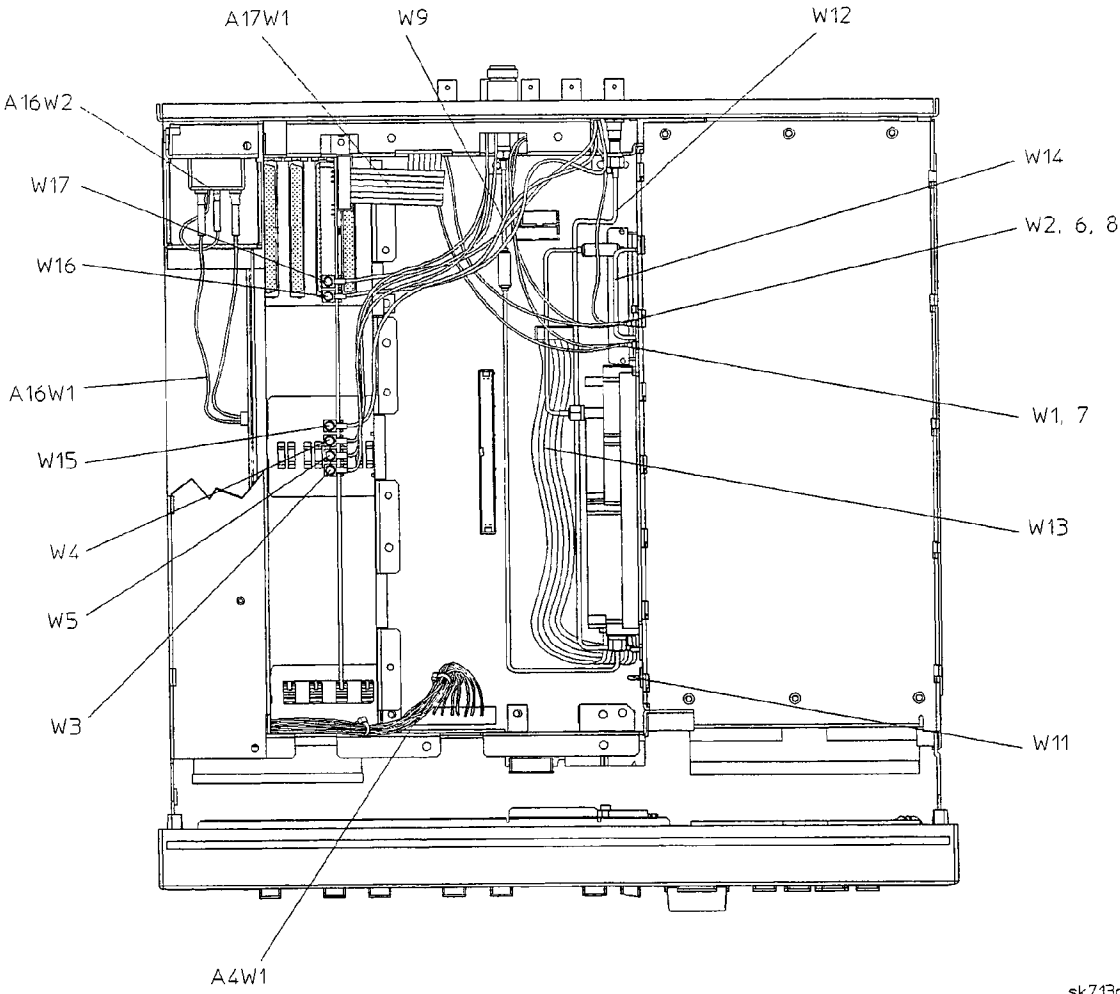

sk713a

Top View (Option 1EH/1EM)

Replaceable Parts
Cables

Top View (Options UN3/1EM & UN4/1EM)

Reference Designator	HP Part Number	Qty	Description
A4W1 ¹	(part of A4)	1	Power Supply (A4) to CPU/Motherboard (A14J6)
A16W1 ¹	(part of A16)	1	Line Module (A16) to Power Supply (A4J1)
A16W2 ¹	(part of A16)	1	Line Module (A16) to Chassis Ground Post on Rear Panel
A17W1 ¹	(part of A17)	1	Rear Panel Interface Board (A17) to Data Generator (A8P2)
W1	8120-6839	1	I IN to Daughterboard (A15J2)
W2	8120-6839	1	Q IN to Daughterboard (A15J3)
W3	8120-5143	1	DATA to Data Generator (A8J2)
W4	8120-5143	1	DATA CLOCK to Data Generator (A8J1)
W5	8120-5143	1	SYMBOL SYNC to Data Generator (A8J3)
W6	8120-6839	1	EXT 1 to Daughterboard (A15J4)
W7	8120-6839	1	EXT 2 to Daughterboard (A15J5)
W8	8120-6839	1	LF OUTPUT to Daughterboard (A15J6)
W9	E4400-20025	1	RF OUTPUT to Electronic Attenuator/RPP (AT1)
W11	E4400-60059	1	Output Board (A9) to Synthesizer/Doubler Board (A12) (includes cable retainer and ring)
W12	E4400-60060	1	Output Board (A9) to COHERENT CARRIER (includes cable retainer and ring)
W13	8120-6837	1	Electronic Attenuator/RPP (AT1) to CPU/Motherboard (A14J14)
W14	E4400-60061	1	Electronic Attenuator/RPP (AT1) to Output Board (A9) (includes cable retainer and ring)
W15	8120-5143	1	Baseband Generator (A7P403) to 13 MHz
W16	8120-5143	1	Baseband Generator (A7P404) to Q OUT
W17	8120-5143	1	Baseband Generator (A7P405) to I OUT
W19	8120-8349	1	Baseband Generator (A7P300) to Data Generator (A8P3)

1. This cable is not replaceable by itself. You must order the corresponding assembly.

Replaceable Parts
Cables

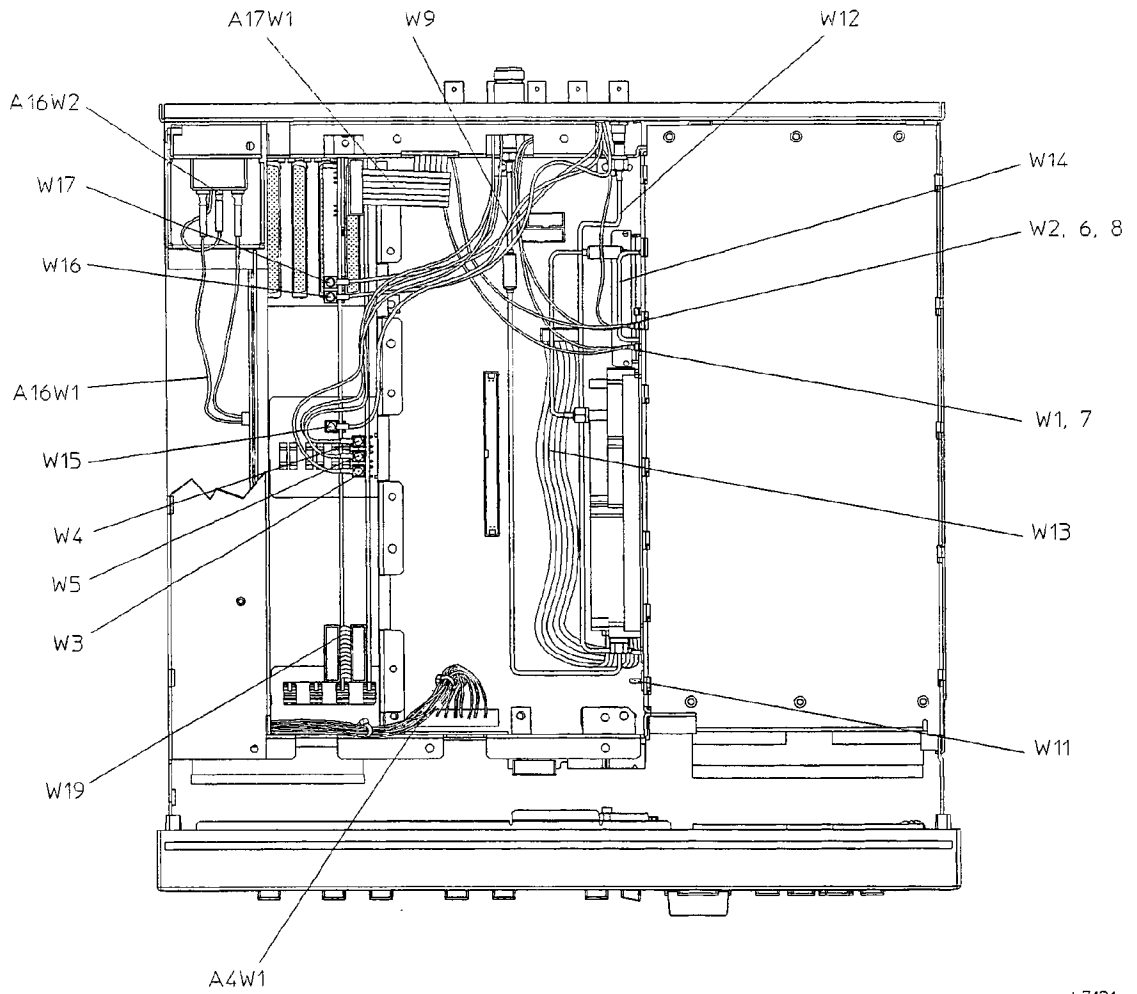

sk7121a

Top View (Options UN3/1EM & UN4/1EM)

Replaceable Parts
Cables

Inside Front Panel View

Reference Designator	HP Part Number	Qty	Description
A1W1 ¹	(part of A1)	1	Front Panel Board (A1) to CPU/Motherboard (A14J20)
A2DS1W1 ¹	(part of A2DS1)	1	Florescent Lamp (A2DS1) to A3W2
A3W1 ¹	(part of A3)	1	Inverter (A3) to CPU/Motherboard (A14J19)
A3W2 ¹	(part of A3)	1	Inverter (A3) to A2DS1W1
B1W1 ¹	(part of B1)	1	Small Fan (B1) to CPU/Motherboard (A14J16)
B2W1 ¹	(part of B2)	1	Large Fan (B2) to CPU/Motherboard (A14J17)
W1	8120-6758	1	I IN to Daughterboard (A15J2)
W2	8120-6758	1	Q IN to Daughterboard (A15J3)
W3	8120-5401	1	DATA to Baseband Generator (A7P100) (Options 1EH, UN3, UN4)
W4	8120-5401	1	DATA CLOCK to Baseband Generator (A7P103) (Options 1EH, UN3, UN4)
W5	8120-5401	1	SYMBOL SYNC to Baseband Generator (A7P101) (Options 1EH, UN3, UN4)
W6	8120-6758	1	EXT 1 to Daughterboard (A15J4)
W7	8120-6758	1	EXT 2 to Daughterboard (A15J5)
W8	8120-6758	1	LF OUTPUT to Daughterboard (A15J6)
W9	E4400-20018	1	RF OUTPUT to Electronic Attenuator/RPP (AT1)
W10	8120-6759	1	Display (A2) to CPU/Motherboard (A14J21)

1. This cable is not replaceable by itself. You must order the corresponding assembly.

NOTE: W1 through W9 are not present on the front panel with Option 1EM.

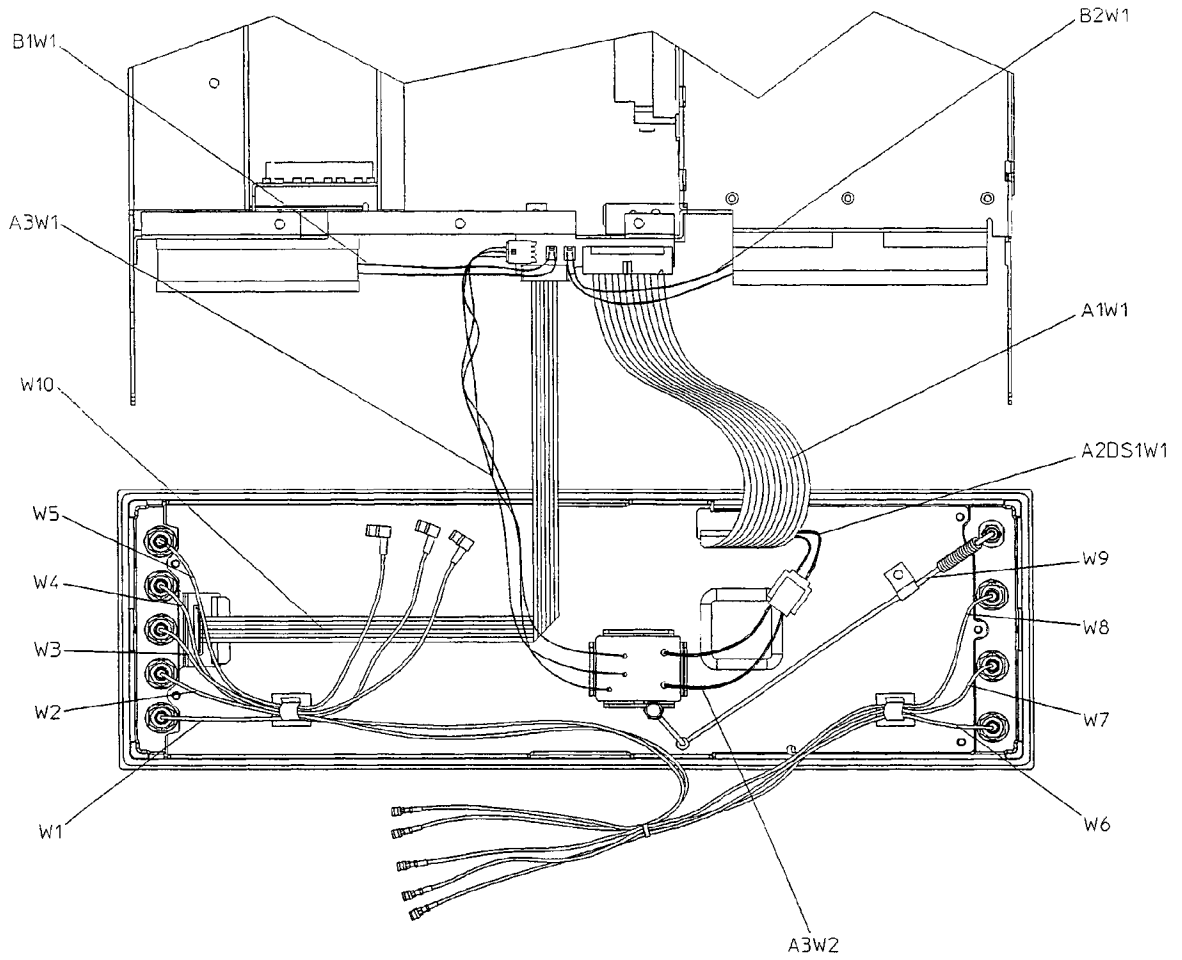

sk705a

Inside Front Panel View

NOTE:

The figure above represents an Option 1EH, UN3, or UN4 front panel assembly. On a standard model, W3, W4, and W5 do not exist and the front panel connectors for W1 and W2 will be in a slightly different location.

Replaceable Parts
Cables

Attenuator View

Reference Designator	HP Part Number	Qty	Description
W1	8120-6758	1	I IN to Daughterboard (A15J2)
W2	8120-6758	1	Q IN to Daughterboard (A15J3)
W6	8120-6758	1	EXT 1 to Daughterboard (A15J4)
W7	8120-6758	1	EXT 2 to Daughterboard (A15J5)
W8	8120-6758	1	LF OUTPUT to Daughterboard (A15J6)
W9	E4400-20018	1	RF OUTPUT to Electronic Attenuator/RPP (AT1)
W11	E4400-60059	1	Output Board (A9) to Synthesizer/Doubler Board (A12) (includes cable retainer and ring)
W12	E4400-60060	1	Output Board (A9) to COHERENT CARRIER (includes cable retainer and ring)
W13	8120-6837	1	Electronic Attenuator/RPP (AT1) to CPU/Motherboard (A14J14)
W14	E4400-60061	1	Electronic Attenuator/RPP (AT1) to Output Board (A9) (includes cable retainer and ring)

Replaceable Parts
Cables

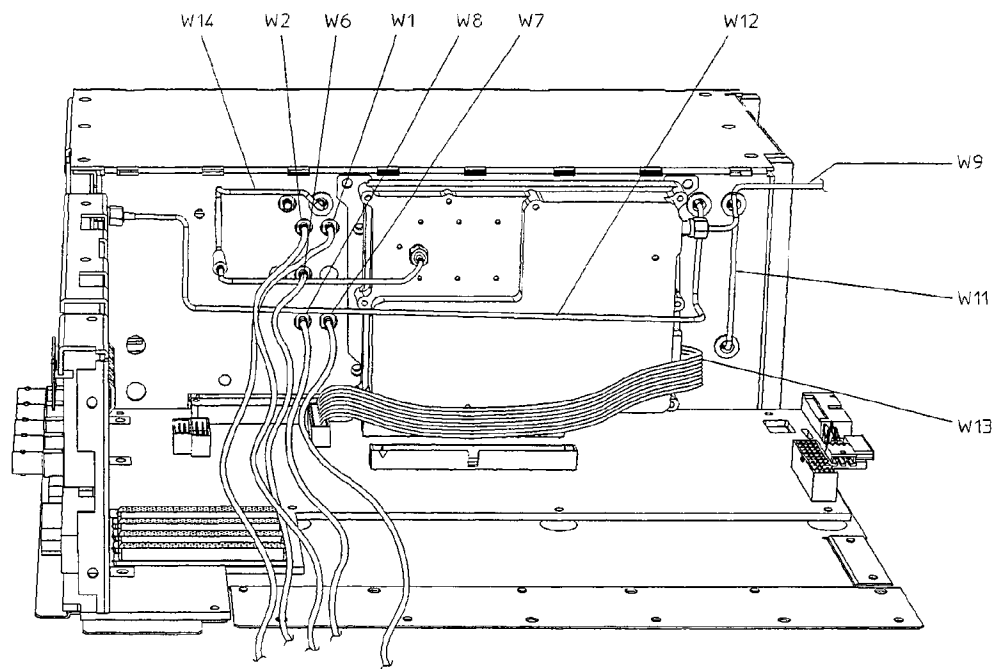

sk708a

Attenuator View

Replaceable Parts
Cables

Attenuator View (Option 1EM)

Reference Designator	HP Part Number	Qty	Description
W1	8120-6839	1	I IN to Daughterboard (A15J2)
W2	8120-6839	1	Q IN to Daughterboard (A15J3)
W6	8120-6839	1	EXT 1 to Daughterboard (A15J4)
W7	8120-6839	1	EXT 2 to Daughterboard (A15J5)
W8	8120-6839	1	LF OUTPUT to Daughterboard (A15J6)
W9	E4400-20025	1	RF OUTPUT to Electronic Attenuator/RPP (AT1)
W11	E4400-60059	1	Output Board (A9) to Synthesizer/Doubler Board (A12) (includes cable retainer and ring)
W12	E4400-60060	1	Output Board (A9) to COHERENT CARRIER (includes cable retainer and ring)
W13	8120-6837	1	Electronic Attenuator/RPP (AT1) to CPU/Motherboard (A14J14)
W14	E4400-60061	1	Electronic Attenuator/RPP (AT1) to Output Board (A9) (includes cable retainer and ring)

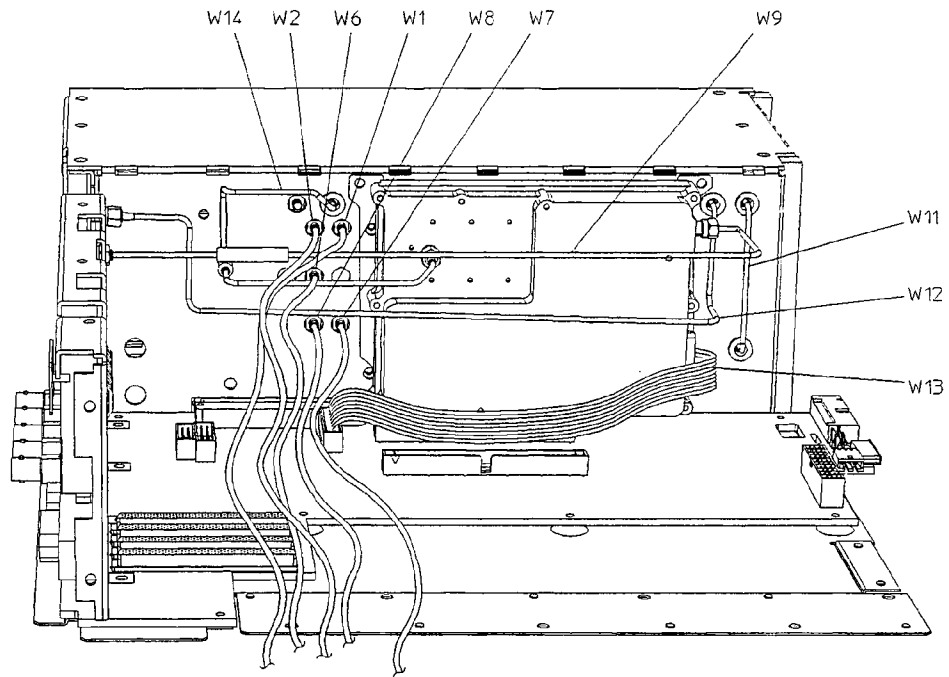

sk710a

Attenuator View (Option 1EM)

Replaceable Parts
Hardware and Other Instrument Parts

Hardware and Other Instrument Parts

Top View

Item No.	HP Part Number	Qty	Description
1	1400-0054	1	Clamp-Semi-Rigid Cable (W14)
2	0515-0372	1	Screw-Machine M3x8 CW-PN-TX
3	0515-0430	2	Screw-Machine M3x6 CW-PN-TX
4	1400-1594	1	Clamp-Flexible Cables (not used on Option 1EM)
5	0361-1341	4	Rivet-Plastic
6	0515-0374	4	Screw-Machine M3x10 CW-PN-TX
8	0400-0001	1	Grommet Round .562ID (not used on Option 1EM)
9	4320-0402	1	Channel NPR .062W (Options 1EH, UN3, UN4)
10	0400-0001	1	Grommet Round .562ID (Options 1EH/1EM, UN3/1EM, UN4/1EM)
11	0400-0001	1	Grommet Round .562ID (Option 1EM)

Replaceable Parts
Hardware and Other Instrument Parts

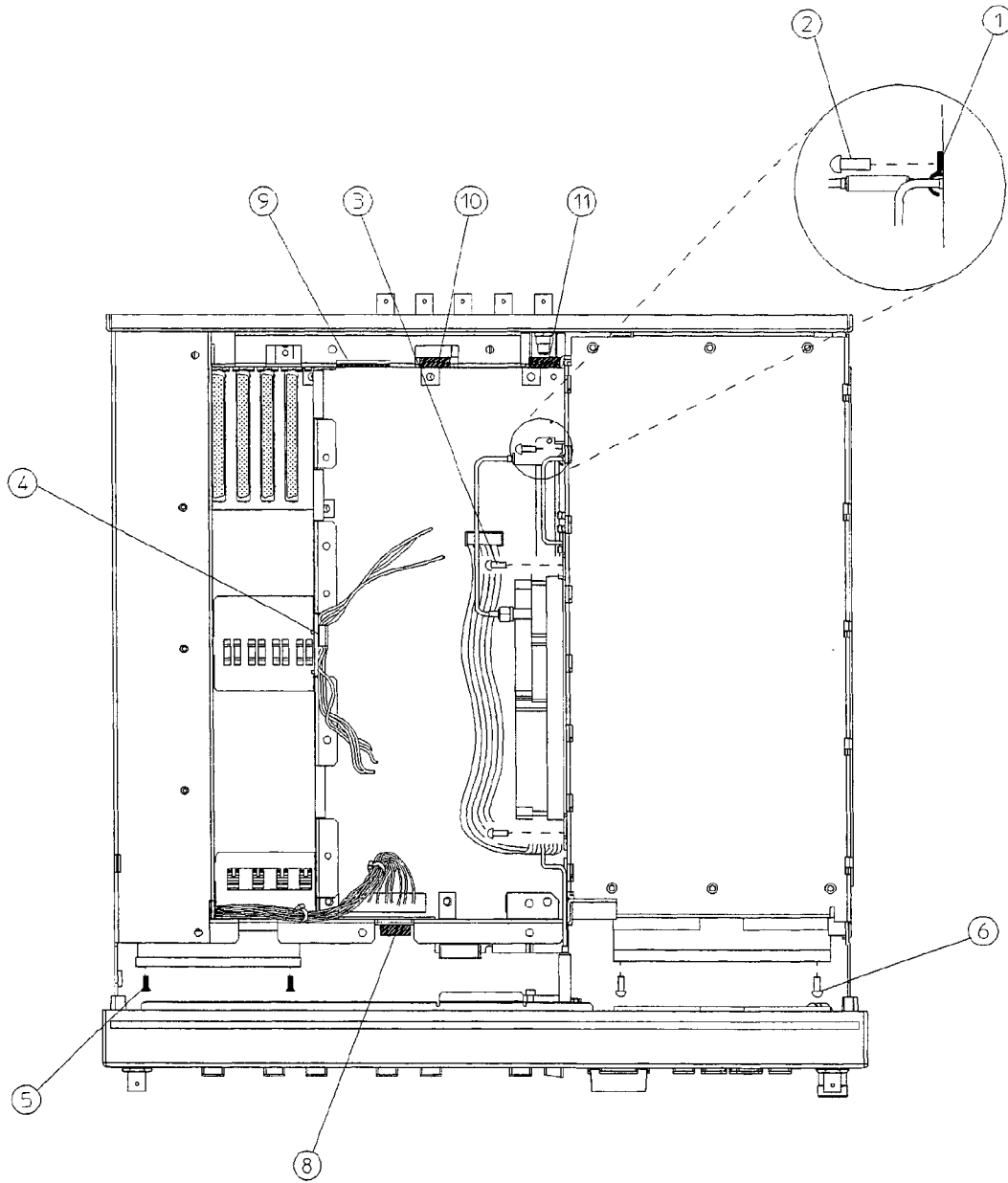

sk719a

Top View

Replaceable Parts
 Hardware and Other Instrument Parts

Front Panel View

Item No.	HP Part Number	Qty	Description
1	E4400-80010	1	Label-Connectors
1	E4400-80011	1	Label-Connectors (Option 1EM)
1	E4400-80006	1	Label-Connectors (Options 1EH, UN3, UN4)
2	E4400-80007	1	Nameplate-1 GHz ESG-D1000A
2	E4400-80008	1	Nameplate-2 GHz ESG-D2000A
2	E4400-80009	1	Nameplate-3 GHz ESG-D3000A
2	E4400-80012	1	Nameplate-4 GHz ESG-D4000A
3	E4400-40003	1	Knob-RPG
4	E4400-80005	1	Label-Keypad
4	E4400-80015	1	Label-Keypad (Option 1EM)
5	2950-0035	5 ¹	Nut-Hex 15/32-32
6	3050-1919	5 ¹	Washer-Wavy .490ID

1. Option 1EH uses a quantity of 8.

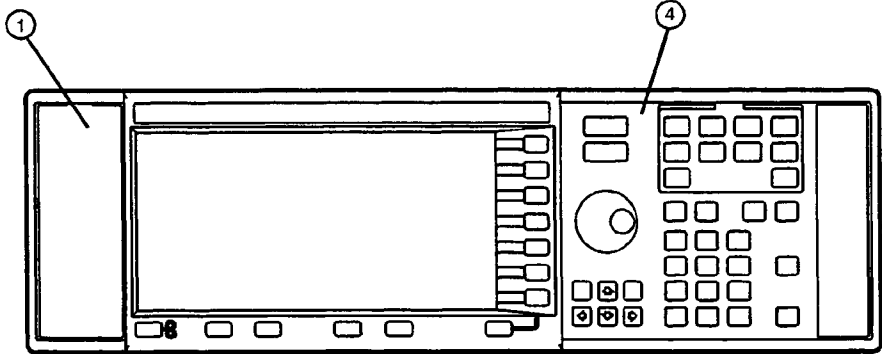
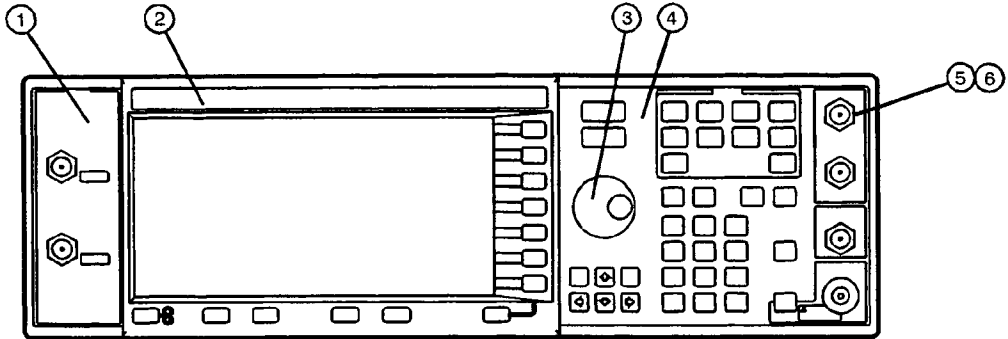

OPTION 1EM

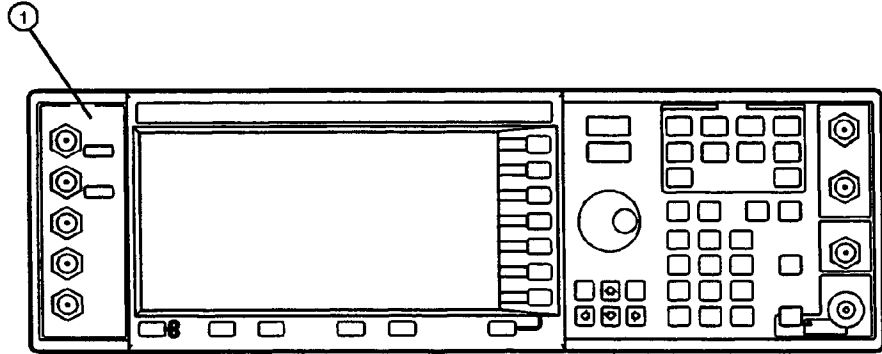

OPTIONS 1EH, UN3, UN4

Front Panel View

sk7126a

Replaceable Parts

Hardware and Other Instrument Parts

Disassembled Front Panel View

Item No.	HP Part Number	Qty	Description
1	1250-1811	1	Adapter-Female SMA to Female Type-N
2	E4400-20012	1	Frame-Front
3	3050-1935	1	Washer-Flat
4	2190-0383	1	Washer-Lock
5	2950-0054	1	Nut-Hex 1/2-28
6	E4400-40001	1	Rubber Keypad
7	0515-1521	14	Screw-Machine M3x5 FL-TX
8	0515-0372	4	Screw-Machine M3x8 CW-PN-TX
9	1400-1594	2	Clamp-Flexible Cables
10	0515-0372	8	Screw-Machine M3x8 CW-PN-TX
11	1400-0054	1	Clamp-Semi-Rigid Cable (W9)
12	1400-1533	1	Clamp-Ribbon Cable (A1W1)
13	1400-0493	1	Cable Tie Wrap
14	1400-0611	1	Clamp-Ribbon Cable (W10)
15	E4400-00008	1	Front Frame RFI Shield
16	E4400-00009	1	Filter Bracket
17	4330-1711	1	Glass Filter 70% XMT
18	E4400-40008	1	Light Pipe
19	8160-0723	2 Ft	Spiral Gasket-BC CY .094
20	8160-0660	4 Ft	RFI Round Mesh.125

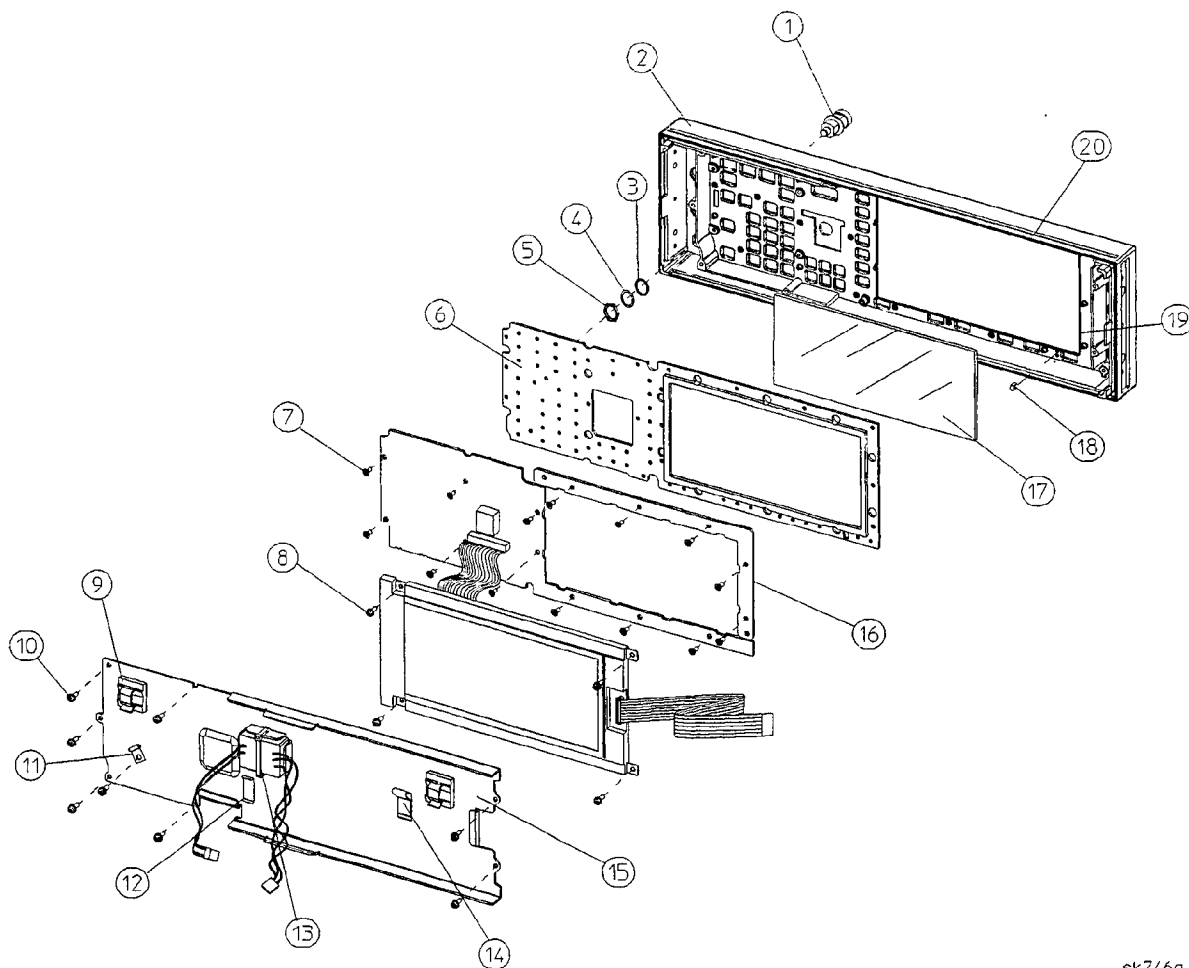

sk746a

Disassembled Front Panel View

Replaceable Parts
Hardware and Other Instrument Parts

Daughterboard Card Cage View

Item No.	HP Part Number	Qty	Description
1	E4400-40002	4	Retainer-Cable
2	0510-1643	4	Retainer Ring .309ID
3	0515-0430	5	Screw-Machine M3x6 CW-PN-TX

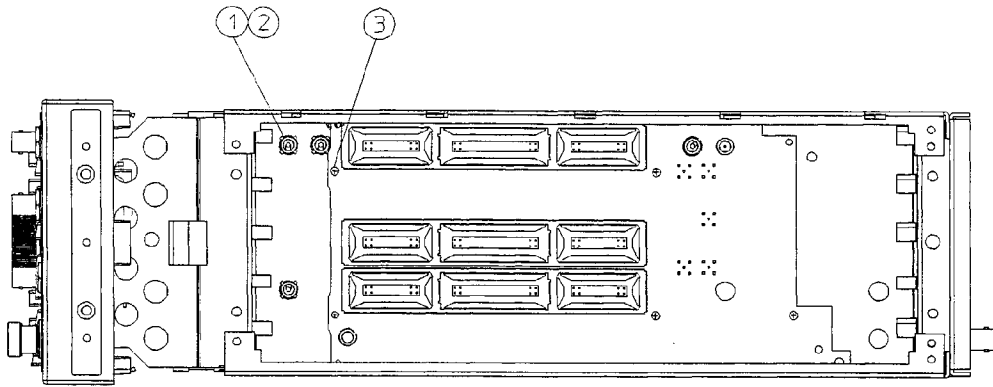

sk707c

Daughterboard Card Cage View

Replaceable Parts
Hardware and Other Instrument Parts

Rear Panel View

Item No.	HP Part Number	Qty	Description
1	0515-0372	10	Screw-Machine M3x8 CW-PN-TX
2	E4400-00002	1	Panel-Rear
2	E4400-00016	1	Panel-Rear (Options 1EH, UN3, UN4)
3	0515-0372	1	Screw-Machine M3x8 CW-PN-TX (used to attach item 4))
4	1250-2759	1	Dust Cap Female SMA
5	1250-1753	1	Adapter-Female SMA to Female SMA
7	E4400-00017	1	Serial Number Plate
8	0515-1102	2	Screw-Machine M3x8 FL-TX
9	0380-0644	2	Standoff-Hex .327L 6-32
10	2190-0577	2	Washer-Lock
11	0380-2079	2	Standoff-Hex .312L 4-40
12	2190-0003	2	Washer-Lock
13	6960-0002	3	Plug-Hole .500D (Options 1EH, UN3, UN4)
14	2950-0054	5	Nut-Hex 1/2-28
15	2190-0068	5	Washer-Lock .505ID
16	2950-0035	11	Nut-Hex 15/32-32 (Options 1EH, UN3, UN4)
17	2190-0102	11	Washer-Lock .472ID (Options 1EH, UN3, UN4)

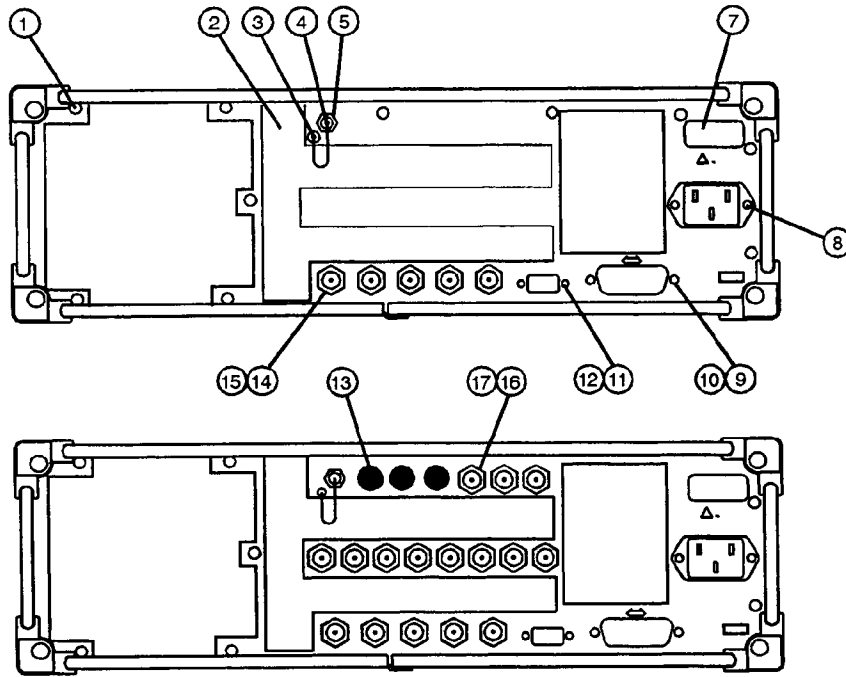

Options 1EH, UN3, UN4

sk7127a

Rear Panel View

Replaceable Parts
Hardware and Other Instrument Parts

Rear Panel View (Option 1EM)

Item No.	HP Part Number	Qty	Description
1	0515-0372	10	Screw-Machine M3x8 CW-PN-TX
2	E4400-00010	1	Panel-Rear
3	0515-0372	1	Screw-Machine M3x8 CW-PN-TX (used to attach item 4)
4	1250-2759	1	Dust Cap Female SMA
5	1250-1753	1	Adapter-Female SMA to Female SMA
7	2950-0035	5	Nut-Hex 15/32-32
8	2190-0102	5	Washer-Lock .472ID
9	08559-60002	1	RF Output Assy
10	2950-0132	1	Nut-Hex 7/16-28
11	2190-0102	1	Washer-Lock
13	E4400-00017	1	Serial Number Plate
14	0515-1102	2	Screw-Machine M3x8 FL-TX
15	0380-0644	2	Standoff-Hex .327L 6-32
16	2190-0577	2	Washer-Lock
17	0380-2079	2	Standoff-Hex .312L 4-40
18	2190-0003	2	Washer-Lock
19	2950-0054	5	Nut-Hex 1/2-28
20	2190-0068	5	Washer-Lock .505ID
21	E4400-00018	1	Panel-Rear (Options 1EH, UN3, UN4)
22	2950-0078	14	Nut-Hex 10-32 (for the SMBs) (Options 1EH, UN3, UN4)
23	2190-0124	14	Washer-Lock .195ID (for the SMBs) (Options 1EH, UN3, UN4)

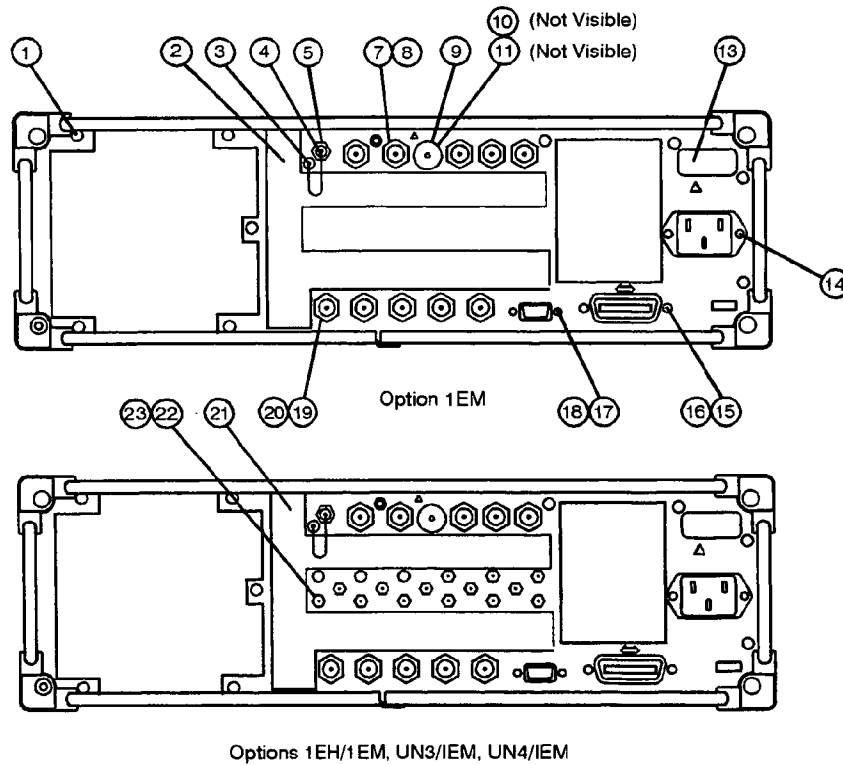

sk7128a

Rear Panel View (Option 1EM)

Replaceable Parts
Hardware and Other Instrument Parts

Inside Rear Panel View

Item No.	HP Part Number	Qty	Description
1	0535-0031	1	Nut-Hex M3.0
2	0535-0031	1	Nut-Hex M3.0

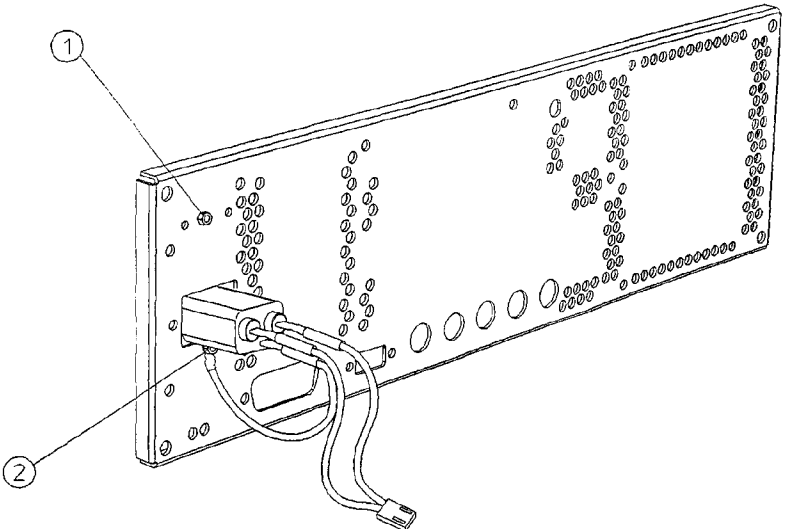

sk754a

Inside Rear Panel View

Replaceable Parts
Hardware and Other Instrument Parts

Instrument Chassis with Top and Right-Side Hardware

Item No.	HP Part Number	Qty	Description
1	0515-1269	2	Screw-Machine M4X10 FL-TX
2	0515-2087	4	Screw-Machine M3x6 CW-BN-TX
3	E4400-00003	1	Cover-Side
4	E4400-00001	1	Chassis
5	E4400-00006	1	Cover-Top Chassis
6	0515-0430	11	Screw-Machine M3x6 CW-PN-TX
7	E4400-80018	1	Label-Connection Diagram (Option 1EH only)
7	E4400-80046	1	Label-Connection Diagram

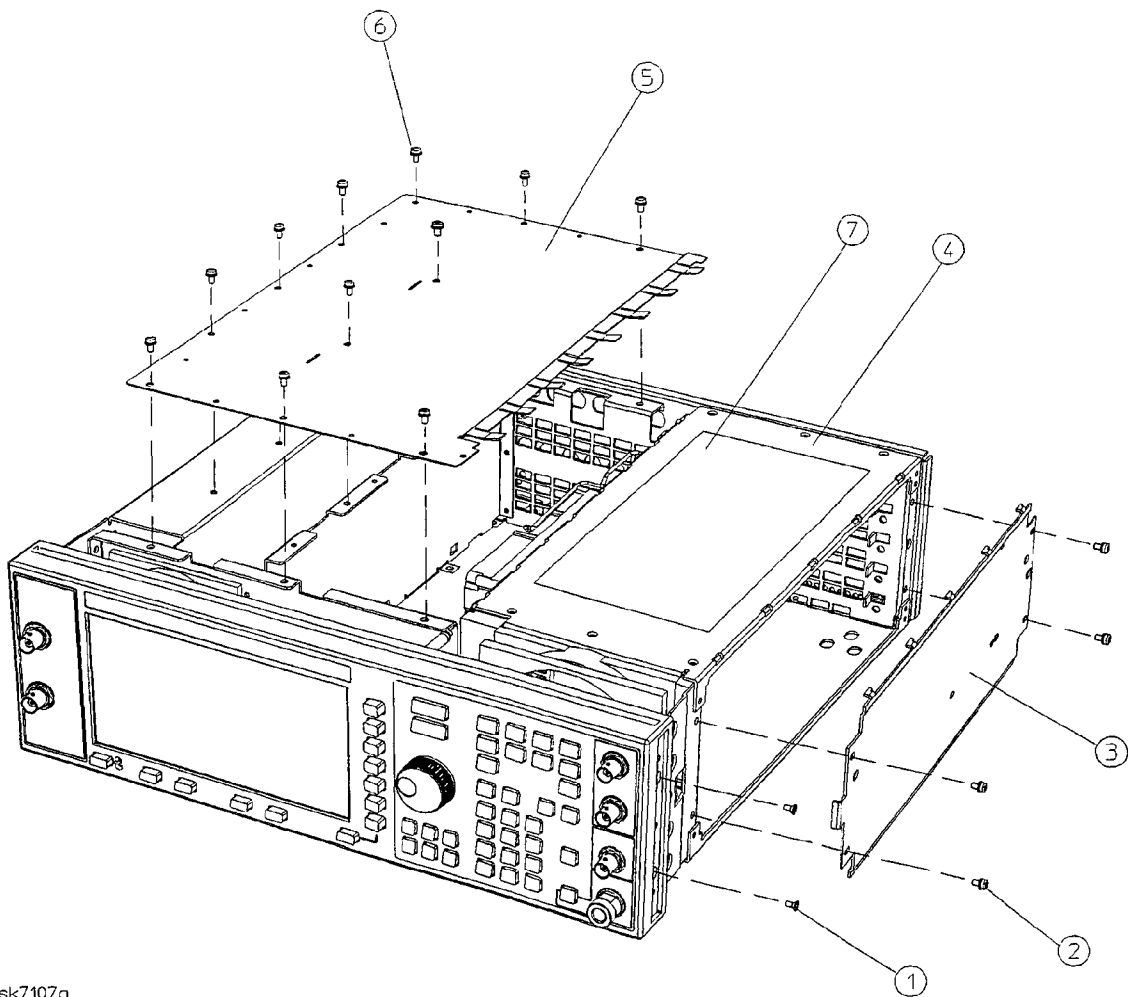

sk7107a

Instrument Chassis with Top and Right-Side Hardware

Replaceable Parts
Hardware and Other Instrument Parts

Power Supply Shield and Left-Side Hardware

Item No.	HP Part Number	Qty	Description
1	0515-1269	2	Screw-Machine M4X10 FL-TX
2	E4400-00011	1	Shield-Power Supply
3	0515-0372	17	Screw-Machine M3x8 CW-PN-TX

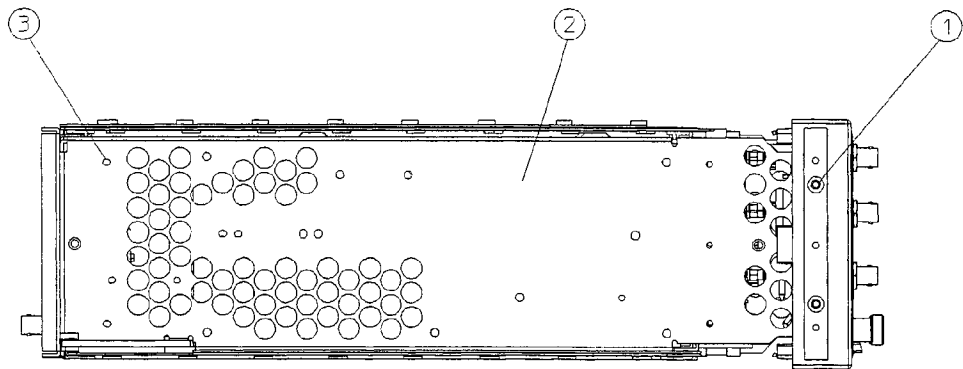

sk706a

Power Supply Shield with Left-Side Hardware

Replaceable Parts
Hardware and Other Instrument Parts

Motherboard and Bottom-Side Hardware

Item No.	HP Part Number	Qty	Description
1	0515-0372	15	Screw-Machine M3x8 CW-PN-TX
2	E4400-00007	1	Cover-Bottom Chassis
3	0515-0372	2	Screw-Machine M3x8 CW-PN-TX
4	0340-1162	1	Insulator Bushing .119ID
5	0340-1216	1	Insulator-Transistor

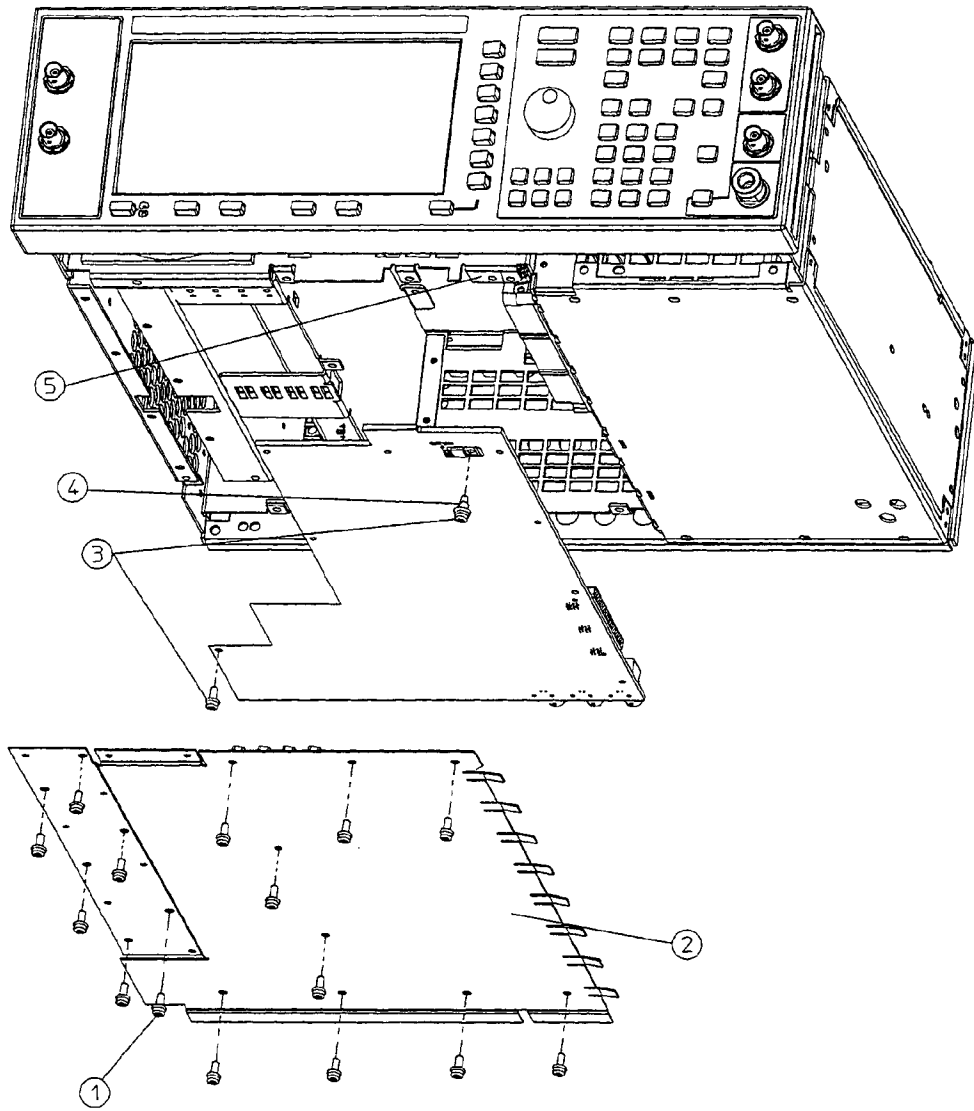

sk7106a

Motherboard and Bottom-Side Hardware

Replaceable Parts
Hardware and Other Instrument Parts

Instrument Cover and Associated Parts

Item No.	HP Part Number	Qty	Description
1	0515-1619	4	Screw-Machine M4x25 PN-TX
2	5182-1275	4	Foot-Rear Long
3	5041-8801	4	Feet-Bottom
4	1460-1345	2	Spring-Wire Frame 3.000 Long
5	5041-9171	2	Side Trim
6	E4400-60026	2	Assy-Strap Handle
7	E4400-00004	1	Cover-Instrument

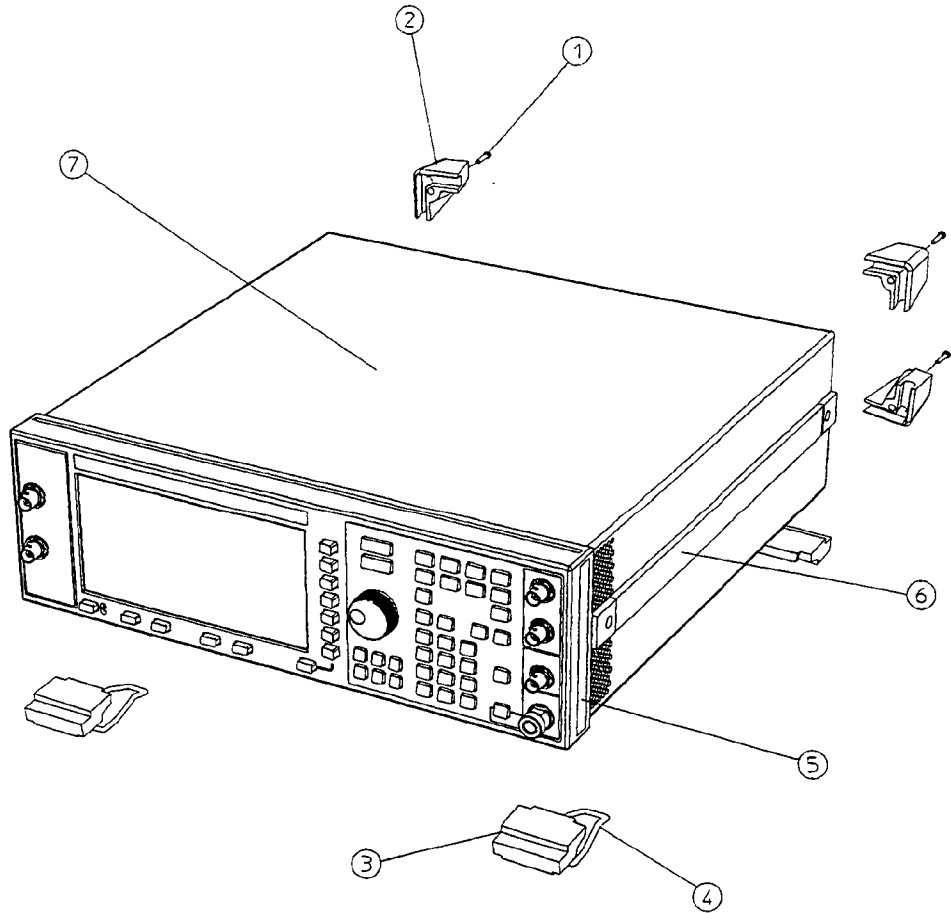

sk7105a

Instrument Cover and Associated Parts

Replaceable Parts
Miscellaneous

Miscellaneous

Accessories

Description	HP Part Number
Connector End Cap-RF Output	1401-0247
Connector End Cap-HP-IB	1401-5007
Connector End Cap-Aux Out	1252-4696
HP-IB Cable, 1M (3.3 Ft)	HP 10833A
HP-IB Cable, 2M (6.6 Ft)	HP 10833B
HP-IB Cable, 4M (13.2 Ft)	HP 10833C
HP-IB Cable, 0.5M (1.6 Ft)	HP 10833D
Remote Interface	HP 83300A
Transit Case	9211-1296

Documentation

Description	HP Part Number
HP ESG Series Signal Generators Manual Set (includes the four manuals listed below)	E4400-90075
HP ESG Series Signal Generators User's Guide	E4400-90076
HP ESG Series Signal Generators Programming Guide	E4400-90077
HP ESG Series Signal Generators Quick Reference Guide	E4400-90078
HP ESG Series Signal Generators Calibration Guide	E4400-90079
HP ESG Series Signal Generators Service Guide	E4400-90008
HP ESG-D Series Signal Generators Manual Set (includes the four manuals listed below)	E4400-90080
HP ESG-D Series Signal Generators User's Guide	E4400-90081
HP ESG-D Series Signal Generators Programming Guide	E4400-90082
HP ESG-D Series Signal Generators Quick Reference Guide	E4400-90083
HP ESG-D Series Signal Generators Calibration Guide	E4400-90084
HP ESG-D Series Signal Generators Service Guide	E4400-90014
HP ESG Series and HP ESG-D Series Signal Generators Component-Level Information	E4400-90015
HP ESG Series Signal Generators User's Guide - Chinese	E4400-90022
HP ESG Series Signal Generators User's Guide - Korean	E4400-90023
HP ESG Series Signal Generators User's Guide - Taiwanese	E4400-90024
HP ESG Series Signal Generators User's Guide - Japanese	E4400-90025

Documentation

Description	HP Part Number
HP ESG Series Signal Generators User's Guide - Spanish	E4400-90026
HP ESG Series Signal Generators User's Guide - German	E4400-90027
HP ESG-D Series Signal Generators User's Guide - Chinese	E4400-90028
HP ESG-D Series Signal Generators User's Guide - Korean	E4400-90029
HP ESG-D Series Signal Generators User's Guide - Taiwanese	E4400-90030
HP ESG-D Series Signal Generators User's Guide - Japanese	E4400-90031
HP ESG-D Series Signal Generators User's Guide - Spanish	E4400-90032
HP ESG-D Series Signal Generators User's Guide - German	E4400-90033

ESD Supplies

Description	HP Part Number
2 X 4 Ft Antistatic Table Mat with 15 Ft Ground Wire	9300-0797
5 Ft Grounding Cord (for wrist strap)	9300-0980
Adjustable Antistatic Wrist Strap	9300-1367
Antistatic Heel Strap (for use on conductive floors)	9300-1126

Kits

Description	HP Part Number
Kit-Firmware Upgrade (RS-232 cable not included - <i>must order separately</i>)	E4400-60046
Kit-Firmware Upgrade with ESG Series Manual Set (RS-232 cable not included - <i>must order separately</i>)	E4400-60054
Kit-Firmware Upgrade with ESG-D Series Manual Set (RS-232 cable not included - <i>must order separately</i>)	E4400-60055
Kit-RS-232 Cable	E4400-60049
Kit-Rack Mount Flanges without Handles (Option 1CM)	5063-9214
Kit-Rack Mount Flanges with Handles (Option 1CP)	5063-9221
Retrofit Kit-Converts Analog Models (ESG Series) to Digital (ESG-D Series)	E4400-60047
Retrofit Kit-High Stability Timebase (conversion to Option 1E5)	E4400-60032

Replaceable Parts
Miscellaneous



4 Assembly Replacement

This chapter provides removal and replacement procedures for the major assemblies of your signal generator.

Before You Replace an Assembly

Avoid Personal Injury

WARNING: These servicing instructions are for use by qualified personal only. To avoid electrical shock, do not perform any servicing unless you are qualified to do so.

WARNING: The opening of covers or removal of parts is likely to expose dangerous voltages. Disconnect the product from all voltage sources while it is being opened.

WARNING: The detachable power cord is the instrument disconnecting device. It disconnects the mains circuits from the mains supply before other parts of the instrument. The front panel switch is only a standby switch and is not a LINE switch.

WARNING: The power cord is connected to internal capacitors that may remain live for 5 seconds after disconnecting the plug from its power supply.

Prevent ESD Damage

CAUTION: Many of the assemblies in this instrument are very susceptible to damage from ESD (electrostatic discharge). Perform service procedures only at a static-safe workstation and wear a grounding strap.

Assemblies That You Can Replace

This chapter provides removal and replacement procedures for the following assemblies:

- Instrument Cover
- Front Panel
- Front Panel (Option 1EM)
- Rear Panel
- Rear Panel (Option 1EM)
- A1 Front Panel Board
- A2 Display
- A2DS1 Fluorescent Lamp
- A3 Inverter
- A4 Power Supply
- A4 Power Supply (Option 1EM)
- A7 Baseband Generator Board (Option 1EH)
- A7 Baseband Generator Board (Options UN3 & UN4)
- A8 Data Generator Board (Options UN3 & UN4)
- A9, A11, and A12 Daughterboard Card Cage Boards
- A14 CPU/Motherboard
- A14BT1 Battery
- A15 Daughterboard
- A16 Line Module
- A17 Rear Panel Interface Board (Options 1EH, UN3, UN4)
- AT1 Electronic Attenuator/RPP
- B1 Small Fan Assembly
- B2 Large Fan Assembly
- W11, W12, and W14 Semi-Rigid Cables

After Replacing an Assembly

After you have replaced or repaired an assembly, certain performance tests and adjustments may have to be performed. Chapter 5, "Post-Repair Procedures," lists the performance tests and adjustments required for each assembly.

Instrument Cover

Tools Required

- T-15 TORX screwdriver
- T-20 TORX screwdriver

Removal

1. Remove the two strap handles (item 1) from each side of the signal generator by loosening the two screws (item 2) on each handle.
2. Remove the four bottom feet (item 3).
3. Remove the four rear feet (item 4) from the signal generator by removing the four screws (item 5) that secure them.
4. Slide the instrument cover (item 6) off the back of the signal generator.

Replacement

1. Reverse the removal procedure and do the following:
 - Torque the rear feet screws (item 4) to 21 in-lbs.
 - Torque the strap handle screws (item 2) to 21 in-lbs.

Assembly Replacement
Instrument Cover

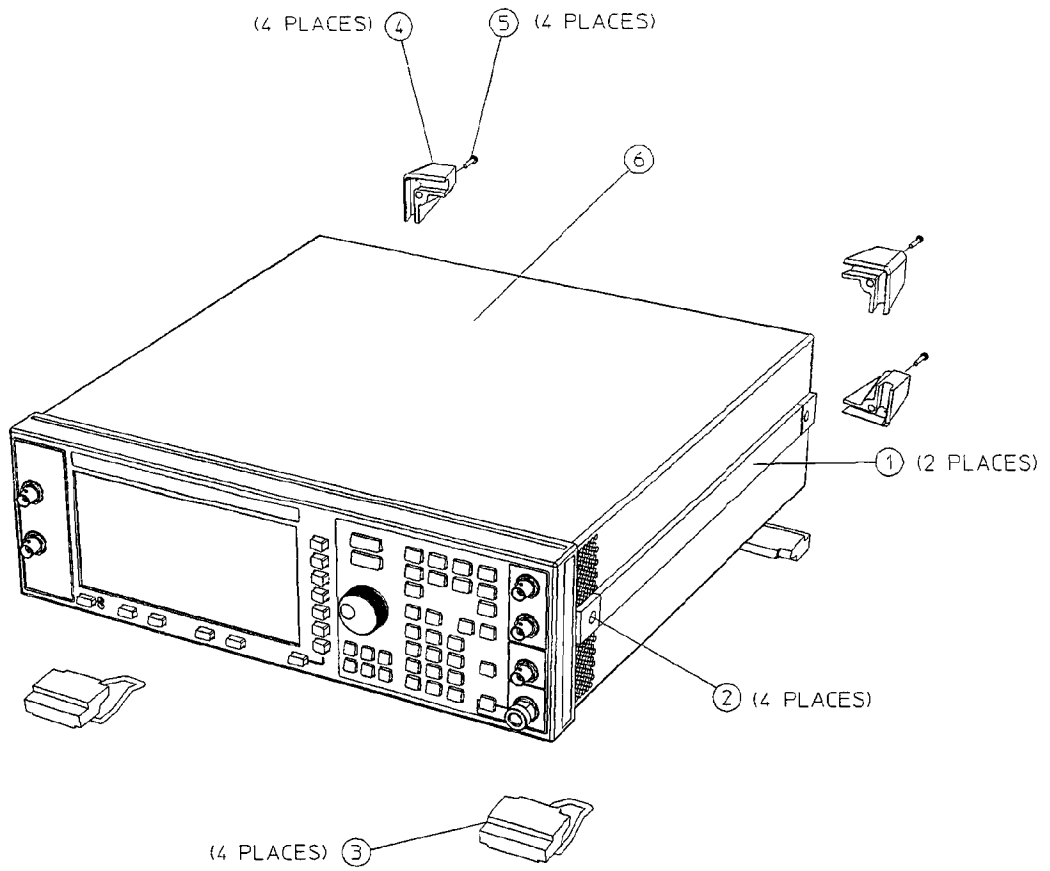

sk7104c

Instrument Cover

Front Panel

Tools Required

- T-10 TORX screwdriver
- T-15 TORX screwdriver
- 5/16-inch open-end wrench
- long nose pliers (used for disconnecting wires from the daughterboard)

Removal

1. Remove the instrument cover. (Refer to "Instrument Cover" in this chapter.)
2. Remove the top cover by removing the 11 screws that secure it.
3. Disconnect A1W1, A3W1, and W10 from the motherboard (A14). To disconnect W10 you must first unlock the motherboard connector by pulling out the locking mechanism (much like pulling out a drawer).
4. Disconnect W1, W2, W6, W7, and W8 from the daughterboard (A15).
5. If you have Option UN3 or UN4, disconnect W3, W4, and W5 from the data generator board (A8).
If you have Option 1EH, disconnect W3, W4, and W5 from the baseband generator board (A7).

NOTE: The figure on the adjacent page represents an Option UN3 or UN4. Option 1EH is not shown.

6. Disconnect W9 from the electronic attenuator/RPP (AT1).

Assembly Replacement
Front Panel

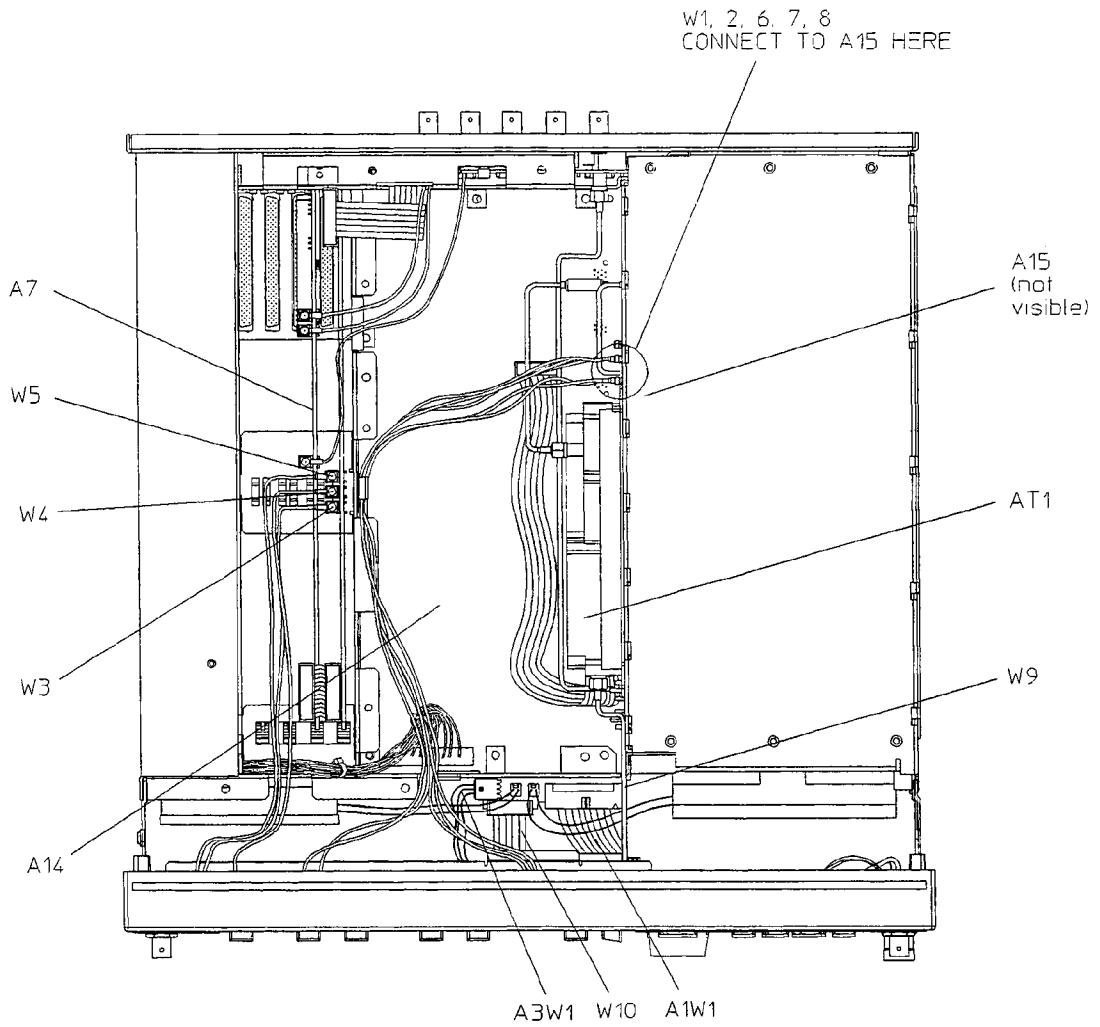

sk7124a

Front Panel (1 of 2)

Assembly Replacement

Front Panel

7. Carefully peel off the side trim (item 1) from the sides of the front panel assembly (item 2).
8. Remove the four screws (item 3) that attach the front panel assembly to the instrument chassis.
9. Pull the front panel assembly away from the instrument chassis.

Replacement

1. Reverse the removal procedure and do the following:
 - Refer to Chapter 3, "Replaceable Parts," to verify that the cables are reconnected in the correct locations.
 - To reconnect W10 to its motherboard connector do the following:
 - a Ensure the motherboard connector is unlocked by pulling out the locking mechanism (much like pulling out a drawer).
 - b Insert W10 into the connector making sure the conductive contacts are facing up (the blue insulation should be facing down).
 - c Lock the connector by pushing in on the locking mechanism.

NOTE: Intermittent display problems may result if W10 is not connected correctly.

- Torque W9 to 9 in-lbs.
- Torque all T-10 TORX screws to 9 in-lbs.
- Torque all T-15 TORX screws to 21 in-lbs.

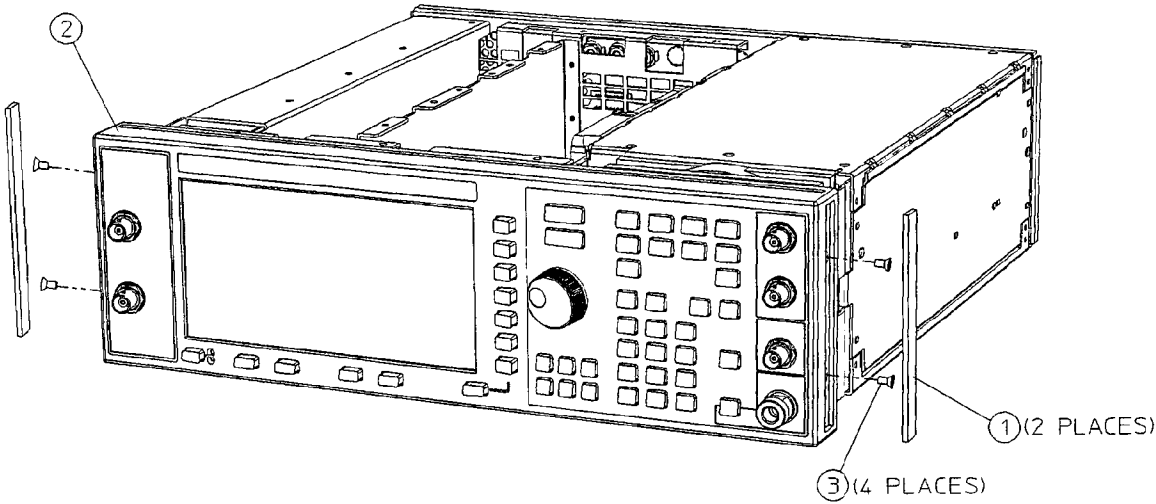

sk7103a

Front Panel (2 of 2)

Front Panel (Option 1EM)

Tools Required

- T-10 TORX screwdriver
- T-15 TORX screwdriver

Removal

1. Remove the instrument cover. (Refer to "Instrument Cover" in this chapter.)
2. Remove the top cover by removing the 11 screws that secure it.
3. Disconnect A1W1, A3W1, and W10 from the motherboard (A14). To disconnect W10 you must first unlock the motherboard connector by pulling out the locking mechanism (much like pulling out a drawer).

Assembly Replacement
Front Panel (Option 1EM)

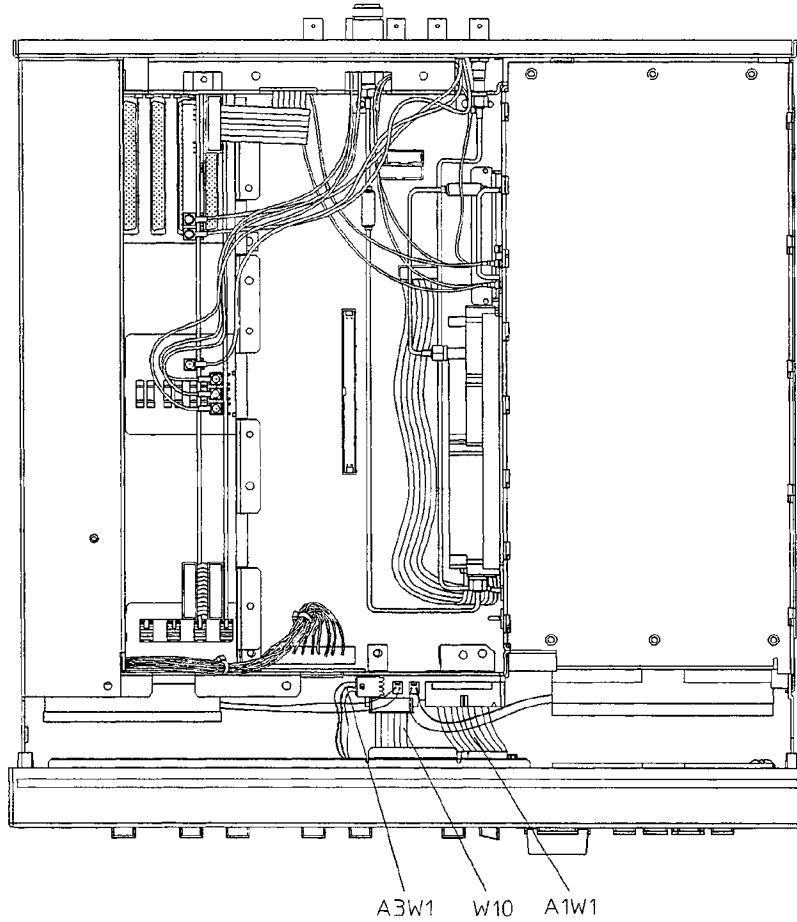

sk7135a

Front Panel (Option 1EM) (1 of 2)

Assembly Replacement
Front Panel (Option 1EM)

4. Carefully peel of the side trim (item 1) from the sides of the front panel assembly (item 2).
5. Remove the four screws (item 3) that attach the front panel assembly to the instrument chassis.
6. Pull the front panel assembly away from the instrument chassis.

Replacement

1. Reverse the removal procedure and do the following:
 - Refer to Chapter 3, "Replaceable Parts," to verify that the cables are reconnected in the correct locations.
 - To reconnect W10 to its motherboard connector do the following:
 - a Ensure the motherboard connector is unlocked by pulling out the locking mechanism (much like pulling out a drawer).
 - b Insert W10 into the connector making sure the conductive contacts are facing up (the blue insulation should be facing down).
 - c Lock the connector by pushing in on the locking mechanism.

NOTE: Intermittent display problems may result if W10 is not connected correctly.

- Torque all T-10 TORX screws to 9 in-lbs.
- Torque all T-15 TORX screws to 21 in-lbs.

Assembly Replacement
Front Panel (Option 1EM)

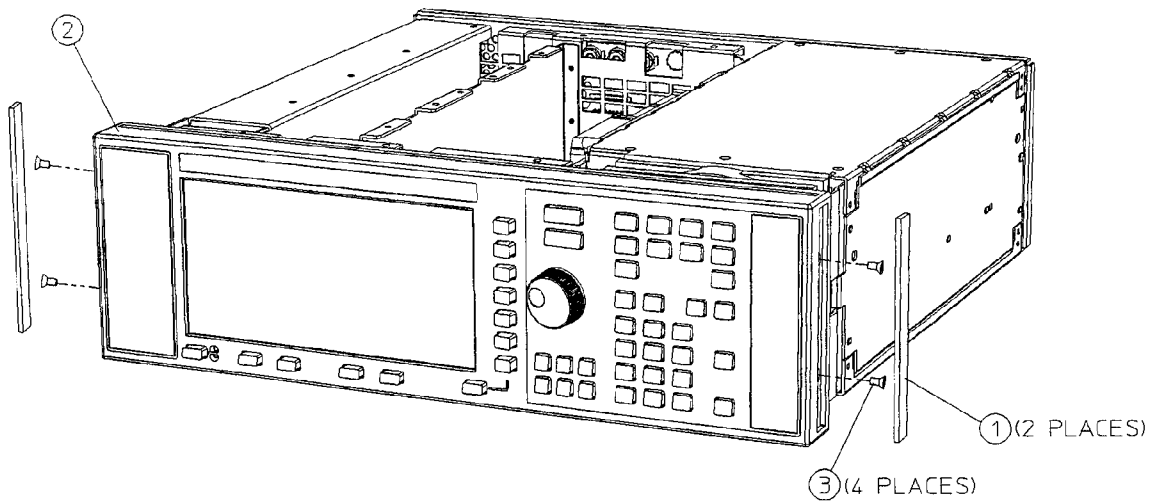

sk7102a

Front Panel (Option 1EM) (2 of 2)

Rear Panel

Tools Required

- T-10 TORX screwdriver
- 3/16-inch wrench or nut driver
- 9/32-inch wrench or nut driver
- 5/16-inch open-end wrench
- 5/8-inch wrench or nut driver
- long nose pliers

Removal

1. Remove the instrument cover. (Refer to "Instrument Cover" in this chapter.)
2. Remove the top cover by removing the 11 screws that secure it.
3. Remove the bottom cover by removing the 15 screws that secure it.
4. Disconnect A16W1 from the power supply (A4). A16W1 can be accessed through an opening on the bottom of the power supply shield (item 1).
5. If you have Option UN3 or UN4, disconnect A17W1 from the data generator board (A8). Disconnect W15, W16, and W17 from the baseband generator board (A7).

If you have Option 1EH, disconnect A17W1, W15, W16, and W17 from the baseband generator board (A7).

NOTE: The figure on the adjacent page represents an Option UN3 or UN4. Option 1EH is not shown.

6. Disconnect W12 from the adapter assembly on the rear panel.

Assembly Replacement
Rear Panel

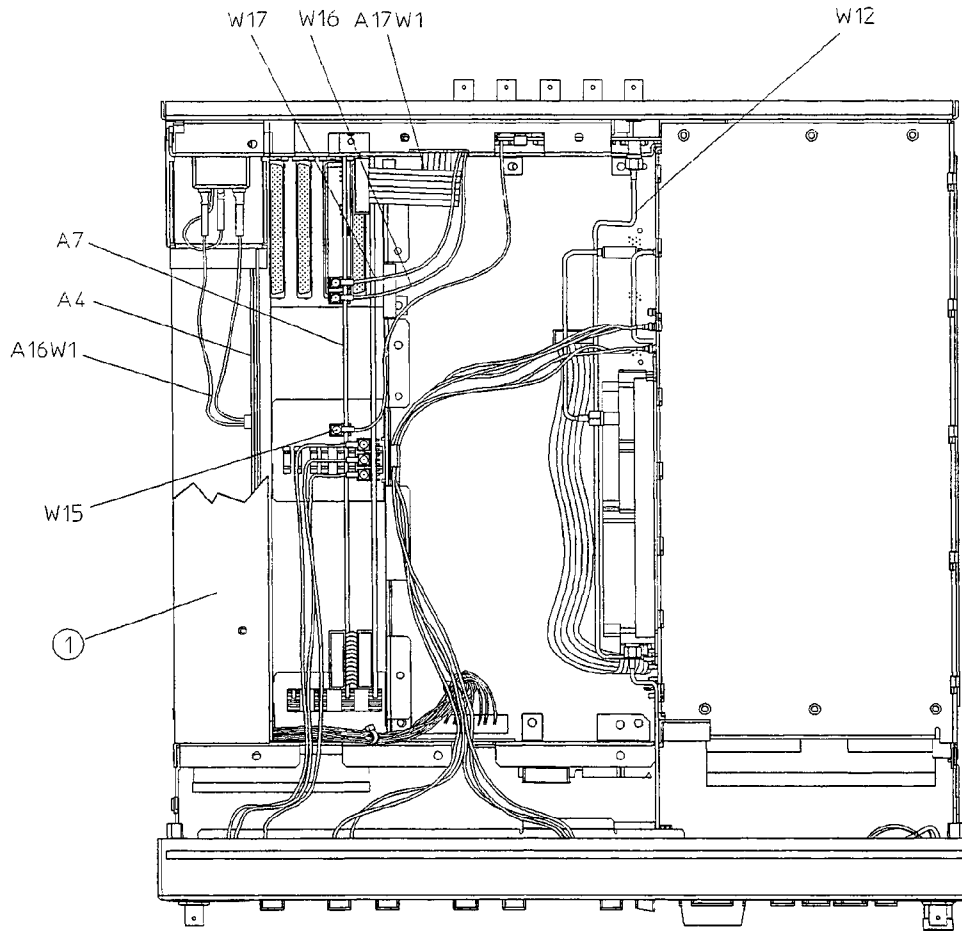

sk7140a

Rear Panel (1 of 2)

Assembly Replacement

Rear Panel

7. Remove the nuts and washers securing the five BNC connectors (item 1) at the base of the rear panel.
8. Remove the hex screws and washers that secure the AUXILARY INTERFACE (item 2) and the HP-IB connector (item 3) to the rear panel.
9. Remove the 10 screws (item 4) that secure the rear panel to the instrument chassis. Do not remove the screw that secures the chain and cap for COHERENT CARRIER connector.
10. Pull the rear panel assembly away from the instrument chassis.

Replacement

1. Reverse the removal procedure and do the following:
 - Torque all T-10 TORX screws to 9 in-lbs.
 - Torque the AUXILARY INTERFACE hex screws to 6 in-lbs.
 - Torque the HP-IB hex screws to 9 in-lbs.
 - Torque the five BNC connector nuts to 21 in-lbs.
 - Torque W12 to 9 in-lbs.
 - Refer to Chapter 3, "Replaceable Parts," to verify that the cables are reconnected in the correct locations.

Assembly Replacement
Rear Panel

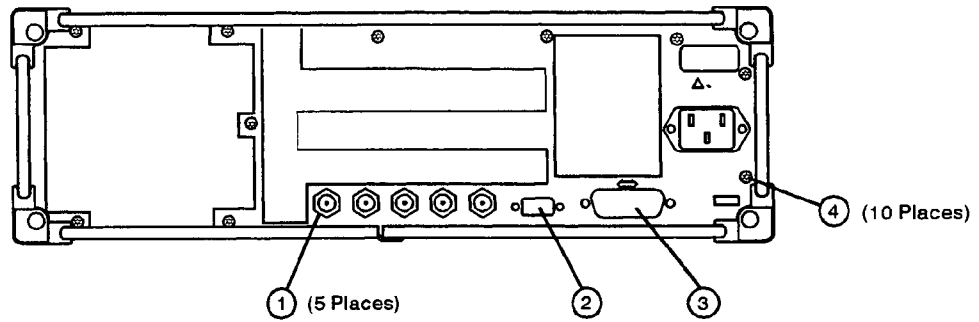

sk778a

Rear Panel (2 of 2)

Rear Panel (Option 1EM)

Tools Required

- T-10 TORX screwdriver
- 3/16-inch wrench or nut driver
- 9/32-inch wrench or nut driver
- 5/16-inch open-end wrench
- 5/8-inch wrench or nut driver
- long nose pliers

Removal

1. Remove the instrument cover. (Refer to "Instrument Cover" in this chapter.)
2. Remove the top cover by removing the 11 screws that secure it.
3. Remove the bottom cover by removing the 15 screws that secure it.
4. Disconnect A16W1 from the power supply (A4). A16W1 can be accessed through an opening on the bottom of the power supply shield (item 1).
5. Disconnect W1, W2, W6, W7, and W8 from the daughterboard (A15).
6. If you have Option UN3 or UN4, disconnect A17W1, W3, W4, and W5 from the data generator board (A8). Disconnect W15, W16, and W17 from the baseband generator board (A7).

If you have Option 1EH, disconnect A17W1, W3, W4, W5, W15, W16, and W17 from the baseband generator board (A7).

NOTE: The figure on the adjacent page represents an Option UN3 or UN4. Option 1EH is not shown.

7. Disconnect W9 from the adapter assembly on the rear panel.
8. Disconnect W12 from the adapter assembly on the rear panel.

Assembly Replacement
Rear Panel (Option 1EM)

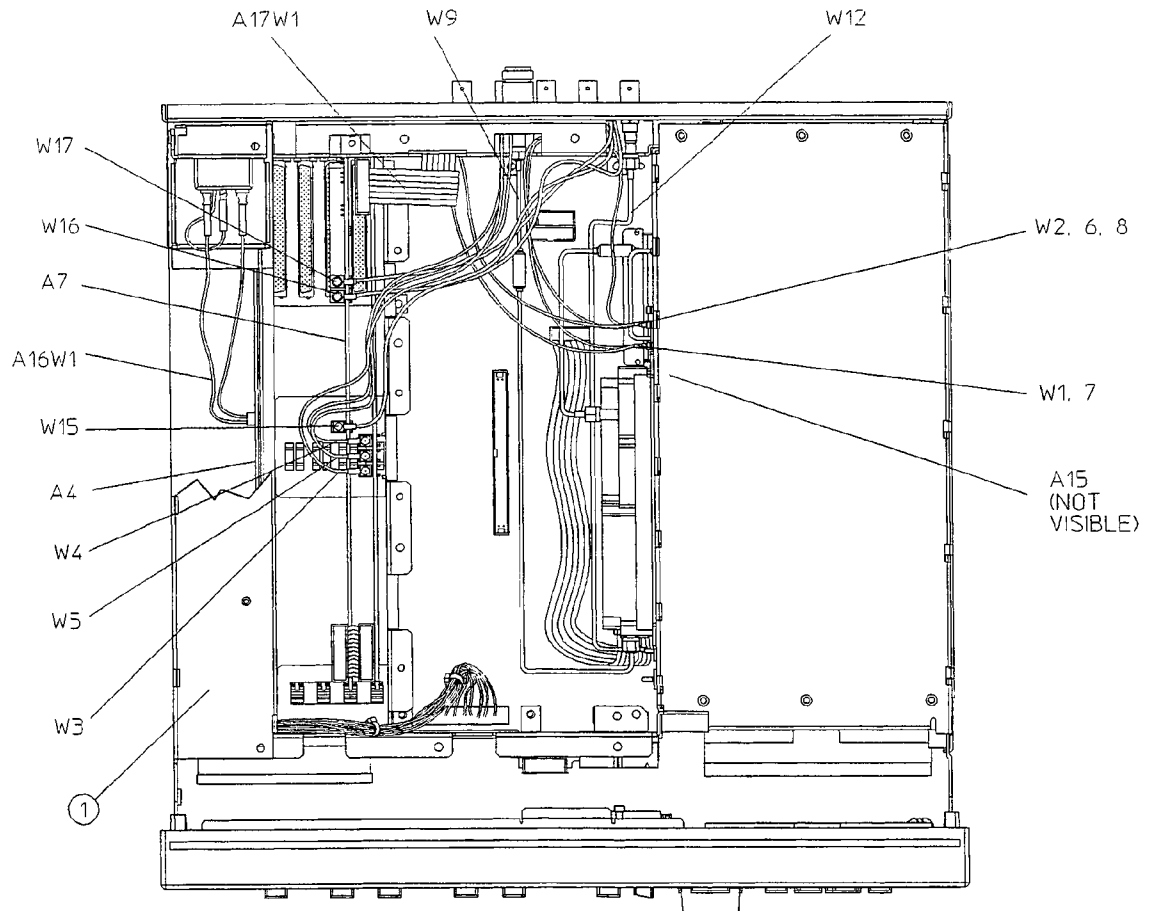

sk7139a

Rear Panel (Option 1EM) (1 of 2)

Assembly Replacement
Rear Panel (Option 1EM)

9. Remove the nuts and washers securing the five BNC connectors (item 1) at the base of the rear panel.
10. Remove the hex screws and washers that secure the AUXILARY INTERFACE (item 2) and the HP-IB connector (item 3) to the rear panel.
11. Remove the 10 screws (item 4) that secure the rear panel to the instrument chassis.
12. Pull the rear panel assembly away from the instrument chassis.

Replacement

1. Reverse the removal procedure and do the following:
 - Torque all T-10 TORX screws to 9 in-lbs.
 - Torque the AUXILARY INTERFACE hex screws to 6 in-lbs.
 - Torque the HP-IB hex screws to 9 in-lbs.
 - Torque the five BNC connector nuts to 21 in-lbs.
 - Torque W9 and W12 to 9 in-lbs.
 - Refer to Chapter 3, "Replaceable Parts," to verify that the cables are reconnected in the correct locations.

Assembly Replacement
Rear Panel (Option 1EM)

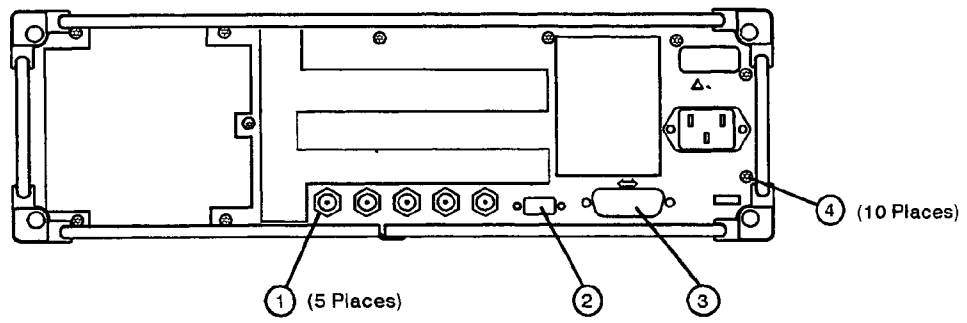

sk778a

Rear Panel (Option 1EM) (2 of 2)

A1 Front Panel Board

Tools Required

- T-10 TORX screwdriver
- 5/16-inch open-end wrench

Removal

1. Remove the front panel assembly. (Refer to "Front Panel" in this chapter.)
2. Remove the small bracket (item 1) that secures W9 (not shown) to the RFI shield (item 2). Disconnect W9.
3. Remove the RFI shield by removing the seven screws (item 3) that secure it.
4. Remove the display (A2) by removing the four screws (item 4) that secure it.
5. Remove the front panel knob (item 5) by pulling it directly away from the front panel.
6. Remove the front panel board (A1) by removing the nine screws (item 6) that secure it.

Replacement

1. Reverse the removal procedure and do the following:
 - Torque all T-10 TORX screws to 9 in-lbs.
 - Torque W9 to 9 in-lbs.

Assembly Replacement
A1 Front Panel Board

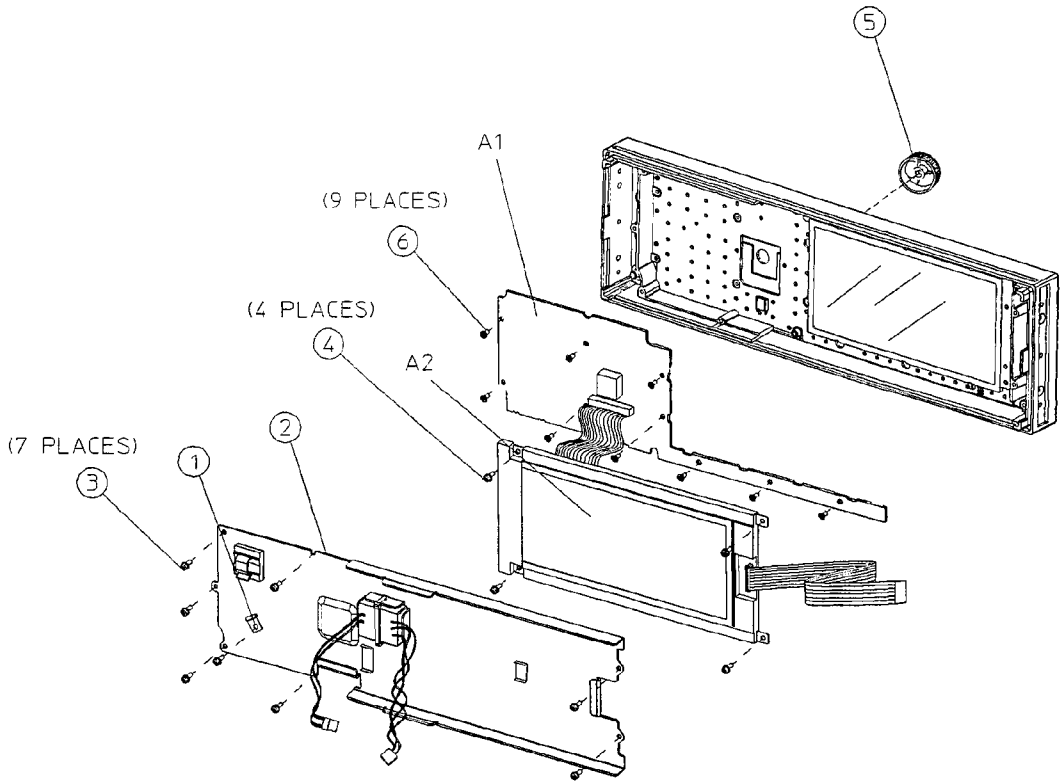

sk747c

A1 Front Panel Board

A2 Display

Tools Required

- T-10 TORX screwdriver
- 5/16-inch open-end wrench

Removal

1. Remove the front panel assembly. (Refer to "Front Panel" in this chapter.)
2. Remove the small bracket (item 1) that secures W9 (not shown) to the RFI shield (item 2). Disconnect W9.
3. Remove the RFI shield by removing the seven screws (item 3) that secure it.
4. Remove the display (A2) by removing the four screws (item 4) that secure it.

Replacement

1. Reverse the removal procedure and do the following:
 - Torque all T-10 TORX screws to 9 in-lbs.
 - Torque W9 to 9 in-lbs.

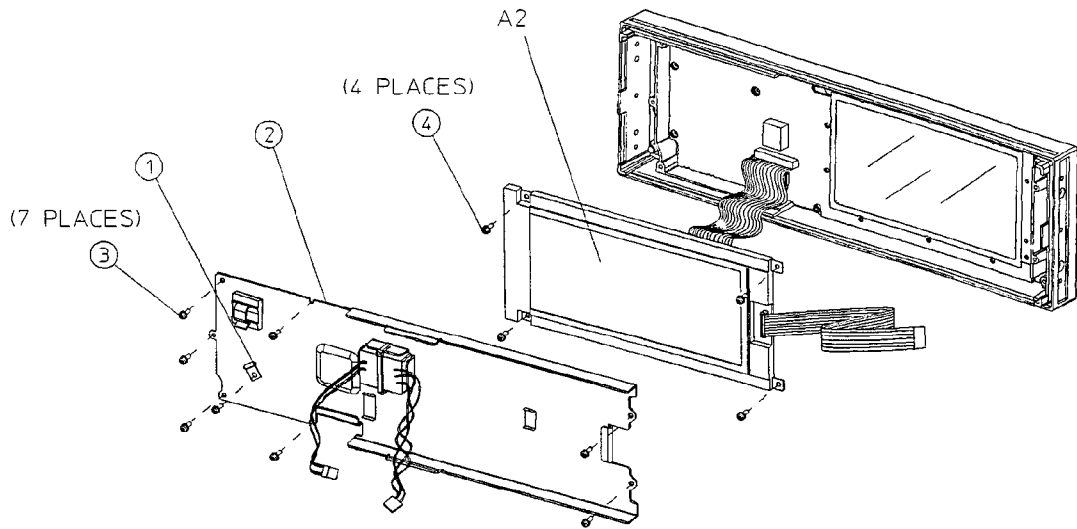

sk746a

A2 Display

A2DS1 Fluorescent Lamp

Tools Required

- Phillips #0 screwdriver

Removal

1. Remove the display (A2). (Refer to "A2 Display" in this chapter.)
2. Loosen the screw (item 1) on the compartment door (item 2) of the display. Remove the door.
3. Remove the fluorescent lamp (A2DS1) from the compartment.

Replacement

1. Reverse the removal procedure. Ensure the lamp is correctly positioned in the reflective paper of the compartment.

Assembly Replacement
A2DS1 Fluorescent Lamp

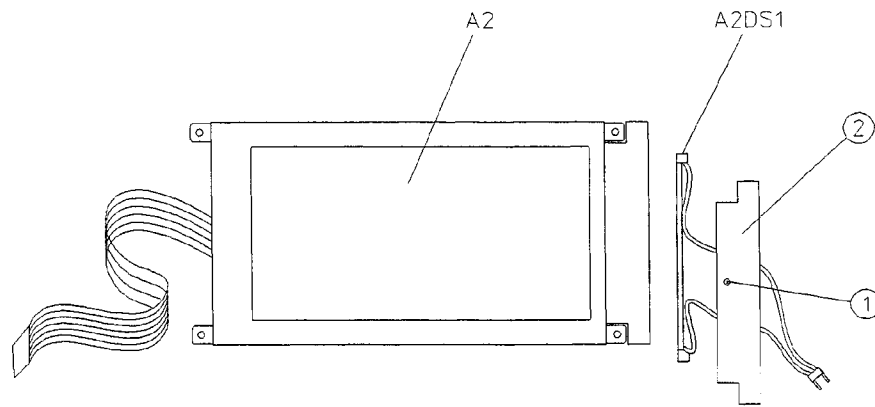

sk744a

A2DS1 Fluorescent Lamp

A3 Inverter

Tools Required

- wire cutters

Removal

NOTE:

It is best to attempt this procedure without removing the front panel assembly. If the front panel assembly is removed, you will be required to perform time-consuming "Power Level Accuracy" verification tests and adjustments.

1. Remove the instrument cover. (Refer to "Instrument Cover" in this chapter.)
2. Disconnect A3W2 from A2DS1W1.
3. Cut the tie wrap (item 1) that secures the inverter (A3) to the RFI shield (item 2).
4. Remove the inverter.

Replacement

1. Reverse the removal procedure and secure the inverter (A3) with a new tie wrap.

Assembly Replacement
A3 Inverter

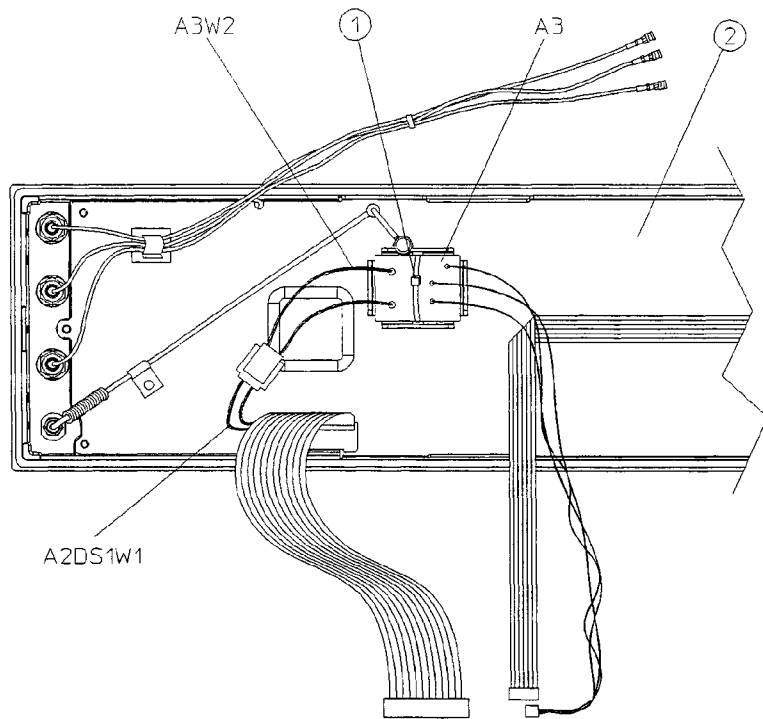

sk749a

A3 Inverter

A4 Power Supply

Tools Required

- T-10 TORX screwdriver
- T-15 TORX screwdriver

Removal

1. Remove the rear panel assembly. (Refer to "Rear Panel" in this chapter.)
2. Remove the screw (item 1) that attaches the motherboard (A14) to the bottom of the power supply shield (item 2).

NOTE: Before proceeding to the next step ensure that the instrument is fully supported on a flat surface. This will keep the front panel assembly stable during the time it is attached only to the right side of the instrument.

Assembly Replacement
A4 Power Supply

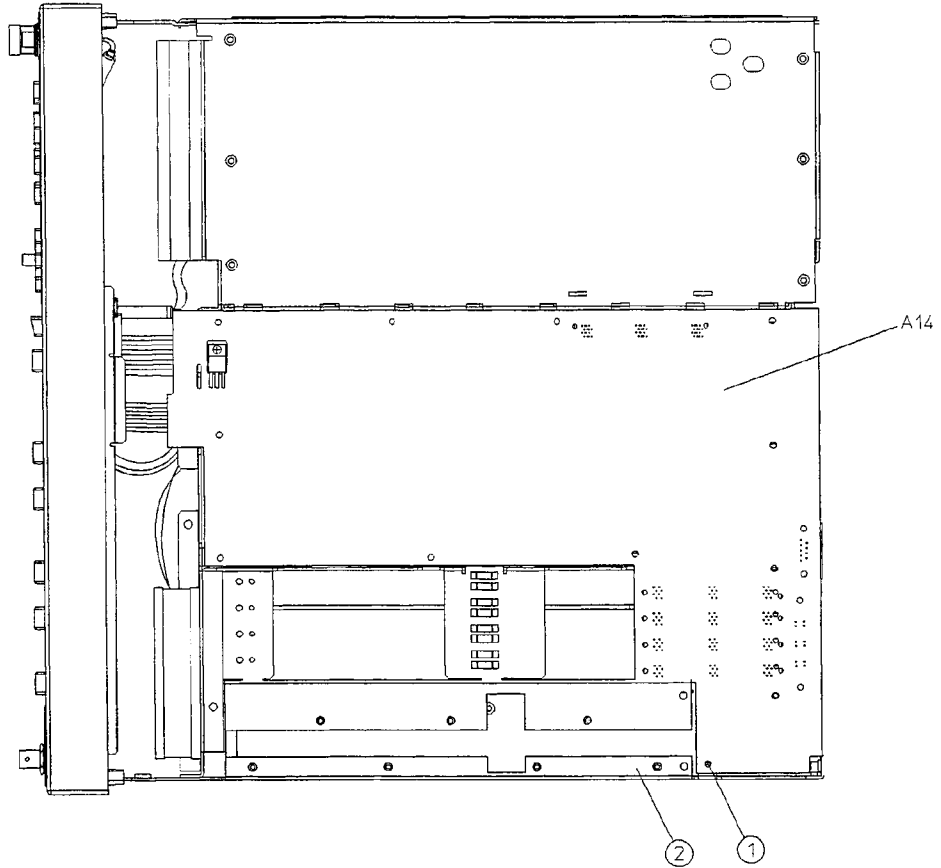

sk7101a

A4 Power Supply (1 of 2)

Assembly Replacement

A4 Power Supply

3. Disconnect A4W1 from the motherboard (A14).
4. Carefully peel off the side trim (item 3) from the left side of the front panel assembly (item 4).
5. Remove the two screws (item 5) that attach the power supply shield (item 2) to the front panel assembly.
6. Remove the five screws (item 6) that attach the power supply shield to the instrument chassis (item 7).
7. Lift the rear of the power supply shield one-quarter inch and then pull it away from the instrument chassis.

NOTE: While removing the power supply shield try to limit the movement of the front panel assembly. This will reduce the stress on W9.

8. Remove the 12 screws (item 8) that attach the power supply to the power supply shield.
9. Remove the power supply (A4) from the front end of the shield.

Replacement

1. Reverse the removal procedure and do the following:
 - Torque all T-10 TORX screws to 9 in-lbs.
 - Torque all T-15 TORX screws to 21 in-lbs.

Assembly Replacement
A4 Power Supply

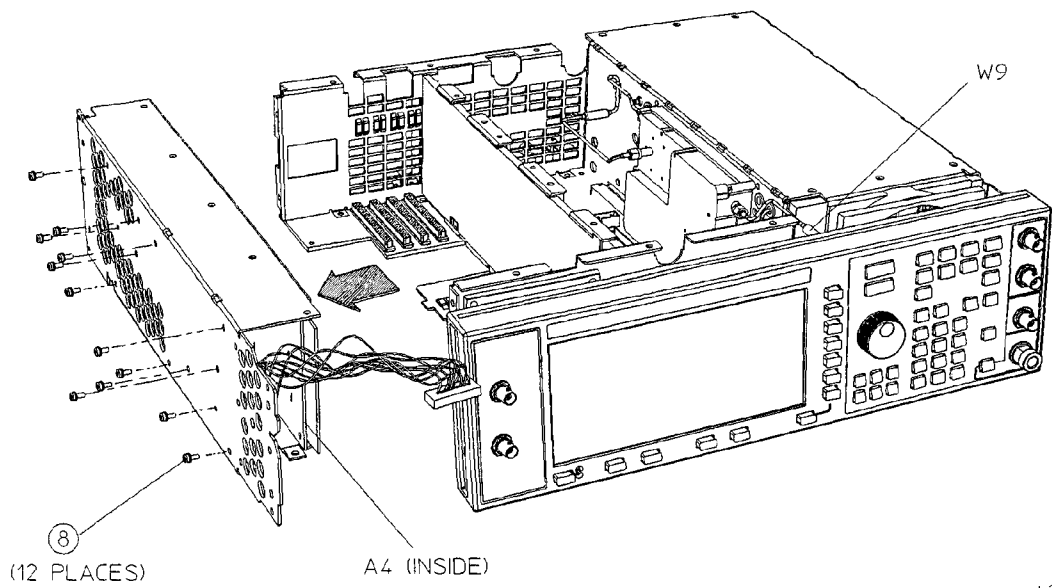
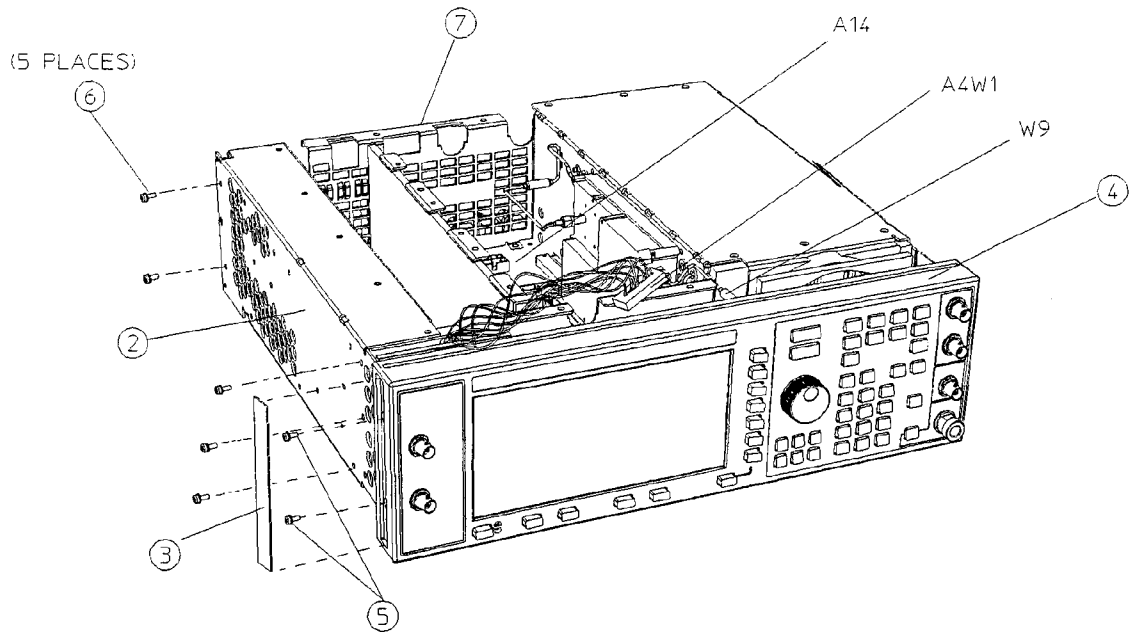

sk7100a

A4 Power Supply (2 of 2)

A4 Power Supply (Option 1EM)

Tools Required

- T-10 TORX screwdriver

Removal

1. Remove the front panel assembly. (Refer to "Front Panel (Option 1EM)" in this chapter.)
2. Remove the bottom cover by removing the 15 screws that secure it.
3. Remove the screw (item 1) that attaches the motherboard (A14) to the bottom of the power supply shield (item 2).
4. Disconnect A16W1 from the power supply (A4).
5. Remove the two screws (item 3) that attach the line module (A16) to the rear panel.
6. Remove the line module and A16W1 from the opening in the rear panel. The line module will remain connected to the rear panel, however, via the ground wire, A16W2. (Refer to the figure on page 37 of this chapter.)
7. Remove the three screws (item 4) that attach the rear panel to the power supply shield.

Assembly Replacement
A4 Power Supply (Option 1EM)

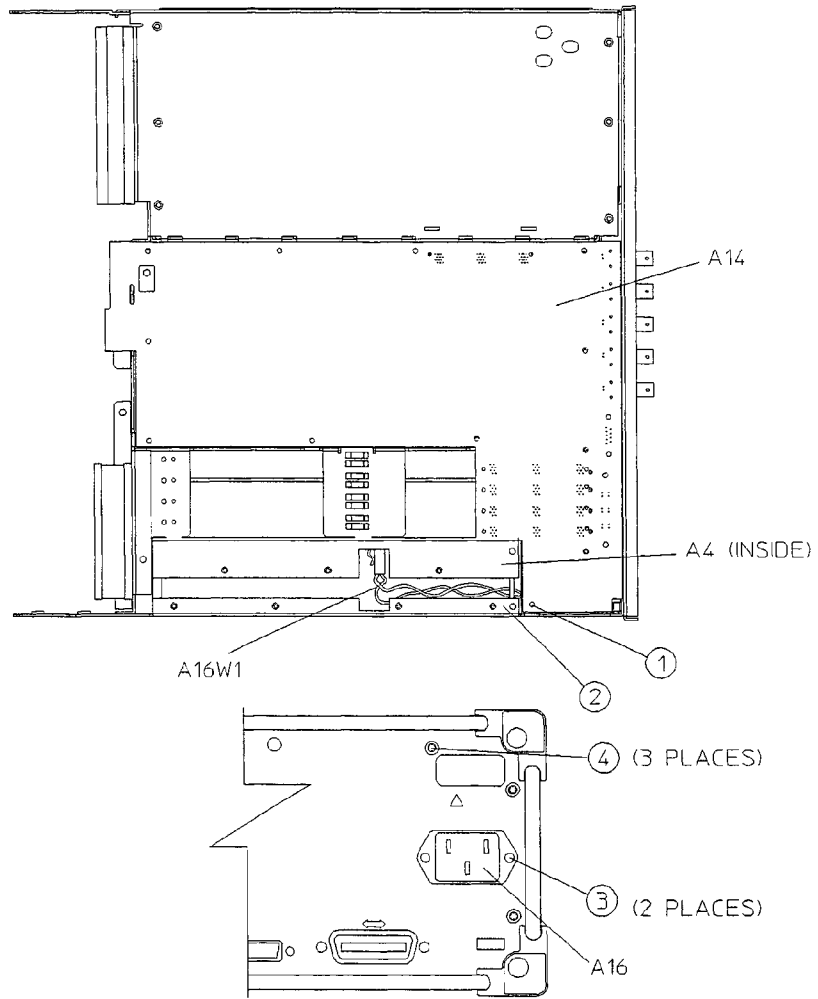

sk724a

A4 Power Supply (Option 1EM) (1 of 2)

Assembly Replacement
A4 Power Supply (Option 1EM)

8. Disconnect A4W1 from the motherboard (A14).
9. Remove the five screws (item 5) that attach the power supply shield (item 2) to the instrument chassis (item 6).
10. Pull the power supply shield away from the instrument chassis.
11. Remove the 12 screws (item 7) that attach the power supply to the power supply shield.
12. Remove the power supply (A4) from the front end of the shield.

Replacement

1. Reverse the removal procedure and torque all T-10 TORX screws to 9 in-lbs.

Assembly Replacement
A4 Power Supply (Option 1EM)

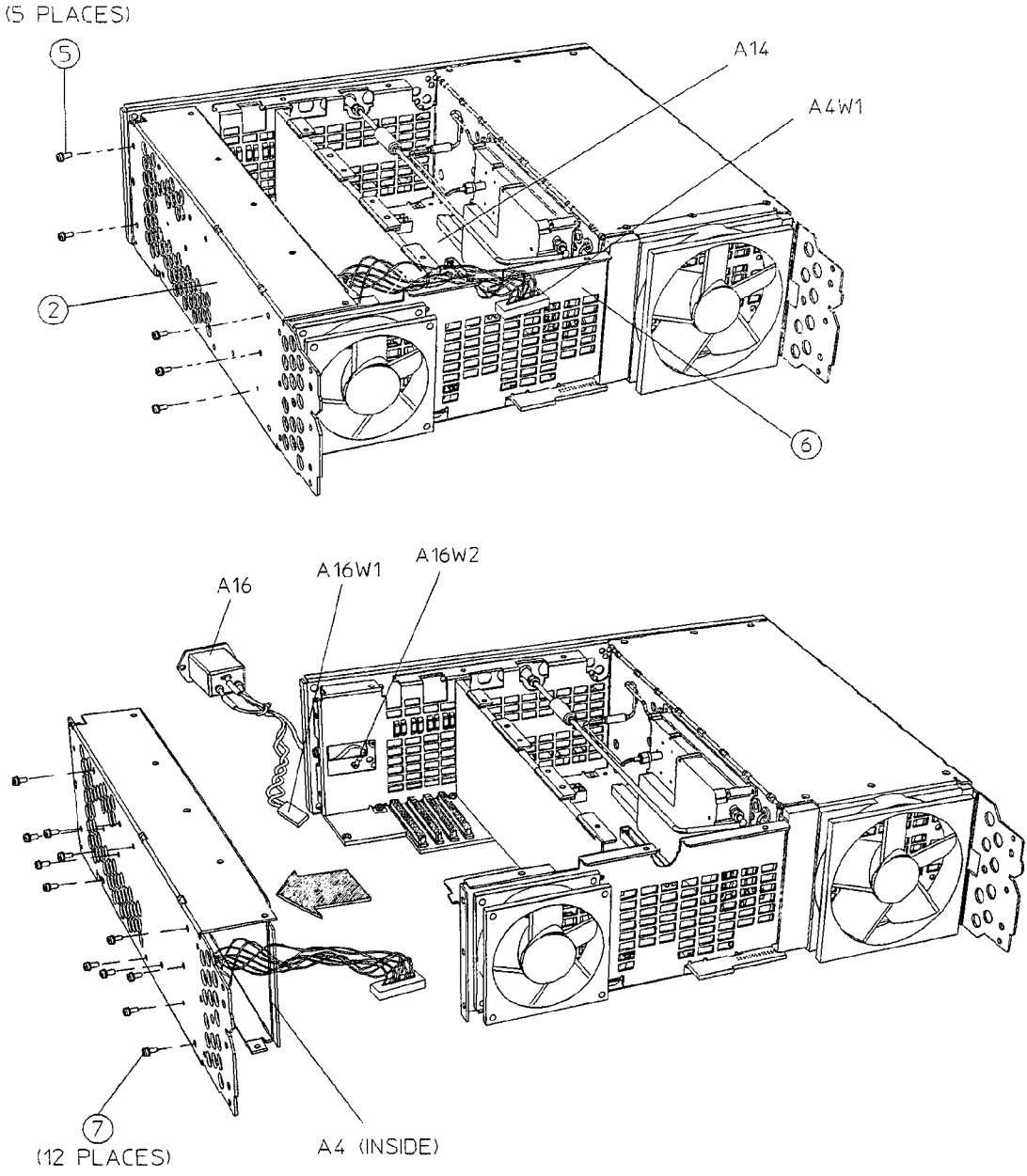

sk723o

A4 Power Supply (Option 1EM) (2 of 2)

A7 Baseband Generator Board (Option 1EH)

Tools Required

- T-10 TORX screwdriver
- long nose pliers

Removal

1. Remove the instrument cover. (Refer to "Instrument Cover" in this chapter.)
2. Remove the top cover by removing the 11 screws that secure it.
3. Disconnect W3, W4, W5, W15, W16, W17, and A17W1 from the baseband generator board (A7).
4. Pull up on the baseband generator board to remove it from the motherboard connector.

Replacement

1. Reverse the removal procedure and do the following:
 - Refer to Chapter 3, "Replaceable Parts," to verify that the cables are reconnected in the correct locations.
 - Torque all T-10 TORX screws to 9 in-lbs.

Assembly Replacement
A7 Baseband Generator Board (Option 1EH)

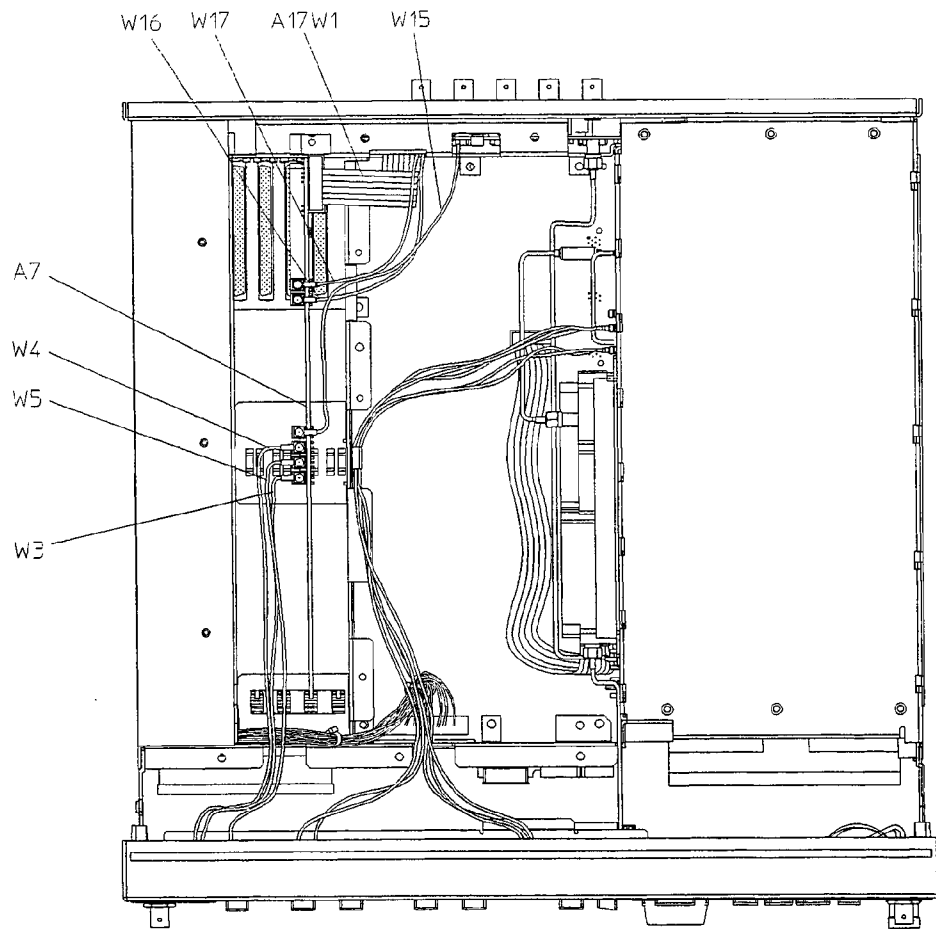

sk735a

A7 Baseband Generator Board (Option 1EH)

A7 Baseband Generator Board (Options UN3 & UN4)

Tools Required

- T-10 TORX screwdriver
- long nose pliers

Removal

1. Remove the instrument cover. (Refer to "Instrument Cover" in this chapter.)
2. Remove the top cover by removing the 11 screws that secure it.
3. Disconnect W15, W16, W17, and W19 from the baseband generator board (A7)..
4. Pull up on the baseband generator board to remove it from the motherboard connector.

Replacement

1. Reverse the removal procedure and do the following:
 - Refer to Chapter 3, "Replaceable Parts," to verify that the cables are reconnected in the correct locations.
 - Torque all T-10 TORX screws to 9 in-lbs.

Assembly Replacement
A7 Baseband Generator Board (Options UN3 & UN4)

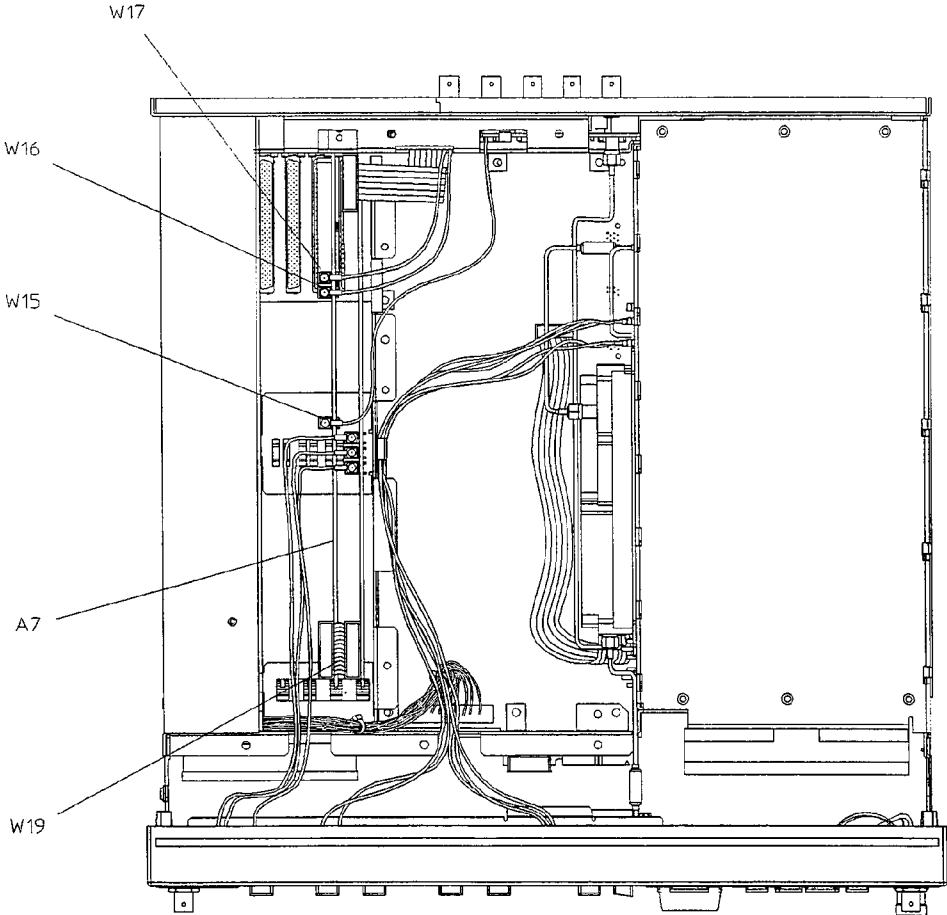

sk7136a

A7 Baseband Generator Board (Options UN3 & UN4)

A8 Data Generator Board (Options UN3 & UN4)

Tools Required

- T-10 TORX screwdriver
- long nose pliers

Removal

1. Remove the instrument cover. (Refer to "Instrument Cover" in this chapter.)
2. Remove the top cover by removing the 11 screws that secure it.
3. Disconnect A17W1, W3, W4, W5 , and W19 from the data generator board (A8).
4. Pull up on the data generator board to remove it from the motherboard connector.

Replacement

1. Reverse the removal procedure and do the following:
 - Refer to Chapter 3, "Replaceable Parts," to verify that the cables are reconnected in the correct locations.
 - Torque all T-10 TORX screws to 9 in-lbs.

Assembly Replacement
A8 Data Generator Board (Options UN3 & UN4)

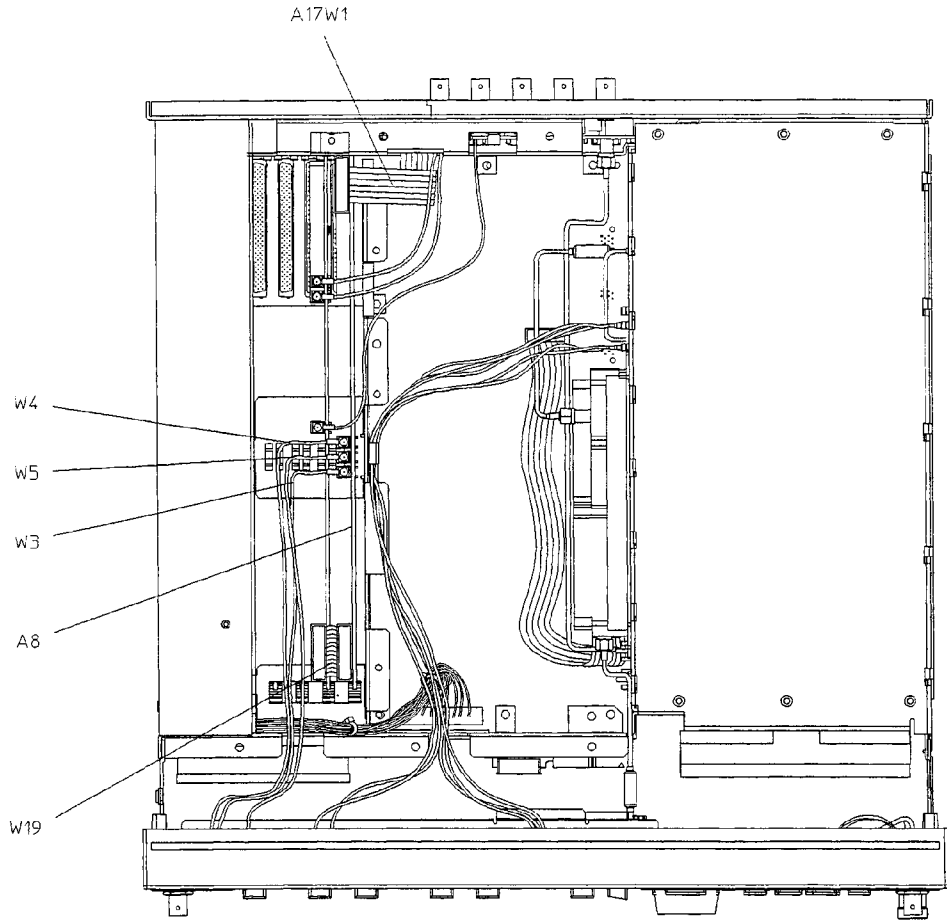

sk7138a

A8 Data Generator Board (Option UN3 & UN4)

A9, A11, and A12 Daughterboard Card Cage Boards

Use this procedure to remove any one of the following assemblies:

- Output Board (A9)
- Reference Board (A11)
- Synthesizer/Doubler Board (A12)

Tools Required

- T-8 TORX screwdriver

Removal

1. Remove the instrument cover. (Refer to "Instrument Cover" in this chapter.)
2. Remove the right-side cover by removing the four screws that attach it to the instrument chassis.
3. Simultaneously lift the left and right extractors (item 1) on the board you want to remove.
4. Remove the board from the card cage slot.

Replacement

1. Reverse the removal procedure and torque all T-8 TORX screws to 9 in-lbs.

Assembly Replacement
A9, A11, and A12 Daughterboard Card Cage Boards

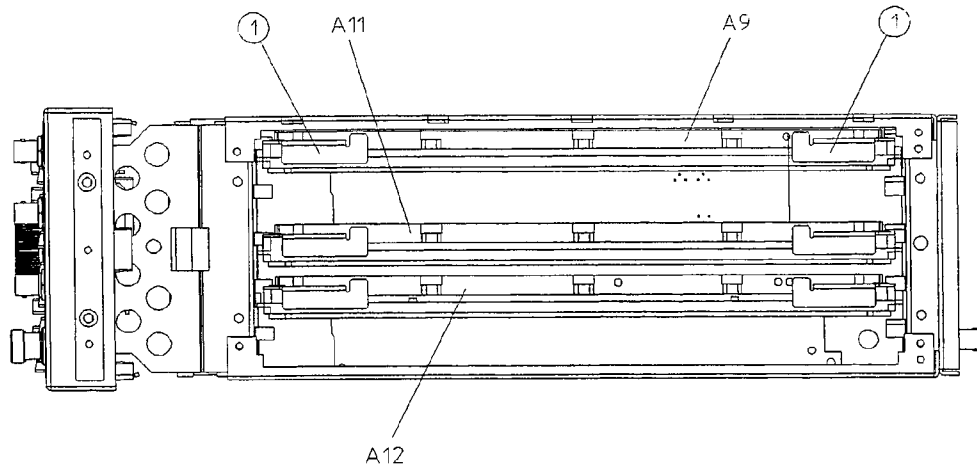

sk742a

A9, A11, and A12 Daughterboard Card Cage Boards

A14 CPU/Motherboard

Tools Required

- T-10 TORX screwdriver

Removal

1. Remove the rear panel assembly. (Refer to "Rear Panel" in this chapter.)
2. If you have Option UN3 or UN4, remove the baseband generator board (A7) and the data generator board (A8). (Refer to "A7 Baseband Generator Board (Options UN3 & UN4)" and "A8 Data Generator Board (Options UN3 & UN4)" in this chapter.)

If you have Option 1EH, remove the baseband generator board (A7). (Refer to "A7 Baseband Generator Board (Option 1EH)" in this chapter.)

NOTE: The figure on the adjacent page represents an Option UN3 or UN4. Option 1EH is not shown.

3. Disconnect A1W1, A3W1, W10, B1W1, and B2W1 from the motherboard (A14).
4. Disconnect W13 and A4W1 from the motherboard.

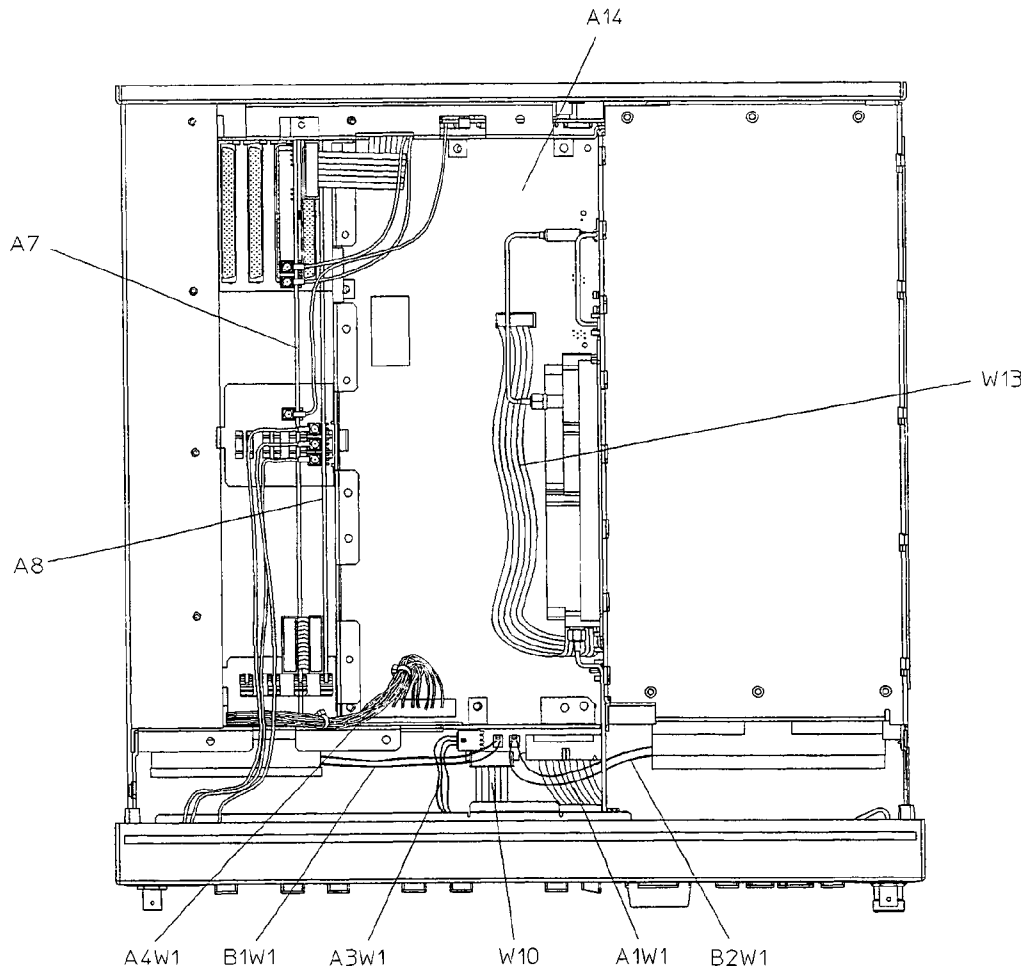

sk7137a

A14 CPU/Motherboard (1 of 2)

Assembly Replacement
A14 CPU/Motherboard

5. Turn the signal generator upside-down and remove the screw (item 1) from the motherboard (A14).
6. Remove the screw (item 2) that secures the transistor on the motherboard to the instrument chassis.

NOTE: The transistor screw is installed with an insulative bushing. Be careful not to lose it when removing the screw.

7. Remove the motherboard.

Replacement

1. Reverse the removal procedure and do the following:
 - When reinstalling the motherboard, remember to insert the tab and daughterboard connector into the corresponding slots of the instrument chassis before securing it with the screws.
 - Torque the two T-10 TORX screws to 9 in-lbs.
 - Refer to Chapter 3, "Replaceable Parts," to verify that the cables are reconnected in the correct locations.

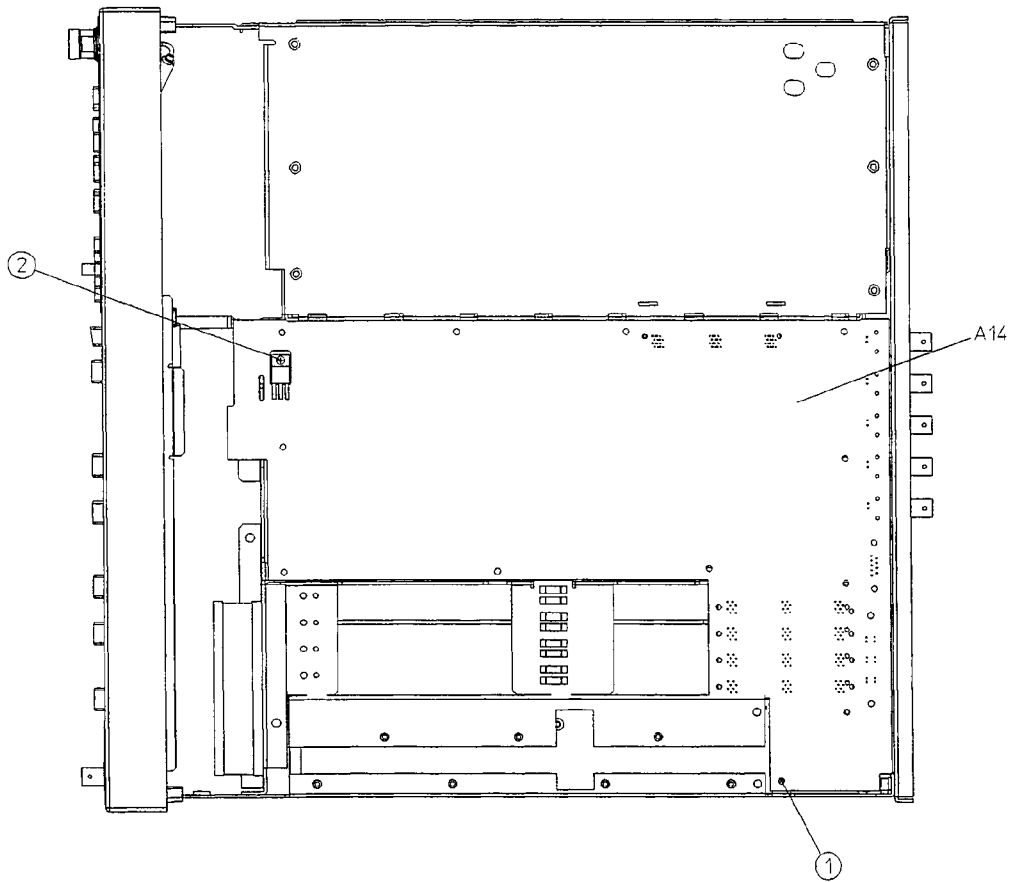

sk799a

A14 CPU/Motherboard (2 of 2)

A14BT1 Battery

Tools Required

- T-10 TORX screwdriver
- soldering tools
- exacto knife
- Dow Corning 3145 RTV Clear Adhesive Sealant (HP part number 0470-0450)

Removal

1. Remove the instrument cover. (Refer to "Instrument Cover" in this chapter.)
2. Remove the top cover by removing the 11 screws that secure it.
3. Remove the bottom cover by removing the 15 screws that secure it.
4. Unsolder the leads of the battery (A14BT1) from the motherboard (A14).

CAUTION: Calibration data will be preserved with the removal of the battery. However, user data will be lost unless it is saved and later restored using an external controller.

5. The battery is also attached to the motherboard with a silicon adhesive. Using an exacto knife, *carefully* cut through the adhesive to lift and remove the battery from the motherboard.

WARNING: Battery A14BT1 contains lithium. Do not incinerate or puncture this battery. Dispose of the discharged battery in a safe manner. Refer to Chapter 9, "Safety and Regulatory," for instructions on how to dispose of the battery.

6. Remove any excess adhesive from the motherboard surface.

Replacement

1. Apply a small amount of silicon adhesive to the battery's location on the motherboard.
2. Insert the new battery into the motherboard making sure it is oriented with the correct polarity.
3. Solder the battery's leads to the motherboard.
4. Reassemble the instrument.

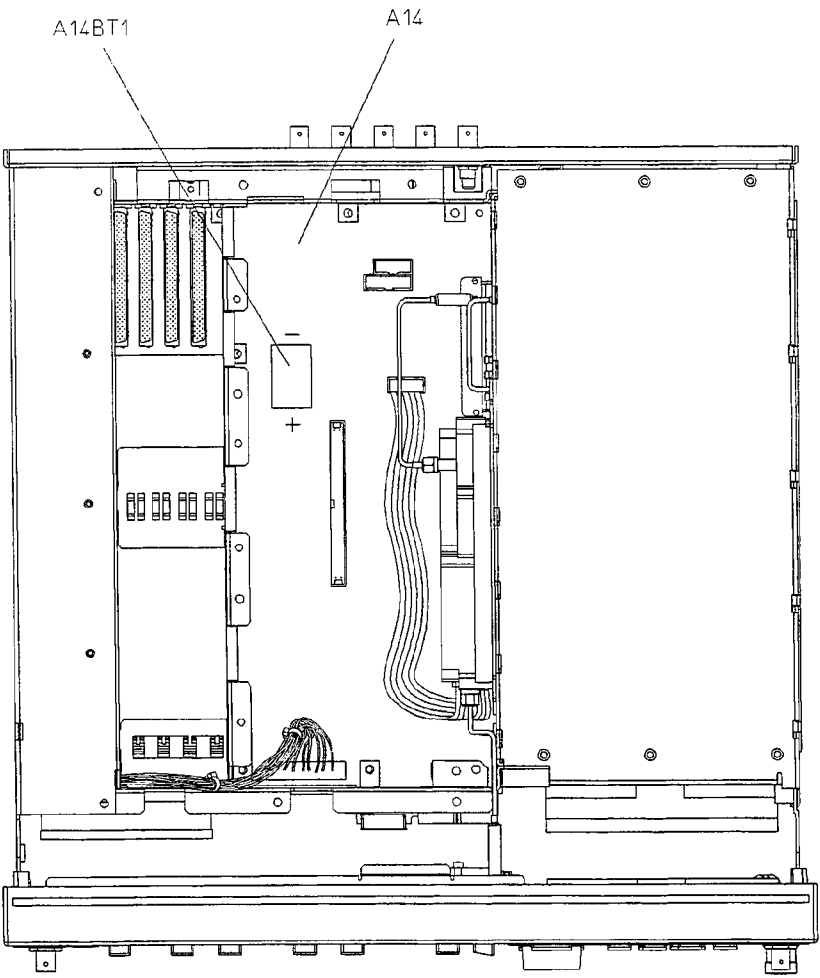

sk798a

A14BT1 Battery

A15 Daughterboard

Tools Required

- T-8 TORX screwdriver
- T-10 TORX screwdriver
- long nose pliers

Removal

1. Remove the instrument cover. (Refer to "Instrument Cover" in this chapter.)
2. Remove the top cover by removing the 11 screws that secure it.
3. Disconnect W1, W2, W6, W7, and W8 from the daughterboard (A15).
4. Remove the right-side cover (not shown) by first removing the four screws that attach it to the instrument chassis. Then push down on the cover while sliding it towards the front of the instrument to unhook its tabs from the slots on the top of the chassis.

Assembly Replacement
A15 Daughterboard

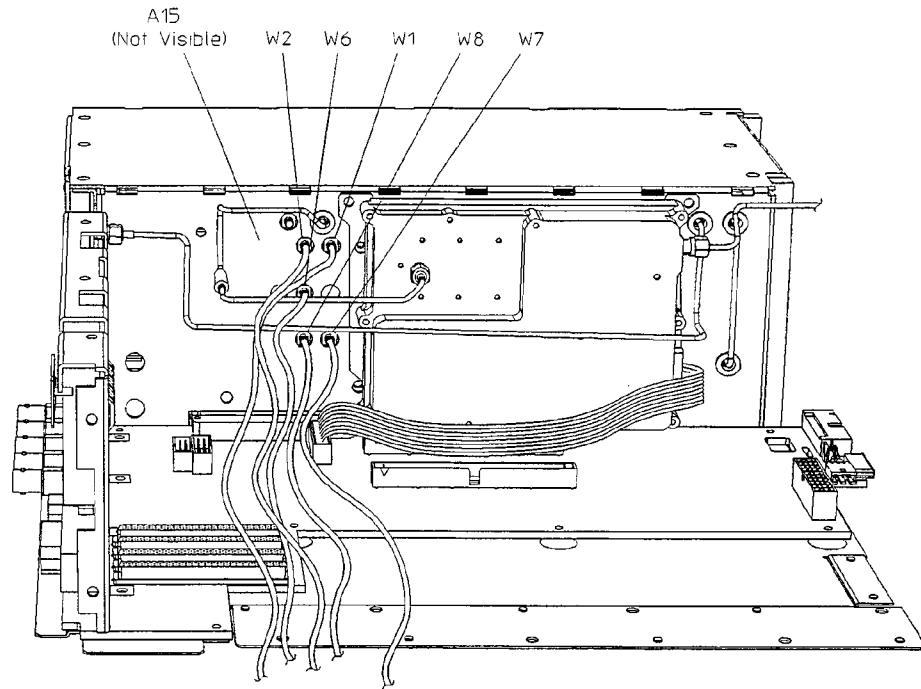

sk738a

A15 Daughterboard (1 of 2)

Assembly Replacement

A15 Daughterboard

5. Simultaneously lift the left and right extractors (item 1) on the output board (A9).
6. Remove the output board from the card cage slot.
7. Repeat steps 5 and 6 for the reference board (A11) and the synthesizer/doubler board (A12).
8. Remove the five screws (item 2) that attach the daughterboard (A15) to instrument chassis.
9. Remove the daughterboard.

Replacement

1. Reverse the removal procedure and do the following:
 - Torque all T-8 TORX screws to 9 in-lbs.
 - Torque all T-10 TORX screws to 9 in-lbs.
 - Refer to Chapter 3, "Replaceable Parts," to verify that the cables are reconnected in the correct locations.

Assembly Replacement
A15 Daughterboard

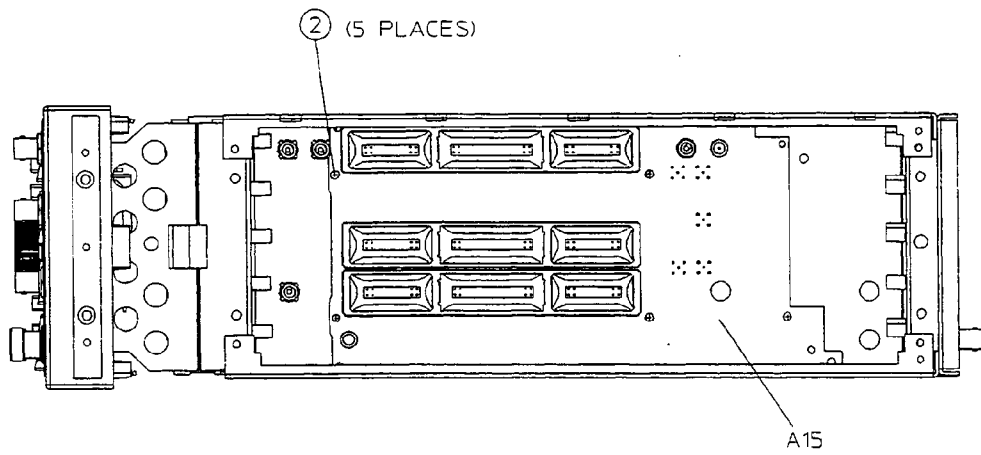
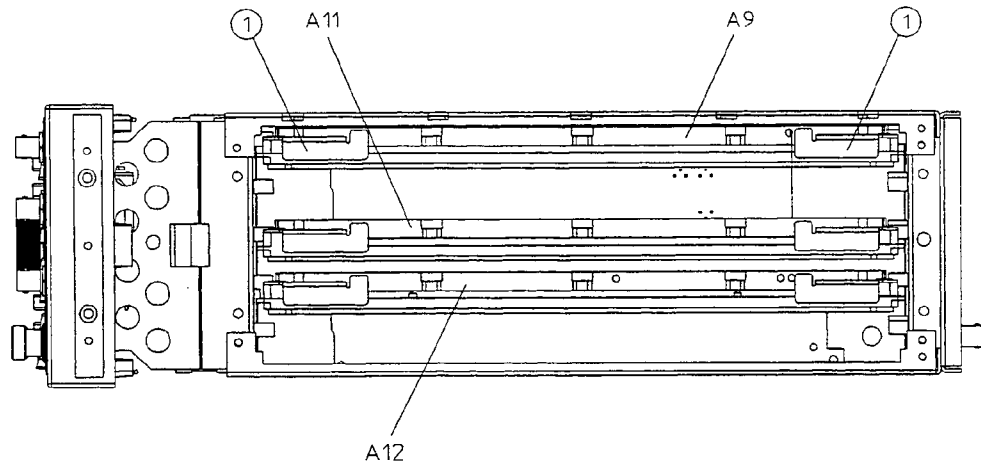

sk7143a

A15 Daughterboard (2 of 2)

A16 Line Module

Tools Required

- T-10 TORX screwdriver
- 5.5-mm wrench or nut driver

Removal

1. Remove the rear panel assembly. (Refer to "Rear Panel" in this chapter.)
2. Remove the nut (item 1) that attaches the line module's ground wire (A16W2) to the inside of rear panel.
3. Remove the two screws (item 2) that attach the line module (A16) to the rear panel.
4. Remove the line module from the opening in the rear panel.

Replacement

1. Reverse the removal procedure and do the following:
 - Torque the 5.5-mm nut that attaches the ground wire to the rear panel to 9 in-lbs.
 - Torque all T-10 TORX screws to 9 in-lbs.

Assembly Replacement
A16 Line Module

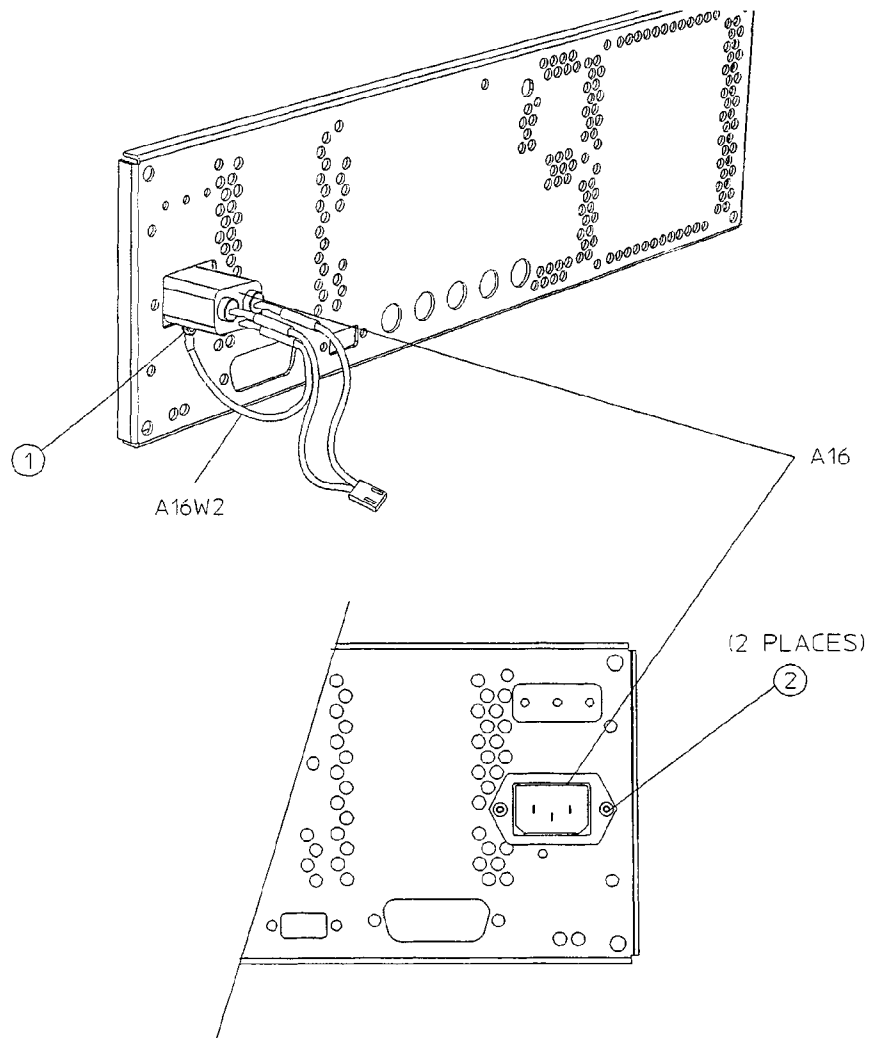

sk739a

A16 Line Module

A17 Rear Panel Interface Board (Options 1EH, UN3, UN4)

Tools Required

- 5/8-inch wrench or nut driver
- 1/4-inch wrench or nut driver (Option 1EM)

Removal

1. Remove the rear panel assembly. (Refer to "Rear Panel" in this chapter.)
2. Remove the nuts (item 1) and washers (item 2) on the eight BNC connectors of the rear panel.
If you have Option 1EM, remove the nuts (item 3) and washers (item 4) on eight of the associated SMB connectors on the rear panel.
3. Remove the rear panel interface board (A17) from the rear panel.

Replacement

1. Reverse the removal procedure and do the following:
 - Torque the 5/8-inch BNC nuts to 21 in-lbs.
 - If you have Option 1EM, torque the 1/4-inch SMB nuts to 14 in-lbs.

Assembly Replacement
A17 Rear Panel Interface Board (Options 1EH, UN3, UN4)

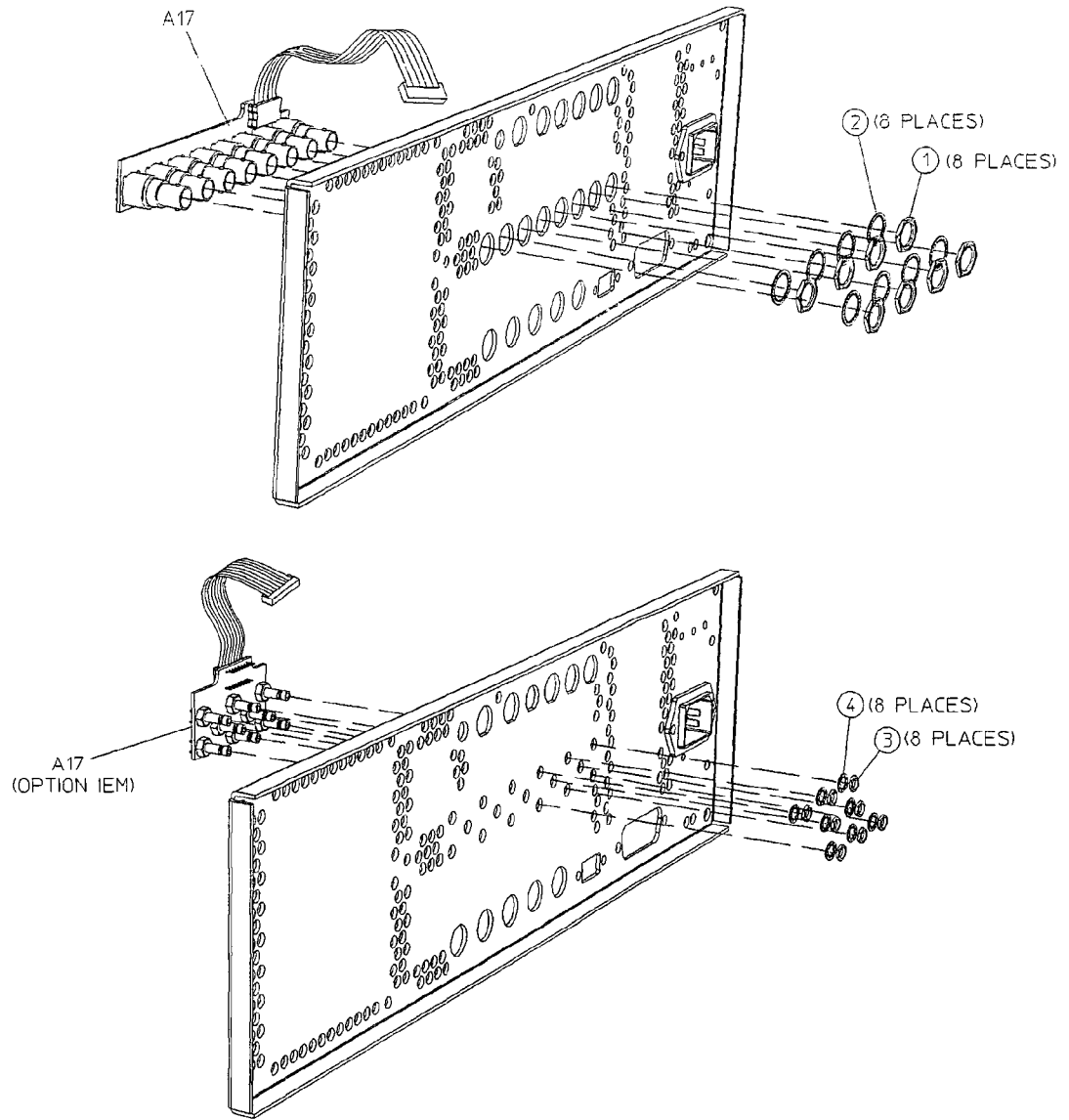

sk728a

A17 Rear Panel Interface Board (Options 1EH, UN3, UN4)

AT1 Electronic Attenuator/RPP

Tools Required

- T-10 TORX screwdriver
- 5/16-inch open-end wrench

Removal

1. Remove the instrument cover. (Refer to "Instrument Cover" in this chapter.)
2. Remove the top cover by removing the 11 screws that secure it.
3. Disconnect W9, W13, and W14 from the electronic attenuator/RPP (AT1).
4. Remove the two screws (item 1) that attach the attenuator/RPP to the instrument chassis.
5. Tilt the attenuator/RPP away from the chassis wall, then carefully lift it out of the instrument.

There are two hinged tabs at the bottom of the attenuator/RPP which fit into slots in the instrument chassis. Therefore, it is necessary to tilt the attenuator/RPP away from the chassis wall so that the tabs can be guided out of the slots.

Replacement

1. Reverse the removal procedure and do the following:
 - When reinstalling the electronic attenuator/RPP (AT1), remember to insert its hinged tabs into the slots located at the base of the chassis wall on which the attenuator/RPP will be mounted.
 - Torque W9 and W14 to 9 in-lbs.
 - Torque the two T-10 TORX screws to 9 in-lbs.

Assembly Replacement
AT1 Electronic Attenuator/RPP

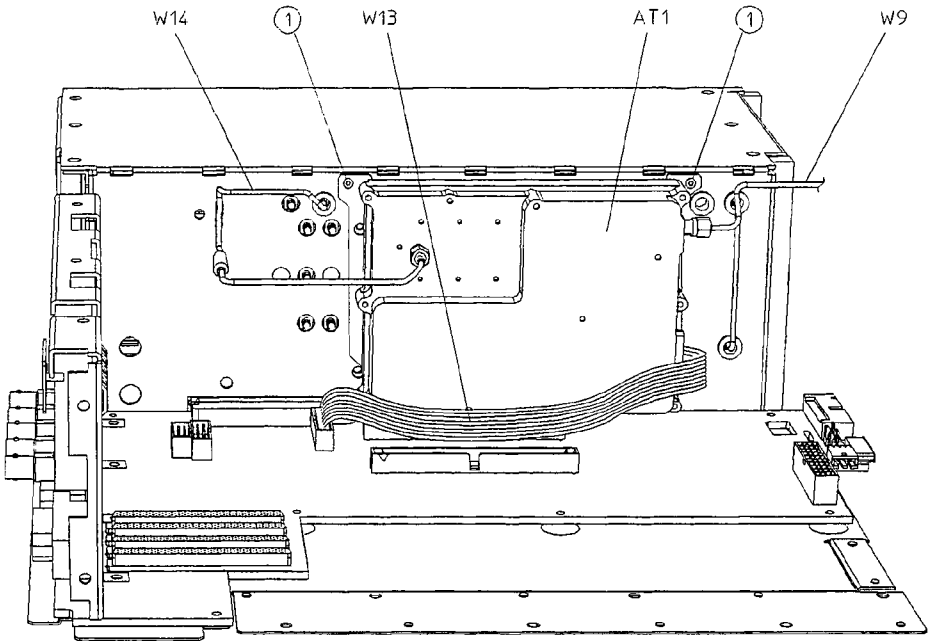

sk732a

AT1 Electronic Attenuator/RPP

B1 Small Fan Assembly

Tools Required

- knife blade (or equivalent)
- long nose pliers

Removal

NOTE: It is best to attempt this procedure without removing the front panel assembly. If the front panel assembly is removed, you will be required to perform time-consuming "Power Level Accuracy" verification tests and adjustments.

1. Remove the instrument cover. (Refer to "Instrument Cover" in this chapter.)
2. Disconnect B1W1 from the motherboard (A14).
3. Remove the four plastic rivets (item 1) that attach the fan assembly (B1) to the instrument chassis. Use a knife blade (or equivalent) to pry up the head of the plunger portion of the rivet. Once the head of the plunger is adequately raised, use a pair of long nose pliers to remove the rivet. *Be careful not to damage the rivets with the blade.*

NOTE: The plastic rivets consist of two pieces: a plunger and a sheath. Ensure both parts are removed.

4. Remove the fan assembly.

Replacement

1. Reverse the removal procedure. When reinserting the plastic rivets, the sheath must be fully seated in the fan assembly before the plunger can be depressed.

Assembly Replacement
B1 Small Fan Assembly

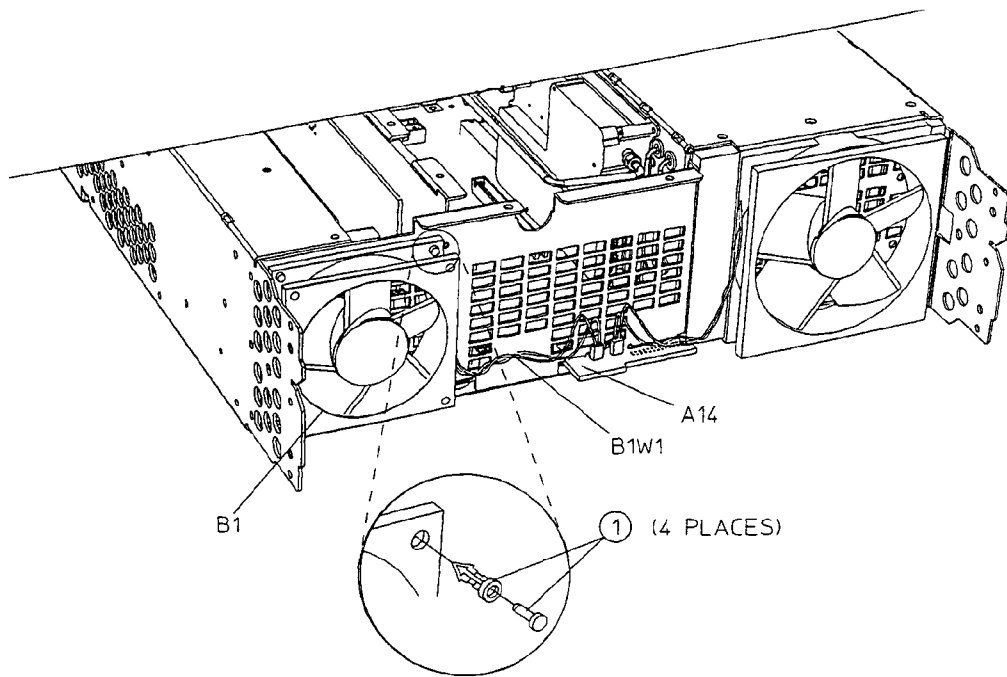

sk727a

B1 Small Fan Assembly

B2 Large Fan Assembly

Tools Required

- 1/4-inch open-end wrench
- *Modified* T-10 TORX bit (HP part number 8710-1637)

Bit Modification. The hexagonal head at the end of the TORX bit must be removed so that the total length of the bit is approximately 1.5 inches (see figure below). A hexagonal portion of the bit will remain for use with a wrench. The shortened bit will now fit between the fan assembly and the front panel assembly.

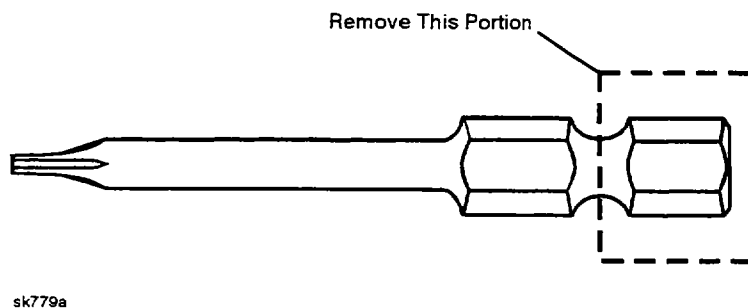

Removal

NOTE: It is best to attempt this procedure without removing the front panel assembly. If the front panel assembly is removed, you will be required to perform time-consuming "Power Level Accuracy" verification tests and adjustments.

1. Remove the instrument cover. (Refer to "Instrument Cover" in this chapter.)
2. Disconnect B2W1 from the motherboard (A14).
3. Remove the four screws (item 1) that attach the fan assembly (B2) to the instrument chassis.
4. Remove the fan assembly.

Replacement

1. Reverse the removal procedure and torque the T-10 TORX screws to 9 in-lbs.

Assembly Replacement
B2 Large Fan Assembly

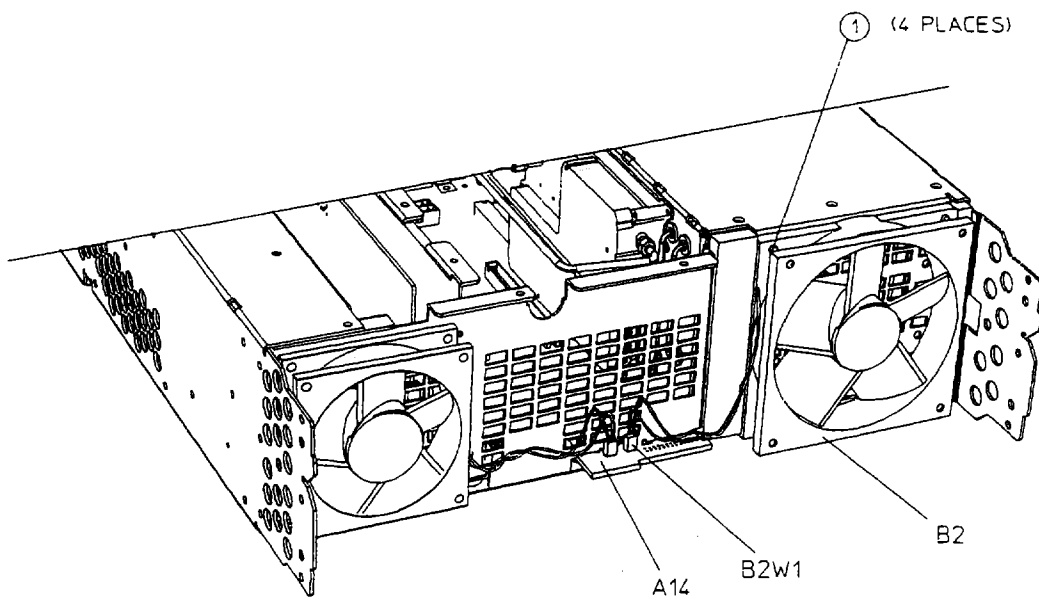

sk726a

B2 Large Fan Assembly

W11, W12, and W14 Semi-Rigid Cables

Tools Required

- MILBAR 2R snap-ring pliers (used to remove snap rings from cable retainers)
- 5/16-inch open-end wrench

Removal

1. Remove all the daughterboard card cage boards to allow access to the instrument chassis cable connections. (Refer to "A9, A11, and A12 Daughterboard Card Cage Boards" in this chapter.)
2. Remove the snap ring (item 1) from the cable retainer (item 2) of the cable you want to remove. The cable is now disconnected from the instrument chassis (item 3).
3. Disconnect the other end of the cable.

Replacement

1. If you're installing a new cable, a *new* cable retainer (item 2) must first be attached to the end of the cable (item 4). Verify the cable retainer is correctly attached by listening for an audible "click" as you slide it over the end of the cable.
2. Insert the cable-retainer end of the cable assembly into the opening of the instrument chassis and then secure it with a snap ring.
3. Connect the other end of the cable. All semi-rigid cables should be torqued to 9 in-lbs.
4. Replace the daughterboard card cage boards.

Assembly Replacement
W11, W12, and W14 Semi-Rigid Cables

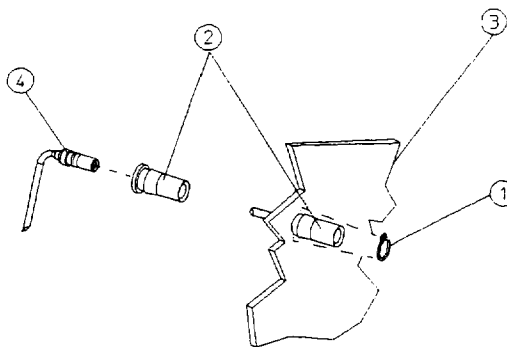
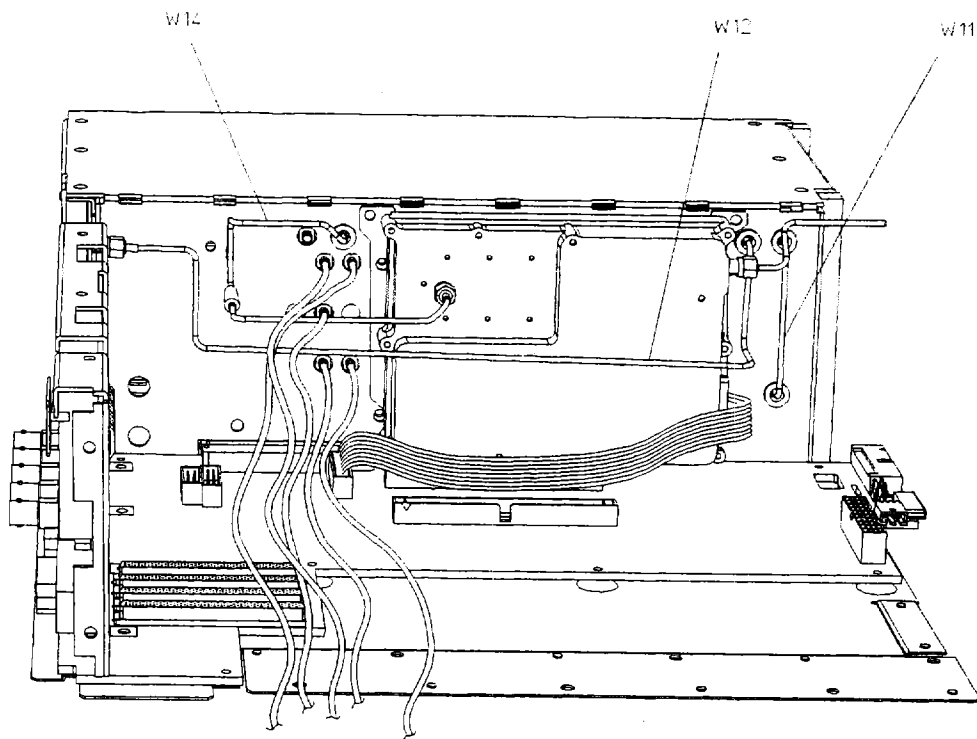

sk753a

W11, W12, and W14 Semi-Rigid Cables

Assembly Replacement
W11, W12, and W14 Semi-Rigid Cables



5 Post-Repair Procedures

This chapter lists the performance tests and adjustments that must be performed after an assembly has been replaced.

Performance Tests

The following matrix shows you which performance tests must be performed when a specific assembly is repaired or replaced. Except where noted, all tests are automated using software. Refer to the "HP ESG-D Series Signal Generators Calibration Guide" for more information on performance tests.

Performance Tests

Performance Tests	Repaired/Replaced Assembly															
	A1 Front Panel Bd	A2 Display	A2DS1 Lamp	A3 Inverter	A4 Power Supply	A7 Baseband Gen Bd	A8 Data Gen Bd	A9 Output Bd	A11 Reference Bd	A12 Synthesizer Bd	A14 Motherboard	A14BT1 Battery	A15 Daughterboard	A16 Line Module	A17 Rear Panel Bd	AT1 Attenuator
AM Frequency Response					●			●	●		●		●			
Burst Modulation On/Off Ratio					●			●	●		●		●			
DCFM Frequency Offset					●				●	●	●	●	●			
Digital Mod: Power Level Accuracy					●			●			●		●			
FM Frequency Response					●				●	●	●		●			
Harmonics					●			●		●	●		●			●
Internal AM Accuracy					●			●	●		●		●			
Internal AM Distortion					●			●	●		●		●			
Internal FM Accuracy					●				●	●	●		●			
Internal FM Distortion					●				●	●	●		●			
Nonharmonics					●	●	●	●	●	●	●		●			
Phase Modulation Accuracy					●				●	●	●		●			
Phase Modulation Distortion					●				●	●	●		●			
PM Frequency Response					●				●	●	●		●			
Power Level Accuracy	● ¹	● ¹	● ¹	● ¹	●			●			●		●	● ²	● ²	●
Pulse Modulation On/Off Ratio					●			●			●		●			
Residual FM					●				●	●	●		●			
Subharmonics					●			●		●	●		●			
Timebase Aging Rate ³					●				●		●		●			

Performance Tests

Performance Tests	Repaired/Replaced Assembly															
	A1 Front Panel Bd	A2 Display	A2DS1 Lamp	A3 Inverter	A4 Power Supply	A7 Baseband Gen Bd	A8 Data Gen Bd	A9 Output Bd	A11 Reference Bd	A12 Synthesizer Bd	A14 Motherboard	A14BT1 Battery	A15 Daughterboard	A16 Line Module	A17 Rear Panel Bd	AT1 Attenuator
Modulation Source Frequency Accuracy ³					●						●		●			
Digital Mod: Internal IQ Quality					●	●	●	●		●	●		●			●

1. Perform this test only if you *do not* have Option 1EM.
2. Perform this test only if you have Option 1EM.
3. This test must be performed manually.

Adjustments

The following matrix shows you which adjustments must be performed when a specific assembly is repaired or replaced. Except where noted, all adjustments are automated using software. Refer to the "HP ESG-D Series Signal Generators Calibration Guide" for more information on adjustments.

Adjustments

Adjustments	Repaired/Replaced Assembly															
	A1 Front Panel Bd	A2 Display	A2DS1 Lamp	A3 Inverter	A4 Power Supply	A7 Baseband Gen Bd	A8 Data Gen Bd	A9 Output Bd	A11 Reference Bd	A12 Synthesizer Bd	A14 Motherboard	A14BT1 Battery	A15 Daughterboard	A16 Line Module	A17 Rear Panel Bd	AT1 Attenuator
ABUS ADC Cal					●						●					
Internal Source Cal					●				●		●					
VCO Bias Adjustment					●					●	●					
Lock Angle Adjustment					●					●	●					
Kv vs Frequency Cal					●					●	●					
AM Audio Path Offset					●			●	●		●					
Timebase DAC Cal					●				●		●					
FM Scale DAC Offset Cal					●				●	●	●					
FM Path Offset Cal					●				●	●	●					
FM In-band DAC Offset Cal					●				●	●	●					
FM Invert Amp Offset Cal					●				●	●	●					
FM1/2 Path Ratio Gain Cal					●				●	●	●					
Mod Source Relative Gain Cal					●				●	●	●					
FM Delay Pot Adjustment					●				●	●	●					
Wide BW FM Cal					●				●	●	●					
DCFM Cal					●				●	●	●	●				
Peak Detector Cal					●				●	●	●					
Normal Mode PM Cal					●				●	●	●					
Burst Modulator Cal					●			●			●					
FM Out-of Band Cal					●				●	●	●					

6 Error Messages

This chapter explains the error messages that might be shown on the front panel display or transmitted over the interface bus.

Error Messages

If an error condition occurs in the signal generator, it will always be reported to both the front panel display error queue and the SCPI (remote interface) error queue. These two queues are viewed and managed separately.

The Front Panel Error Queue

This queue is designed in a circular (rotating) fashion. It can hold up to 30 error messages. If the queue is full, and additional error messages arrive, the oldest errors are lost. The previously read messages are not cleared from the queue; they remain in the queue until they are overwritten by a new error message.

The front panel error queue information can be accessed by pressing **Utility, Error Info**. From the Error Info menu, you may choose from **View Previous Error Message**, **View Next Error Message**, or **Clear Error Queue(s)**. You can also use the RPG and the arrow keys to review the messages/

If there are any unviewed messages in the front panel error queue, the **ERR** annunciator will be activated on the signal generator's display. you can optionally rotate the RPG or use the arrow keys to view the error messages. To empty the queue, press **Utility, Error Info, Clear Error Queue(s)**.

There are some special error types called permanent errors. These include **unlock**, **ovencold**, **hi/lo**, etc. Permanent errors remain in the error queues until the error condition is cleared. Pressing **Utility, Error Info, Clear Error Queue(s)** will empty the front panel error queue, but the permanent errors will be re-reported if the error condition(s) still exist.

The SCPI Remote Interface Error Queue

This queue is constructed in a linear first-in/first-out fashion. It can hold up to 30 error messages. As errors and events are detected, they are placed in the queue. Unlike the front panel error queue, errors in this queue are not overwritten by the latest incoming error messages. If the queue overflows, the last error in the queue is replaced with the error:

-350,Queue overflow

When the queue overflows, the least recent errors remain in the queue, and the most recent error is discarded. Reading an error from the head of the queue removes that error from the queue, and opens a position in the tail of the queue for a new error, if one is subsequently detected.

When all the errors have been read from the queue, further error queries will return:

0, No error

The SCPI query **SYSTem:ERRor?** is used to view messages in the SCPI error queue. The error queue will be cleared when any of the following occur (IEEE 488.2, section 11.4.3.4):

- Upon power up
- Upon receipt of a ***CLS** command
- Upon reading the last item from the queue

In the SCPI error queue, the permanent errors are re-reported after the message 0, No error is read using the **SYSTem:ERRor?** query and after the ***CLS** command is executed.

Querying the Error Queue

The queue query message is a request for the next entry from the instrument's error queue. This queue contains an integer that can range from -32768 to 32767. Negative error numbers are reserved by the SCPI standard and are defined in this section. Positive error numbers are instrument-dependent. An error value of zero indicates that no error or event has occurred.

The signal generator responds to the **SYSTEM:ERROR?** (or **STATUS:QUEUE?**) query using the following form:

<error number>, <error description>

The **<error number>** is a unique error descriptor. Certain standard error numbers are described in this section. The **<error description>** is a short description of the error, (optionally) followed by additional information regarding the error. Short descriptions of the standard error numbers are described in this section. The information that follows the error message may contain corrective actions that should be followed to correct the error condition.

The **<device-dependent info>** section of the response may contain information which will allow you to determine the exact error and context. For example:

-131, Invalid suffix;FREQUENCY:CENT 2.0E+5 dBmV

The maximum string length of **<error description>** plus **<device-dependent info>** is 255 characters. The **<error description>** will be sent exactly as indicated in this document, including case.

If there has been no error, that is, if the queue is empty, the signal generator will respond with:

0, No error

If there has been more than one error, the instrument will respond with the first one in its queue. Subsequent responses to **SYSTEM:ERROR?** will continue with the queue until it is empty.

Error Numbers

The system-defined error numbers are chosen on an enumerated (“1 of N”) basis. The SCPI-defined error numbers and the <error_description> portions of the error query response are listed here. The first error described in each class (for example, -100, -200, -300, -400) is a “generic” error. In selecting the proper error number to report, more specific error codes are preferred.

Error Messages

No Error

No Error

This message indicates that the error queue contains no errors.

Error Number **Error Description** [description/explanation/examples]

0

No error

The queue is empty. Every error in the queue has been read or the queue was purposely cleared by power-on or *CLS.

SCPI Standard Error Messages

Error Message Description

The list of error messages in this chapter describes all of the SCPI error messages associated with signal generator operation. A sample error message description is provided below to help you understand how information will be presented in this section.

-222 **Data out of range;value clipped to lower limit.**

Indicates that the user has entered a deviation, depth or internal source frequency that is beyond the specified limits.

The following list explains each element of the sample error message listing shown above.

- **SCPI Error Number** - The standard SCPI error number (-222 in this example). Standard SCPI error numbers are always negative, with the exception of 0, **No error**.
- **SCPI Error Message** - The SCPI error message is **Data out of range;** in this example.
- **Detailed Description** - The information that appears after the semicolon (;) provides more detail as to the exact nature of the error. In this example, **value clipped to lower limit** tells you that you have entered a value outside the allowable range and the signal generator has changed the value so that it falls within the allowable limits. If no detailed description exists, it will be omitted from the error message.
- **Explanation/Action Required** - The text that appears below each error message listing contains an explanation of the error message and, in some cases, corrective actions that should be followed in order to correct the error condition. Though this information is not shown on the signal generator's display, it can be found in the following section.

Command Error

An error number in the range [-199 to -100] indicates that an IEEE 488.2 syntax error has been detected by the instrument's parser. The occurrence of any error in this class will cause the command error bit (bit 5) in the event status register (IEEE 488.2, section 11.5.1) to be set. If this bit is set, one of the following events has occurred:

- An IEEE 488.2 syntax error has been detected by the parser. That is, a control-to-device message was received which is in violation of the IEEE 488.2 standard. Possible violations include a data element which violates device listening formats or whose type is unacceptable to the device.
- An unrecognized header was received. Unrecognized headers include incorrect device-specific headers and incorrect or unimplemented IEEE 488.2 common commands.

Events that generate command errors will not generate execution errors, device-specific errors, or query errors; see the error definitions in this chapter.

Command Error Message Descriptions

This section lists the signal generator's command error messages and their associated descriptions.

Error Number	Error Description [description/explanation/examples]
-100	Command error This is a generic syntax error for devices that cannot detect more specific errors. The code indicates only that a command error as defined in IEE 488.2, 11.5.1.1.4 has occurred.
-101	Invalid character A syntactic command contains a character which is invalid for that type. For example, a header containing an ampersand, SETUP&. This error might be used in place of error numbers -114, -121, -141 and some others.
-102	Syntax error An unrecognized command or data type was encountered. For example, a string was received when the device does not accept strings.
-103	Invalid separator The parser was expecting a separator and encountered an illegal character. For example, the semicolon was omitted after a program message unit.

- 104** **Data type error**
The parser recognized a data element that is not allowed. For example, numeric or string data was expected, but block data was encountered.
- 105** **GET not allowed**
A Group Execute Trigger was received within a program message (see IEEE 488.2, 7.7). Correct the HP-IB controller program so that the **GET** does not occur within a line of HP-IB program code.
- 108** **Parameter not allowed**
More parameters were received than expected for the header. For example, the ***ESE** common command only accepts one parameter, so receiving ***ESE 0, 1** is not allowed.
- 109** **Missing parameter**
Fewer parameters were received than required for the header. For example, the ***ESE** common command requires one parameter, so receiving ***ESE** is not allowed.
- 110** **Command header error**
An error was detected in the header. This message is used when the device cannot detect the more specific errors described for errors -111 through -119.
- 111** **Header separator error**
A character which is not a legal header separator was encountered while parsing the header.
- 112** **Program mnemonic too long**
The header contains more than twelve characters (see IEEE 488.2, 7.6.1.4.1).
- 113** **Undefined header**
The header is syntactically correct, but it is undefined for this specific device. For example, ***XYZ** is not defined for any device.
- 114** **Header suffix out of range**
The value of a header suffix attached to a program mnemonic makes the header invalid.
- 120** **Numeric data error**
This error, as well as errors -121 through -129, are generated when parsing a data element which appears to be numeric, including non-decimal numeric types. This particular error message is used if the device cannot detect a more specific error.

Error Messages
Command Error

- 121** **Invalid character in number**
An invalid character for the data type being parsed was encountered. For example, an alpha in a decimal numeric or a "9" in octal data.
- 123** **Exponent too large**
The magnitude of an exponent was greater than 32000 (see IEEE 488.2, 7.7.2.4.1).
- 124** **Too many digits**
The mantissa of a decimal-numeric data element contained more than 255 digits excluding leading zeros (see IEEE 488.2, 7.7.2.4.1).
- 128** **Numeric data not allowed**
A legal numeric data element was received, but the device does not accept one in this position for the header.
- 130** **Suffix error**
This error, as well as errors -131 through -139, are generated when parsing a suffix. This particular error message is used if the device cannot detect a more specific error.
- 131** **Invalid suffix**
The suffix does not follow the syntax described in IEEE 488.2, 7.7.3.2, or the suffix is inappropriate for this device.
- 134** **Suffix too long**
The suffix contained more than twelve characters (see IEEE 488.2, 7.7.3.4).
- 138** **Suffix not allowed**
A suffix was encountered after a numeric element which does not allow suffixes.
- 140** **Character data error**
This error, as well as errors -141 through -149, are generated when parsing a character data element. This particular error message is used if the device cannot detect a more specific error.
- 141** **Invalid character data**
Either the character data element contains an invalid character or the particular element received is not valid for the header.
- 144** **Character data too long**
The character data element contains more that twelve characters (see IEEE 488.2, 7.7.1.4).

- 148** **Character data not allowed**
A legal character data element was encountered where prohibited by the device.
- 150** **String data error**
This error, as well as errors –151 through –159, are generated when parsing a string data element. This particular error message is used if the device cannot detect a more specific error.
- 151** **Invalid string data**
A string data element was expected, but was invalid (see IEEE 488.2, 7.7.5.2). For example, an **END** message was received before the terminal quote character.
- 158** **String data not allowed**
A string data element was encountered, but not allowed by the device at this point in the parsing.
- 160** **Block data error**
This error, as well as errors –161 through –169, are generated when parsing a block data element. This particular error message is used if the device cannot detect a more specific error.
- 161** **Invalid block data**
A block data element was expected, but was invalid (see IEEE 488.2, 7.7.6.2). For example, an **END** message was received before the end length was satisfied.
- 168** **Block data not allowed**
A legal block data element was encountered, but not allowed by the device at this point in the parsing.
- 170** **Expression data error**
This error, as well as errors –171 through –179, are generated when parsing an expression data element. This particular error message is used if the device cannot detect a more specific error.
- 171** **Invalid expression**
The expression data element was invalid (see IEEE 488.2, 7.7.7.2). For example, unmatched parentheses or an illegal character.
- 178** **Expression data not allowed**
A legal expression data was encountered, but was not allowed by the device at this point in parsing.

Error Messages
Command Error

- 180** **Macro error**
- This error, as well as errors –181 through –189, are generated when defining a macro or executing a macro. This particular error message is used if the device cannot detect a more specific error.
- 181** **Invalid outside macro definition**
- Indicates that a macro parameter placeholder (**\$<number>**) was encountered outside of a macro definition.
- 183** **Invalid inside macro definition**
- Indicates that the program message unit sequence, sent with a ***DDT** or a ***DMC** command, is syntactically invalid (see IEEE 488.2, 10.7.6.3).
- 184** **Macro parameter error**
- Indicates that a command inside the macro definition had the wrong number or type of parameters.

Execution Error

An error number in the range [-299 to -200] indicates that an error has been detected by the instrument's execution control block. The occurrence of any error in this class will cause the execution error bit (bit 4) in the event status register (IEEE 488.2, section 11.5.1) to be set. If this bit is set, one of the following events has occurred:

- A <PROGRAM DATA> element following a header was evaluated by the device as outside of its legal input range or is otherwise inconsistent with the device's capabilities.
- A valid program message could not be properly executed due to some device condition.

Execution errors will be reported by the device after rounding and expression evaluation operations have been completed. Rounding a numeric data element, for example, will not be reported as an execution error. Events that generate execution errors will not generate command errors, device-specific errors, or query errors; see the error definitions in this chapter.

Execution Error Message Descriptions

This section lists the signal generator's execution error messages and their associated descriptions.

Error Number **Error Description** [description/explanation/examples]

-200	Execution Error This is a generic syntax error for devices that cannot detect more specific errors. The code indicates only that an execution error as defined in IEEE 488.2, 11.5.1.1.5 has occurred.
-201	Invalid while in local Indicates that a command is not executable while the device is in local mode due to a hard local control (see IEEE 488.2, 5.6.1.5). For example, a device with a rotary switch receives a message which would change the switch's state, but the device is in local so the message cannot be executed.
-202	Settings lost due to rtl Indicates that a setting associated with a hard local control (see IEEE 488.2, 5.6.1.5) was lost when the device changed to LOCS from REMS or to LWLS from RWLS.
-210	Trigger error Indicates that a GET , *TRG , or a triggering signal could not be executed due to an error.

Error Messages
Execution Error

- 211** **Trigger ignored**
- Indicates that a **GET**, ***TRG**, or triggering signal was received and recognized by the device, but was ignored because of device timing considerations. For example, the device was not ready to respond.
- 212** **Arm ignored**
- Indicates that an arming signal was received and recognized by the device but was ignored.
- 213** **Init ignored**
- Indicates that a request for a measurement initiation was ignored as another measurement was already in progress.
- 214** **Trigger deadlock**
- Indicates that a trigger source for the initiation of a measurement is set to **GET** and a subsequent measurement query is received. The measurement cannot begin until a **GET** is received, but the **GET** would cause an **INTERRUPTED** error.
- 215** **Arm deadlock**
- Indicates that the arm source for the initiation of a measurement is set to **GET** and a subsequent measurement query is received. The measurement cannot begin until a **GET** is received, but the **GET** would cause an **INTERRUPTED** error.
- 220** **Parameter error**
- Indicates that a program data element related error has occurred. This particular error message is used if the device cannot detect a more specific errors described for errors -221 through -229.
- 221** **Settings conflict**
- Indicates that a legal program data element was parsed but could not be executed due to the current device state (see IEEE 488.2 11.5.1.1.5).
- 222** **Data out of range**
- Indicates that a legal program data element was parsed but could not be executed because the interpreted value was outside the legal range defined by the device (see IEEE 488.2 11.5.1.1.5).
- 223** **Too much data**
- Indicates that a legal program data element of block, expression or string type was received that contained more data than the device could handle due to memory or related device-specific requirements.

- 224** **Illegal parameter value**
Used where exact value, from a list of possibilities, was expected.
- 225** **Out of memory**
The device has insufficient memory to perform the requested operation.
- 226** **Lists not same length**
Attempted to use LIST structure having individual LISTS of unequal length.
- 230** **Data corrupt or stale**
Possibly invalid data. A new reading was started but not completed since last access.
- 231** **Data questionable**
Indicates that the measurement accuracy is questionable.
- 232** **Invalid format**
Indicates that a legal program data element was parsed but could not be executed because the data format or structure is inappropriate. For example, when loading memory tables or when sending a **SYSTEM:SET** parameter for an unknown instrument.
- 233** **Invalid version**
Indicates that a legal program data element was parsed but could not be executed because the version of the data is incorrect to the device. This particular error is used when file or block data elements are recognized by the instrument, but cannot be executed for reasons of version incompatibility. For example, a non-supported file version or a non-supported instrument version.
- 240** **Hardware error**
Indicates that a legal program command or query could not be executed because of a hardware problem in the device. The definition of what constitutes a hardware problem is completely device-specific. This error is used when the device cannot detect the more specific errors described for errors -241 through -249.
- 241** **Hardware missing**
Indicates that a legal program command or query could not be executed because of missing device hardware. For example, an option was not installed.
- 250** **Mass storage error**
Indicates that a mass storage error has occurred. This message is used when a device cannot detect the more specific errors described for errors -251 through -259.

Error Messages
Execution Error

- 252** **Missing media**
- Indicates that a legal program command or query could not be executed because of missing media, for instance no disk in the disk drive. The definition of what constitutes missing media is device-specific.
- 253** **Corrupt media**
- Indicates that a legal program command or query could not be executed because of corrupt media, for instance a bad disk or incorrect disk format. The definition of what constitutes corrupt media is device-specific.
- 254** **Media full**
- Indicates that a legal program command or query could not be executed because the media was full. For example, there is was no space left on the disk. The definition of what constitutes full media is device-specific.
- 255** **Directory full**
- Indicates that a legal program command or query could not be executed because the media directory was full. The definition of what constitutes a full media directory is device-specific.
- 256** **File name not found**
- Indicates that a legal program command or query could not be executed because the file name on the device media could not be found. For example, an attempt was made to read or copy a nonexistent file. The definition of what constitutes a file not being found is device-specific.
- 257** **File name error**
- Indicates that a legal program command or query could not be executed because a file name on the device media was in error. For example, an attempt was made to copy to a duplicate filename. The definition of what constitutes a file name error is device-specific.
- 258** **Media protected**
- Indicates that the device or user has attempted to write to a read-only memory subsystem (msus). The definition of a protected media is device-specific.
- 260** **Expression error**
- Indicates that an expression data element-related error occurred. This error message is used when the device cannot detect the more specific errors described for errors -261 through -269.

- 261** **Math error in expression**
- Indicates that a syntactically legal expression program data element could not be executed due to a math error. For example, a divide-by-zero was attempted. The definition of a math error is device-specific.
- 270** **Macro error**
- Indicates that a macro-related execution error occurred. This error message is used when the device cannot detect the more specific errors described for errors -271 through -279.
- 271** **Macro syntax error**
- Indicates that a syntactically legal macro program data sequence, written in accordance with IEEE 488.2, 10.7.2, could not be executed due to a syntax error within the macro definition (see IEEE 488.2, 10.7.6.3).
- 272** **Macro execution error**
- Indicates that a syntactically legal macro program data sequence could not be executed due to an error within the macro definition (see IEEE 488.2, 10.7.6.3).
- 273** **Illegal macro label**
- Indicates that the macro label defined in the *DMC command was a legal string syntax, but could not be accepted by the device (see IEEE 488.2, 10.7.3 and 10.7.6.2). For example, the label was too long, the same as a common command header, or contained invalid header syntax.
- 274** **Macro parameter error**
- Indicates that the macro definition improperly used a macro parameter placeholder (see IEEE 488.2, 10.7.3).
- 275** **Macro definition too long**
- Indicates that a syntactically legal macro program data sequence could not be executed because the string or block contents were too long for the device to handle (see IEEE 488.2, 10.7.6.1).
- 276** **Macro recursion error**
- Indicates that a syntactically legal macro program data sequence could not be executed because the device found it to be recursive (see IEEE 488.2, 10.7.6.4).
- 277** **Macro redefinition not allowed**
- Indicates that the macro label defined in the *DMC command could not be executed because the macro label was already defined (see IEEE 488.2, 10.7.6.4).

Error Messages
Execution Error

- 278 Macro header not found**
Indicates that a syntactically legal macro label in the *GMC? query could not be executed because the header was not previously defined.
- 280 Program error**
Indicates that a downloaded program-related execution error occurred. This error message is used when the device cannot detect the more specific errors described for errors -281 through -289. The syntax used in a program and the mechanism for downloading a program is device-specific.
- 281 Cannot create program**
Indicates that an attempt to create a program was unsuccessful. This may be due to insufficient memory.
- 282 Illegal program name**
Indicates that the name used to reference a program was invalid. For example, redefining an existing program, deleting a nonexistent program, or in general, referencing a nonexistent program.
- 283 Illegal variable name**
Indicates that an attempt was made to reference a nonexistent variable.
- 284 Program currently running**
Indicates that certain operation related to programs may be illegal while the program is running. For example, deleting a running program may be illegal.
- 285 Program syntax error**
Indicates that a syntax error appears within a downloaded program. The syntax used when parsing a downloaded program is device-specific.
- 286 Program runtime error**
Indicates that a runtime error was detected in a downloaded program.
- 290 Memory use error**
Indicates that a user request has directly or indirectly caused an error related to memory or <data_handles>. This is not the same as "bad" memory.
- 291 Out of memory**
A downloaded program required more memory than was available in the instrument.

- 292** **Referenced name does not exist**
A downloaded program attempted to access an undefined element (a variable, constant, filename, etc.).
- 293** **Referenced name already exists**
A downloaded program attempted to define an element (a variable, constant, filename, etc.) that had already been defined.
- 294** **Incompatible type**
Indicates that the type or structure of a memory item is inadequate.

Device-specific Error

An error number in the range [-399 to -300] or [1 to 32767] indicates that the instrument has detected an error which is not a command error, a query error, or an execution error; some device operations did not properly complete, possibly due to an abnormal hardware or firmware condition. These codes are also used for self-test response errors. The occurrence of any error in this class will cause the device-specific error bit (bit 3) in the event status register (IEEE 488.2, section 11.5.1) to be set.

NOTE: For positive error number descriptions see the section titled “ESG-D Series Signal Generator Instrument-Specific Error Messages.”

The meaning of positive error codes is device-dependent and may be enumerated or bit mapped. The <error_message> string for positive error codes is not defined by SCPI. The occurrence of any error in this class will cause the device-specific error bit (bit 3) in the event status register (IEEE 488.2, section 11.5.1) to be set. Events that generate device-specific errors will not generate command errors, or query errors; see the other error definitions in this section.

Device-Specific Error Message Descriptions

This section lists the signal generator’s device-specific error messages and their associated descriptions.

Error Number	Error Description [description/explanation/examples]
-300	Device-specific error This is a generic device-dependent error for devices that cannot detect more specific errors. The code indicates only that a device-dependent error as defined in IEEE 488.2, 11.5.1.1.6 has occurred.
-310	System error Indicates that an error, termed “system error” by the device, has occurred.
-311	Memory error Indicates that an error was detected in the device’s memory.
-312	PUD memory lost Indicates that the protected user data saved by the *PUD command has been lost.
-313	Calibration memory lost Indicates that non-volatile calibration data has been lost.

- 314** **Save/recall memory loss**
Indicates that the non-volatile data saved by the ***SAV?** command has been lost.
- 315** **Configuration memory lost**
Indicates that non-volatile configuration data saved by the device has been lost. The meaning of this error is device-dependent.
- 320** **Storage fault**
Indicates that the firmware detected a fault when using data storage. This error is not an indication of physical damage or failure of any mass storage element.
- 321** **Out of memory**
Indicates that an internal operation needed more memory than was available.
- 330** **Self-test failed**
Indicates that the device has detected a failure during its self-test procedure.
- 340** **Calibration failed**
Indicates that the device has detected a failure during its calibration procedure.
- 350** **Queue overflow**
This is a specific code entered into the queue in lieu of the code that caused the error. This message indicates that there is no more room in the queue and an error occurred but was not recorded.
- 360** **Communication error**
This is the generic communication error for devices that cannot detect the more specific errors described for errors -361 through -363.
- 361** **Parity error in program message**
Indicates that the parity bit was not correct when data was received (for example, an incorrect parity bit on a serial port).
- 362** **Framing error in program message**
Indicates that a stop bit was not detected when data was received (for example, a baud rate mismatch).

Query Error

An error number in the range [-499 to -400] indicates that the output queue control of the instrument has detected a problem with the message exchange protocol described in IEEE 488.2, chapter 6. The occurrence of any error in this class will cause the query error bit (bit 2) to be set in the event status register (IEEE 488.2, section 11.5.1). These errors correspond to message exchange protocol errors described in IEEE 488.2, 6.5. If a query error occurs one of the following is true:

- An attempt is being made to read data from the output queue when no output is either present or pending.
- Data in the output queue has been lost.

Events that generate query errors will not generate command errors, execution errors, or device-specific errors; see the other error definitions in this section.

Query Error Message Descriptions

This section lists the signal generator's query error messages and their associated descriptions.

Error Number	Error Description [description/explanation/examples]
-400	<p>Query Error</p> <p>This is a generic query error for devices that cannot detect more specific errors. The code indicates only that a query error as defined in IEE 488.2, 11.5.1.1.7 and 6.3 has occurred.</p>
-410	<p>Query INTERRUPTED</p> <p>Indicates that a condition causing an INTERRUPTED query error occurred (see IEEE 488.2, 6.3.2.7). For example, a query was followed by DAB or GET before a response was completely sent.</p>
-420	<p>Query UNTERMINATED</p> <p>Indicates that a condition causing an UNTERMINATED query error occurred (see IEEE 488.2, 6.3.2.2). For example, the device was addressed to talk and an incomplete program message was received.</p>
-430	<p>Query DEADLOCKED</p> <p>Indicates that a condition causing a DEADLOCKED query error occurred (see IEEE 488.2, 6.3.1.7). For example, both the input buffer and the output buffer are full and the device cannot continue.</p>

-440

Query UNTERMINATED after indefinite response

Indicates that a query was received in the same program message after a query requesting an indefinite response was executed (see IEEE 488.2, 6.3.7.5).

ESG-D Series Signal Generator Instrument-Specific Error Messages

Some instrument-specific error messages incorporate the negative or “generic” SCPI error number with the addition of device-dependent/instrument-specific (ESG-D Series signal generator-specific) information following the semicolon in the error message.

A positive error number indicates that the instrument has detected an error within the HP-IB system, within the instrument’s firmware or hardware, during the transfer of block data, or during calibration.

Error Number Error Description [description/explanation/examples]

- 100** **Command error;R0:No standby mode allowed.**
Indicates that, in HP 8656/57 compatibility mode, R0 was received via HP-IB. This command is not supported by the compatibility mode.
Command error;Remote active function DN/UP not available.
Indicates that, in HP 8656/57 compatibility mode, either DN or UP was received via HP-IB. These commands are not supported by the compatibility mode.
Command error;LO: No low bandwidth ALC mode allowed.
Indicates that, in HP 8656/57 compatibility mode, LO was received via HP-IB. This command is not supported by the compatibility mode.
- 102** **Syntax error;Bad HP compatibility language character <character>.**
Indicates that, in HP 8656/57 compatibility mode, illegal language input was received.
Syntax error;Bad HP compatibility language token <token>.
Indicates that, in HP 8656/57 compatibility mode, a known command or termination specifier was received when it was not expected. For example, a termination specifier was received with no currently active function.
- 213** **Init ignored;Unable to sweep due to sweep being in an error state. The sweep error should be fixed.**
Indicates that the number of list, power, and/or dwell points are in conflict, or a serious system error has occurred in list/sweep. A previous error report should have described the error that is stalling list/sweep.
Init ignored;Cannot initiate sweep in manual mode.
Indicates that the manual mode is on and therefore the instrument cannot sweep.

Init ignored;Sweep is already initiated.

Indicates that the list/sweep is currently initiated and sweeping, therefore the command is not legal according to SCPI.

Init ignored;Sweep is already continuously initiated.

Indicates that the list/sweep is continuously initiated and sweeping, therefore the command is not legal according to SCPI.

-221

Settings conflict;Cannot have uplink protocols while the control frame is on. Frames 1-17 timeslots changed to downlink.

Indicates that, in TETRA mode, some of the timeslots are set to uplink. When the control frame is turned on in TETRA, all timeslots in all frames must use downlink protocols. The instrument enforces this by reconfiguring the timeslots that are not using downlink protocols when the control frame is switched on.

Settings conflict;Cannot select uplink protocols while the control frame is on. Selection changed to custom.

Indicates that in TETRA mode, an attempt has been made to select uplink protocols while the control frame is switched on. TETRA requires that the control frame be switched off in order to select uplink protocols.

Settings conflict;Continuous protocol timeslots cannot be turned off.

Indicates that a continuous protocol timeslot is switched off while in TETRA mode. When a continuous protocol has been selected for a timeslot in TETRA mode, all of the timeslots must be switched on.

Settings conflict;Continuous & Discontinuous setting conflict. All selected Continuous timeslots are now switched to Discontinuous.

Indicates that while in TETRA mode, an attempt has been made to simultaneously assign continuous and discontinuous protocols to the timeslots. Continuous and discontinuous protocols cannot coexist in TETRA mode. If a discontinuous protocol is selected for any timeslot, all timeslots' protocols are changed to discontinuous protocols.

Settings conflict;Discontinuous & Continuous setting conflict. All selected Discontinuous timeslots are now switched to Continuous.

Indicates that while in TETRA mode, an attempt has been made to simultaneously assign discontinuous and continuous protocols to the timeslots. Discontinuous and

continuous protocols cannot coexist in TETRA mode. If a continuous protocol is selected for any timeslot, all timeslots' protocols are changed to continuous protocols.

Settings conflict; Frequency list and dwell list are of unequal size. Set one list equal to size one, or make their sizes equal.

Indicates that the frequency list has more than one element and the dwell list has more than one element, and they are not of equal size. If any of the frequency, power, or dwell lists have more than one element, they must all have the same number of elements. A list of a single element is the same as a list of equal size with the single element repeated the necessary number of times.

Settings conflict; Frequency list and power list are of unequal size. Turn one list off, set one to size one, or make their sizes equal.

Indicates that the frequency list has more than one element and the power list has more than one element, and they are not of equal size. If any of the frequency, power, or dwell lists have more than one element, they must all have the same number of elements. A list of a single element is the same as a list of equal size with the single element repeated the necessary number of times.

Settings conflict; Power list and dwell list are of unequal size. Set one to size one, or make their sizes equal.

Indicates that the dwell list has more than one element and the power list has more than one element, and they are not of equal size. If any of the frequency, power, or dwell lists have more than one element, they must all have the same number of elements. A list of a single element is the same as a list of equal size with the single element repeated the necessary number of times.

Settings conflict; The selected external trigger setting conflicts with the previous setting.

Indicates that the external trigger has been set to positive edge for one trigger source and negative edge for another trigger source.

Settings conflict; I/Q & AM WB cannot be on at the same time.

The modulation types I/Q and AM WB cannot be used at the same time. This error is reported when the user attempts to activate one type of modulation while the other is activated. The modulation type that was most recently requested will be turned on and the modulation that was on at the time will be turned off.

Settings conflict; FM2/PM2 value set greater than FM1/PM1 value. FM1/PM1 changed to match FM2/PM2 value.

The deviation of FM2/PM2 must always be less than or equal to the deviation settings

for FM1/PM1. This error will be reported to the queue when FM1/PM1 is enabled and FM2/PM2 is also enabled and an adjustment to either FM2/PM2 deviation causes the FM2 or PM2 deviation to be greater than the FM1 or PM1 deviation. It will also be reported when FM2/PM2 is being turned on, and the last FM1/PM1 deviation setting is less than the current FM2/PM2 deviation setting. In both cases the FM1/PM1 deviation will be adjusted to match the FM2/PM2 deviation.

Settings conflict;FM1/PM1 value set less than FM2/PM2 value. FM2/PM2 changed to match FM1/PM1 value.

The deviation of FM2/PM2 must always be less than or equal to the deviation settings for FM1/PM1. This error will be reported to the queue when FM2/PM2 is enabled and FM1/PM1 is also enabled and an adjustment to either FM1/PM1 deviation causes the FM1 or PM1 deviation to be less than the FM2 or PM2 deviation. It will also be reported when FM1/PM1 is being turned on, and the last FM2/PM2 deviation setting is greater than the current FM1/PM1 deviation setting. In both cases the FM2/PM2 deviation will be adjusted to match the FM1/PM1 deviation.

Settings conflict;Enabled mod source conflicts with previously enabled mod source. Previous mod disabled.

The signal generator has three sources: INT, EXT1, and EXT2 that are shared by the FM1/PM1, AM1/AM2, FM2/PM2, pulse (INT and EXT2), and burst envelope (EXT1 only). Each source can only be used by one of the modulations at a time. If a source is being used by an active modulation, and a request for the source is made by another modulation, the first modulation will be turned off, the second modulation will be turned on.

Settings conflict;External burst cannot be on while using AM.

Indicates that there is a hardware conflict for the burst envelope using the EXT1 source (I/Q menu) and AM1/AM2. The most recently requested modulation will be turned on, the previous modulation will be turned off.

Settings conflict;FM & PM not allowed.

Indicates that there is a hardware conflict between FM and PM. The most recently requested modulation will be turned on, the previous modulation will be turned off.

Settings conflict;Pulse modulation cannot be on with internal burst.

Indicates that there is a hardware conflict between pulse modulation and internal burst. The most recently requested modulation will be turned on, the previous modulation will be turned off.

Settings conflict; Internal burst cannot be on with pulse modulation.

Indicates that there is a hardware conflict between internal burst and pulse modulation. The most recently requested modulation will be turned on, the previous modulation will be turned off.

Settings conflict; Pattern repeat is changed to continuous because data source is external.

Indicates that, while in non-bursted data generation, Pattern Repeat was in Single mode and data source was selected to be External. For non-bursted data generation using an external data source, Pattern Repeat must be in Continuous mode. To continue data transmission, Pattern repeat has been changed to Continuous mode.

Settings conflict; Uplink & Downlink setting conflict. All selected Uplink timeslots are now set to Downlink.

Indicates that an Uplink timeslot type has been selected while another timeslot(s) has Downlink selected. In NADC and PDC digital modulation for bursted data, only either Uplink (base to mobile) or Downlink (mobile to base) Traffic Channel type can be selected for all timeslots at any one moment. To continue data transmission, all Uplink timeslots have been changed to the Downlink configuration.

Settings conflict; Downlink & Uplink setting conflict. All selected Downlink timeslots are now set to Uplink.

Indicates that an Downlink timeslot type has been selected while another timeslot(s) has Uplink selected. In NADC and PDC digital modulation for bursted data, only either Uplink (base to mobile) or Downlink (mobile to base) Traffic Channel type can be selected for all timeslots at any one moment. To continue data transmission, all Downlink timeslots have been changed to the Uplink configuration.

Settings conflict; Pulse period set less than pulse width. Pulse width changed to match period value.

Indicates that a pulse period has been entered which is smaller than the pulse width. The instrument automatically adjusts the pulse period to match the pulse width.

Settings conflict; PDC and NADC Custom protocols are now uplink protocols, so the timeslots with Custom selected were changed to Downlink Custom.

Indicates that, because PDC or NADC has downlink protocols selected and also has Custom in one or more timeslots, the timeslots with Custom are set to Downlink Custom. Otherwise, the timeslots with Custom are set to Uplink Custom. Downlink Custom has its own instrument state information for the Data type and Fix 4 value.

-222

Data out of range;value clipped to lower limit.

Indicates that an input value is below the minimum value allowed. Examples are: frequency setting, reference, or offset; output power; power reference and offset; modulation depth, deviation, or modulation source frequency; number of points and start/stop values for list mode; start/stop values for internal I/Q calibration; sequence or register values (save/recall); dwell time.

Data out of range;value clipped to upper limit.

Indicates that an input value is above the maximum value allowed. Examples are: frequency setting, reference, or offset; output power; power reference and offset; modulation depth, deviation, or modulation source frequency; number of points and start/stop values for list mode; start/stop values for internal I/Q calibration; sequence or register values (save/recall); dwell time.

Data out of range;Synthesizer: Frequency out of bounds.

Indicates that the instrument received an internal request for a frequency outside of its supported frequency range. Report the circumstances to the factory.

Data out of range;Manual point exceeds list sizes. Limiting to maximum point.

Indicates that the sweep/list manual point has been reassigned to a smaller number value due to the longest list decreasing in size or being turned off. Its new value is the length of the longest enabled list (frequency or power).

Data out of range;Manual point exceeds frequency list size. Limiting to maximum point.

Indicates that the sweep/list manual point has been reassigned to a smaller number value due to the longest list decreasing in size or being turned off. Its new value is the length of the frequency list which is the longest enabled list.

Data out of range;Manual point exceeds power list size. Limiting to maximum point.

Indicates that the sweep/list manual point has been reassigned to a smaller number value due to the longest list shrinking, or being turned off. Its new value is the length of the power list, which is the longest enabled list.

-223

Too Much Data;The number of list points exceeds the maximum allowed.

Indicates that a SCPI list has been entered that is longer than the maximum allowed length, which is also the maximum number of step points; too many points were given for a frequency, amplitude, or dwell time list. This error can also be caused by

Error Messages

ESG-D Series Signal Generator Instrument-Specific Error Messages

- attempting to copy items in the list editor when the list is already at its maximum length.
- 230** **Data corrupt or stale;RAM copy of <filename>.**
- The non-volatile RAM copy of a file is either corrupt or is out of date with the EEPROM master copy (if one exists). The system automatically re-initializes the file from EEPROM (if appropriate) or from a default algorithm. A potential cause is a failing backup battery.
- Data corrupt or stale;EEPROM copy of <filename>.**
- The EEPROM copy of a file is either corrupt or otherwise unusable. The system automatically updates the non-volatile RAM copy of the EEPROM copy using a default initialization. The actual EEPROM file is left as it is. Report this problem to the factory.
- 231** **Data questionable;RAM copy of <filename>.**
- Indicates that the non-volatile RAM copy of a file has a correctable error. The system automatically performs the correction. A potential cause is a failing backup battery.
- Data questionable;EEPROM copy of <filename>.**
- Indicates that the EEPROM copy of a file has a correctable error. The system automatically performs the correction. A potential cause is a failing EEPROM. Report this problem to the factory.
- 241** **Hardware missing; <card_name>**
- Indicates that a test communication to a hardware card failed. The instrument is most likely not functional. Contact the nearest HP Sales and Service office.
- Hardware missing; Installed option boards do not match configuration information.**
- Indicates that a set of option boards have been installed that do not match the information that was given to the instrument as part of the installation. If this is the result of a customer installed option, the wrong option was specified during installation. If this is seen at any other time, the likely cause is an EEPROM failure on the option card.
- 250** **Mass storage error; EEPROM write timeout on <filename>.**
- Indicates that the system was not able to program new data to an EEPROM. The system is still functional, but files written to EEPROM (such as updated calibration data) may be lost when the instrument's line power is cycled. Contact the nearest HP Sales and Service office.

- 253** **Corrupt media;User File System**
- Indicates that the main memory area used for storing instrument states and sequences as well as other data files is corrupt. The system will automatically clear and reconfigure this memory area. A potential cause is a failing backup battery. Another potential cause could be the loss of line power to the instrument in the middle of a write operation.
- Corrupt media;<media_name>**
- Indicates that a source media (possibly EEPROM) for a data file is corrupt. This error is usually seen in conjunction with errors concerning a certain file.
- 254** **Media full; Unable to delete saved state from non-volatile memory. No instrument state change.**
- Indicates that the state memory subsystem **STATE:** was unable to delete a register. You must free some memory by deleting a file or register using Catalog. Afterwards, try again.
- Media full; Save a state register ignored.**
- Indicates that the state memory subsystem **STATE:** did not have enough room to save a register. You must free some memory by deleting a file or register using Catalog. Afterwards, try again.
- Media full; Save a state register failed. State marked available.**
- Indicates that the state memory subsystem **STATE:** did not have enough room to save a register, so the register was lost and is now marked available. You must free some memory by deleting a file or register using Catalog. Afterwards, try again.
- 256** **File name not found;The internal list file was not found. There is no list data to return**
- Indicates that the **DWEL_FILE**, **FREQ_FILE**, or **POW_FILE** has been lost, so a new one will have to be created. These files are the persistent information for list/sweep mode. They contain the dwell list, the frequency list, or the power list. Invoking the list editor will recreate the missing file to a length of one element.
- 257** **File name error;Delete empty sequence <sequence_name>. Delete sequence ignored.**
- Indicates that the user has attempted to delete a sequence which is empty (all registers unused). This is informational only. Typically this error is reported (several times) when the "Delete All Sequences" command is executed.

File name error;Delete a non-saved state register. Delete register ignored.

Indicates that the user has attempted to delete a state which is empty (unused). This is informational only.

File name error;Directory does not support extenders.

Indicates that an extender, which is specified by an @ sign followed by a memory subsystem name, has been specified for an explicit memory subsystem which does not allow the @ notation. Only the default (:) memory subsystem allows extenders.

File name error;Empty filename

Indicates that a filename of " " was specified. This is not a legal filename.

File name error;Illegal extender

Indicates that an illegal memory subsystem name was used after the @. Supported values are @STATE and @LIST.

File name error;Illegal filename character

Indicates that an illegal character was used within a filename. \, :, @ and all non-printable ASCII characters are illegal in filenames.

File name error;Only one ":" is allowed.

Indicates that only one colon is allowed in any filename specification. The text before the colon is a user memory subsystem. The valid user choices are :, DEFAULT:, STATE:, and LIST:.

File name error;Only one "@" is allowed.

Indicates that only one @ is allowed in any filename specification. It specifies the memory subsystem that a user file actually resides in.

-286

Program runtime error;Floating-Point Exception

Indicates that a floating-point math error (such as a divide by zero) has been detected. The system will attempt to recover automatically. Report the circumstances to the nearest HP Sales and Service office.

-310

System error;RS232 buffer overflow: character lost.

Indicates that the RS232 buffer has been exceeded. The most recent character has been dropped.

- System error;Cannot change manual point until list mode error condition cleared.**
- An error is keeping the sweep/list from being able to set the frequency and/or power. Until the problem is addressed, the manual point cannot be changed.
- System error;Unable to determine which attenuator is installed.**
- Indicates that an invalid attenuator identification code has been detected. Possible causes include a loose attenuator control cable. The instrument will likely not produce the proper output power levels. Report this error to the factory.
- 311 Memory error;Unable to configure Save Recall registers from non-volatile memory. Save Recall registers re-initialized.**
- Indicates that saved states are no longer usable. Delete explicitly using Catalog.
- 315 Configuration memory lost;Persistent state preset. Using factory defaults.**
- Indicates that the persistent state has been forced to return to factory preset values.
- Configuration memory lost;Persistent state version is bad. Using factory defaults.**
- Indicates that the persistent state version is not recognized as valid and is assumed to be corrupt. The persistent state is reinitialized with the factory preset values.
- Configuration memory lost;Persistent state checksum is bad. Using factory defaults.**
- Indicates that the persistent state is corrupt and had to be reinitialized with the factory preset values.
- 321 Out of memory;Unable to verify instrument state file.**
- Indicates that an instrument state file could not be accessed and verified because of insufficient memory. Reduce the size of any sweep lists and try again.
- Out of memory;Memory catalog failed.**
- Indicates that there is not enough memory to complete a catalog listing. Reduce the size of any sweep lists and try again.
- Out of memory;Unable to display timeslot window.**
- Indicates that the instrument was unable to create part of the graphical user interface due to an inability to allocate memory (possibly due to fragmentation). Please report the circumstances to the factory. The instrument is still functional.

ESG-D Series Signal Generator Instrument-Specific Error Messages

Out of memory;Unable to display protocol window.

Indicates that the instrument was unable to create part of the graphical user interface due to an inability to allocate memory (possibly due to fragmentation). Please report the circumstances to the factory. The instrument is still functional.

Out of memory;Unable to display format window.

Indicates that the instrument was unable to create part of the graphical user interface due to an inability to allocate memory (possibly due to fragmentation). Please report the circumstances to the factory. The instrument is still functional.

Out of memory;Cannot uncompress file.

Indicates that a **STATE:** file cannot be uncompressed because there is not enough memory to run the decompression algorithm. Recall will fail and there will be no instrument state change. Reduce the size of any sweep lists and try again.

Out of memory;Cannot precalculate frequencies. Try fewer frequencies.

Indicates that memory was exhausted during frequency precalculation (used to speed the process of sweep/list mode). List mode cannot run until either fewer frequencies have been supplied or more memory becomes available and the same set of frequencies are sent again, **FREQ:MODE CW** is executed, or **:FREQ:MODE LIST** is executed.

Out of memory;Object Memory Area

Indicates that memory was exhausted during instrument power-on. Report the circumstances to the factory.

Out of memory;List formation

The device was unable to allocate space for a lookup table, such as for list mode precalculation. List mode cannot run until either fewer frequencies have been supplied or more memory becomes available and the same set of frequencies are sent again, **FREQ:MODE CW** is executed, or **:FREQ:MODE LIST** is executed.

Out of memory;PRBS xx/xx

There was not enough memory to apply a scramble to data for the baseband generator. In this case, the scramble is not applied to the generator.

Out of memory;Display system out of memory. An abnormal display may result. Memory consumption should be reduced.

There was not enough memory in the system to properly update the display. Some inconsistencies may be seen. The size of any list/sweep should be reduced, and the source should be preset to clear up any inconsistencies. Report the circumstances to the

nearest HP Sales and Service office.

Out of memory;Unable to check Data Generator memory.

There was not enough memory in the system to properly complete the data generator memory test. This does NOT imply a data generator memory failure. Check all other error messages to identify possible causes, discontinue list/sweep mode to free some memory, and repeat the test.

-330

Self-test failed;Power supply self-test failure

Indicates that the self-test for a particular power supply voltage has failed. The instrument is likely not functional. Contact the nearest HP Sales and Service office.

Self-test failed;EEPROM header checksum error <card_name>.

Indicates that the card identification header for a hardware card is incorrect. If the card is not properly identified, the instrument is likely to be non-functional. Contact the nearest HP Sales and Service office.

Self-test failed;Data Generator Memory Test @ 0x_____

Indicates that the data generator memory failed. Modulation data produced by the data generator may not be correct. However, if an **Unable to check Data Generator Memory** error was also seen, this result is not conclusive. The address of the first location that failed is reported. Contact the nearest HP Sales and Service office.

Self-test failed;Burst Generator Memory Test @ 0x_____

Indicates that the burst generator memory failed. Modulation data produced by the burst generator may not be correct. However, if an **Unable to check Burst Generator Memory** error was also seen, this result is not conclusive. The address of the first location that failed is reported. Contact the nearest HP Sales and Service office.

Self-test failed;Bad address position @ 0x_____

Indicates that the data generator memory failed. Modulation data produced by the data generator may not be correct. An address that appeared to have a failed address line was reported. Contact the nearest HP Sales and Service office.

Self-test failed;Chips ___, ___ aliased @ 0x_____

Indicates that the data generator memory failed. Modulation data produced by the data generator may not be correct. An address that appeared to be aliased across multiple memory chips has been reported. Contact the nearest HP Sales and Service office.

-430

Query DEADLOCKED

Indicates that a SCPI output queue has filled preventing further SCPI command

Error Messages

ESG-D Series Signal Generator Instrument-Specific Error Messages

execution, and there is no more room left in the corresponding SCPI input queue to accept a query to read from the output queue. The system automatically discards output to correct the deadlock.

201 **Bad file number;Unable to check Data Generator memory.**

Indicates that the instrument was not able to generate the pattern necessary to perform the data generator memory test. This does NOT imply a data generator memory failure. Report the problem to the factory.

208 **I/O error;Unable to delete saved state from non-volatile memory. No instrument state change.**

Indicates that a **STATE:** file could not be deleted due to the file not being found, file corruption, or another file-related problem. If the file is displayed by a memory catalog, delete it explicitly.

I/O error;Save a state register ignored.

Indicates that a **STATE:** file could not be saved due to insufficient space, file corruption, or another related problem.

I/O error;Delete empty sequence <sequence_name>. Delete sequence ignored.

Indicates that the user has attempted to delete a sequence that is empty. This error message is informational only. Typically, this error is reported several times when the "Delete All Sequences" command is executed. If the file is displayed by Catalog, delete explicitly.

I/O error;Delete a non-saved state register. Delete register ignored.

Indicates that the user has attempted to delete an unused (empty) state. This error message is informational only.

I/O error;Trailing zero found in <filename>. Fixing...

Indicates that a compressed state file has a zero at its end. This is a sign of file corruption. The device fixes the problem by concealing the zero such that it no longer triggers an error message. The file may be corrupt or unusable.

I/O error;Unable to recall from non-volatile memory. No instrument state change.

Indicates that the state file is not readable and the recall was aborted.

- 214** **Not owner;Unable to delete saved state from non-volatile memory.
No instrument state change.**
Indicates that the user has attempted to write to a read-only memory subsystem.
- 501** **Attenuator hold setting over range;Frequency change forced
attenuator adjust.**
Indicates that the firmware has changed the attenuator setting because, while in attenuator hold mode, a change in frequency setting has forced the ALC beyond its range.
Attenuator hold setting over range;Power set to lower limit.
Indicates that the firmware has changed the power setting to a value other than the requested value due to the fact that, while in attenuator hold mode, the user has requested a power setting that is below the ALC range for the attenuator setting. The power has been set to the lower limit.
Attenuator hold setting over range;Power set to upper limit.
Indicates that the firmware has changed the power setting to a value other than the requested value due to the fact that, while in attenuator hold mode, the user has requested a power setting that is above the ALC range for the attenuator setting.
- 508** **Synthesizer unlocked**
Indicates that the synthesizer is unlocked. Service may be needed.
- 509** **Output Section input overdrive**
Internal error: report to factory.
- 510** **I/Q Modulator overdrive**
Internal error: report to factory.
- 511** **Output unlevelled**
Indicates that the instrument's output is unlevelled.
- 512** **Reference unlocked**
Indicates that the instrument's reference is unlocked. If an external reference is connected, check the frequency and power. It is possible for this to occur during a poor connection/disconnection of an external reference. If this error reoccurs when no external reference is connected, the instrument may require service.

- 513** **Ret VCO unlocked**
- Indicates that the VCO used to generate output frequencies below 250 MHz is unlocked. The instrument may require service.
- 514** **Reference Oven cold**
- Indicates that the reference oven is not at the required operating temperature. This is normal if the instrument has been powered down for a while. If the error persists, the instrument may require service.
- 515** **Reference board: 10 Mhz reference signal bad or missing**
- Indicates that the instrument's reference is unlocked. If an external reference is connected, check the frequency and power. It is possible for this to occur during a poor connection/disconnection of an external reference. If this error reoccurs when no external reference is connected, the instrument may require service.
- 516** **Baseband Generator unlocked; refer to manual.**
- Indicates that the digital modulation board is unlocked. If this error occurs and the status indicator on the front panel is not on, the board is operational. There are legitimate reasons for the front panel indicator to be on: if External Data mode was selected and no clock was provided for the data clock input, or if there was an incorrect setting selected for data clock/symbol clock.
- 517** **Calibration failure;DCFM DC overrange**
- Indicates that the instrument was unable to perform a DCFM or DCΦM calibration due to the input signal being outside of the offset range that can be calibrated for.
- Calibration failure;Upgrade calibration failed. Data not stored.**
- Indicates that the calibration stage of the instrument upgrade was not executed successfully. The calibration data has not been stored. The upgrade is not functional. Contact the nearest HP Sales and Service office.
- Calibration failure;Cal aborted by user.**
- Indicates that, while executing the internal I/Q calibration, the user sent a DCAS over the HP-IB or pressed the **Abort** key on the front panel.
- Calibration failure;I/Q cal failed to allocate memory.**
- Indicates that, while executing the internal I/Q calibration, the attempt to allocate memory for the calibration failed.

Calibration failure; 'Marble Cal', 'Offset Cal', 'Other Cal',
'Gain Cal', 'BBG Cal'

Indicates that, while executing the internal I/Q calibration, a failure occurred during the section indicated.

600

RPP has tripped.

Indicates that the reverse power protection circuit has been triggered. Repeated tripping of this circuit can cause damage to the instrument.

601

Power search failed.

Indicates that, while executing power search, the level meter circuit failed to return a meaningful value. This event indicates that the power is in a range that the leveling loop cannot properly level. The power will be set to the last properly leveled power.

605

DSP FW download failed.

Indicates that the instrument's firmware was unable to successfully initialize the internal DSP. Report the circumstances to the nearest HP Sales and Service office.

606

DSP times out.

Indicates that the DSP failed to respond within the appropriate amount of time. Report the circumstances to the nearest HP Sales and Service office.

607

DSP returns error.

Indicates that the DSP is in an indeterminate state. Report the circumstances to the nearest HP Sales and Service office.

608

DSP in use by other process.

Indicates that the DSP is in an indeterminate state. Report the circumstances to the nearest HP Sales and Service office.

615

New wave shape changes limit for internal frequency; frequency changed to new limit.

When using the internal modulation source, the upper limit varies for the different waveforms. If the user changes the waveform when the internal source frequency is higher than that allowed for the new waveform, the frequency for the source will be changed, and the user informed of that change with this message.

617

Configuration error; Data Generator Memory configuration does not match installed board.

This indicates that the memory configuration for an option board does not match the known memory limits of the board. If this error has occurred as the result of a customer-

installed option, uninstall all options and then reinstall the correct options. If the error persists, contact the factory.

Configuration error; Installed option boards do not match configuration information.

This indicates that the option boards have not been properly installed in the instrument. Verify that the correct option boards have been installed in the correct slots. Reinstall the correct option. If the error persists, contact the factory.

Configuration error; Invalid Data Generator memory configuration.

This indicates that the memory configuration for an option board does not match the known memory limits of any supported option board. If this error has occurred as the result of a customer-installed option, uninstall all options and then reinstall the correct options. If the error persists, contact the factory.

Configuration error; Invalid option board configuration.

This indicates that an invalid combination of option boards has been configured. If this error has occurred as the result of a customer-installed option, uninstall all options and then reinstall the correct options. If the error persists, contact the factory.

700

State Save Recall Error; Recall aborted. Unable to recall the state from non-volatile memory.

This indicates that the state file was not readable, so the recall was aborted. If state file exists, delete explicitly using the memory catalog.

State Save Recall Error; Recalled state has a bad checksum. No instrument state change.

This indicates that the state file was corrupt or out-of-date, so the recall was ignored. If state file exists, delete explicitly using the memory catalog.

State Save Recall Error; Recall data different from FW revision. No instrument state change.

Indicates that an attempt was made to recall a state that was saved with an incompatible version of the instrument firmware. This typically occurs when a state file is copied from an instrument with a newer version of firmware to an instrument with an older version of firmware. Newer versions of instrument firmware can read older state files.

State Save Recall Error; Recall non-saved state register. Recall ignored.

Indicates that a recall was attempted for a state register that is unused. If state file exists, delete explicitly using catalog.

State Save Recall Error;Delete sequence <sequence_name> ignored.

Indicates that a **STATE:** file in a sequence that is being deleted could not be deleted due to the file not being found, data corruption, etc. If state file exists, delete explicitly using the memory catalog.

State Save Recall Error;The state file is from a different firmware revision that does not support comments.

Indicates that an attempt was made to write a comment to a state file revision that does not support comments. Comments in saved state files are not supported by the A.01.00 and A.01.01 releases of the instrument firmware.

Error Messages

ESG-D Series Signal Generator Instrument-Specific Error Messages



7 Options and Accessories

This chapter describes the options that can be ordered for your signal generator at the time of shipment, the options that can be retrofitted to your existing signal generator, and the accessories that you can order.

Signal Generator Options

This section describes the options available for your signal generator. You can order these options with your signal generator by ordering the option number shown, or you can order these options post-sales by requesting the HP part number that is provided.

Front Handles (Option 1CN)

This kit contains two handles and the necessary hardware to attach the handles to the front of the signal generator. Instructions for assembling the parts are included with the kit. To order this kit after receipt of your signal generator, order HP part number 5063-9227.

Rack Mount Flanges without Handles (Option 1CM)

This kit contains two flanges and the necessary hardware to rack mount the signal generator in an HP System II or System II Plus cabinet. Instructions for assembling the parts are included with the kit. To order this kit after receipt of your signal generator, order HP part number 5063-9214.

Rack Mount Flanges with Handles (Option 1CP)

This kit contains two handles, two flanges, and the necessary hardware to rack mount the signal generator in an HP System II or System II Plus cabinet. Instructions for assembling the parts are included with the kit. To order this kit after receipt of your signal generator, order HP part number 5063-9221.

Three Year Warranty (Option W30)

If you order Option W30 at the point of sale, you will receive a service contract that extends your return-to-HP repair benefits beyond the end of the warranty period for an additional two years. This additional support is not available as a post-sales option.

I/Q Baseband Generator (Option UN3)

If you order Option UN3 at the point of sale, your signal generator will include an I/Q baseband generator which makes the following digital modulation formats available: DECT, GSM, NADC, PDC, PHS, and TETRA. Pre-modulation filtering selections are provided and PRBS capability with 1 Mbyte of pattern RAM. In addition to providing the modulation formats for modulating data based on the specifications of the standards, framing management capabilities are also provided.

I/Q Baseband Generator (Option UN4)

If you order Option UN4 at the point of sale, your signal generator will include an I/Q baseband generator which makes the following digital modulation formats available: DECT, GSM, NADC, PDC, PHS, and TETRA. Pre-modulation filtering selections are provided and PRBS capability with 8 Mbytes of pattern RAM. In addition to providing the modulation formats for modulating data based on the specifications of the standards, framing management capabilities are also provided.

Move All Front Panel Connectors to Rear Panel (Option 1EM)

If you order Option 1EM at the point of sale, all of the front panel connectors will be moved to the rear panel. If you order Option 1EM in combination with Option UN3 or UN4, all of the front panel connectors will be moved to the rear panel and, in addition, some of the connectors will be changed from BNC to SMB connectors.

High Stability Timebase (Option 1E5)

If you order Option 1E5 at the point of sale, the standard timebase reference assembly will be replaced with a high-stability timebase reference assembly. The high-stability timebase reference assembly has improved specifications over the standard assembly including warranted specifications for aging rate. (The aging rate specification is typical for the standard assembly.)

Delete Standard Manual Set (Option 0B0)

All instruments are supplied with one complete manual set (HP part number E4400-90080) which includes the following documents:

- User's Guide (HP part number E4400-90081)
- Programming Guide (HP part number E4400-90082)
- Quick Reference Guide (HP part number E4400-90083)
- Calibration Guide (HP part number E4400-90084)

If you order Option 0B0, at the point of sale, you will receive your signal generator with no documentation. If you later decide to purchase the documentation, you can order individual manuals by requesting the part numbers listed or you can order the complete manual set by ordering HP part number E4400-90080.

Extra Manual Set (Option 0B1)

All instruments are supplied with one complete manual set (HP part number E4400-90080) which includes the following documents:

- User's Guide (HP part number E4400-90081)
- Programming Guide (HP part number E4400-90082)
- Quick Reference Guide (HP part number E4400-90083)
- Calibration Guide (HP part number E4400-90084)

If you order Option 0B1, at the point of sale, you will receive an additional set of this documentation. After shipment of your order, you can order additional copies of these documents by requesting the individual part numbers or you can order the complete set by ordering HP part number E4400-90080.

Note

Service documentation is not part of the standard manual set. The service documentation is available as Options 0BW, 0BV, and 0BX.

Assembly-Level Service Guide (Option 0BW)

All instruments are supplied with one complete manual set (HP part number E4400-90080) which includes the following documents:

- User's Guide (HP part number E4400-90081)
- Programming Guide (HP part number E4400-90082)
- Quick Reference Guide (HP part number E4400-90083)
- Calibration Guide (HP part number E4400-90084)

If you order Option 0BW, at the point of sale, you will also receive the service guide (HP part number E4400-90014). This document provides the information required to troubleshoot and repair the signal generator to the assembly level. After shipment of your order, you can order additional copies of any of these documents by requesting the individual part numbers.

Component-Level Information Package (Option 0BV)

All instruments are supplied with one complete manual set (HP part number E4400-90080) which includes the following documents:

- User's Guide (HP E4400-90081)
- Programming Guide (HP part number E4400-90082)
- Quick Reference Guide (HP part number E4400-90083)
- Calibration Guide (HP part number E4400-90084)

If you order Option 0BV, at the point of sale, you will also receive the component-level information package (HP part number E4400-90015.) This document provides schematics, component locator diagrams, and part lists for the signal generator. After shipment of your order, you can order additional copies of any of these documents by requesting the individual part numbers.

Assembly-Level Service Guide and Component-Level Information Package (Option 0BX)

All instruments are supplied with one complete manual set (HP part number E4400-90080) which includes the following documents:

- User's Guide (HP E4400-90081)
- Programming Guide (HP part number E4400-90082)
- Quick Reference Guide (HP part number E4400-90083)
- Calibration Guide (HP part number E4400-90084)

If you order Option 0BX, at the point of sale, you will also receive the service guide (HP part number E4400-90014) and the component-level information package (HP part number E4400-90015). These documents provide you with the information required to troubleshoot and repair the signal generator to the assembly level, and also with schematics, component locator diagrams, and parts lists for the signal generator. After shipment of your order, you can order additional copies of any of these documents by requesting the individual part numbers.

User's Guide - Traditional Chinese for Taiwan (Option AB0)

In addition to the standard English language manual set, if you order Option AB0, at the point of sale, you will receive, at no charge, a subset of the user's guide translated into traditional Chinese for Taiwan. After shipment of your order, you can order additional copies of this document by requesting HP part number E4400-90030. This document is not free of charge when you order it after shipment of your signal generator.

User's Guide - Korean (Option AB1)

In addition to the standard English language manual set, if you order Option AB1, at the point of sale, you will receive, at no charge, a subset of the user's guide translated into Korean. After shipment of your order, you can order additional copies of this document by requesting HP part number E4400-90029. This document is not free of charge when you order it after shipment of your signal generator.

User's Guide - Chinese (Option AB2)

In addition to the standard English language manual set, if you order Option AB2, at the point of sale, you will receive, at no charge, a subset of the user's guide translated into Chinese. After shipment of your order, you can order additional copies of this document by requesting HP part number E4400-90028. This document is not free of charge when you order it after shipment of your signal generator.

User's Guide - German (Option ABD)

In addition to the standard English language manual set, if you order Option ABD, at the point of sale, you will receive, at no charge, a subset of the user's guide translated into German. After shipment of your order, you can order additional copies of this document by requesting HP part number E4400-90033. This document is not free of charge when you order it after shipment of your signal generator.

User's Guide - Spanish (Option ABE)

In addition to the standard English language manual set, if you order Option ABE, at the point of sale, you will receive, at no charge, a subset of the user's guide translated into Spanish. After shipment of your order, you can order additional copies of this document by requesting HP part number E4400-90032. This document is not free of charge when you order it after shipment of your signal generator.

User's Guide - Japanese (Option ABJ)

In addition to the standard English language manual set, if you order Option ABJ at the point of sale, you will receive, at no charge, a subset of the user's guide translated into Japanese. After shipment of your order, you can order additional copies of this document by requesting HP part number E4400-90031. This document is not free of charge when you order it after shipment of your signal generator.

Signal Generator Accessories

This section describes the accessories for the signal generator that can be ordered at any time.

Transit Case (HP Part Number 9211-1296)

The transit case is a sturdy, carrying container designed to protect your signal generator from physical damage during transportation. The interior of the container is lined with compressible foam that is form-fitting to the exterior shape of the signal generator.

Remote Interface (HP 83300A)

The remote interface is an accessory to the signal generator consisting of a keypad which is connected by a 1 meter cable to the AUXILIARY INTERFACE rear panel connector (RS-232). This keypad lets you recall instrument states. (This is the same recall function provided by the front panel keys.) The remote interface is a convenient accessory for use in production environments where multiple instrument states are repetitively utilized.

RS-232 Cable Kit

This kit contains the appropriate hardware (cable, adapters, and null modem) to connect the signal generator RS-232 interface to a computer controller. This hardware will be required for downloading firmware from the HP SoCo Web site. To order this kit, request HP part number E4400-60049.

Upgrade and Retrofit Kits

This section describes the kits available for upgrading an existing signal generator feature and the kits available to retrofit a feature to your signal generator. You can order these kits post-sales by requesting the option number or the HP part number that is provided.

Firmware Upgrade Kit

This kit contains the latest firmware available for the signal generator. Disks are included in the kit in both DOS and UNIX formats. Instructions for downloading the firmware are included. To order this kit, request HP part number E4400-60046.

Firmware Upgrade Kit with Documentation

This kit contains the latest firmware available for the signal generator. Disks are provided in the kit in both DOS and UNIX formats. Instructions for downloading the firmware are included. In addition, the standard documentation set for the signal generator is provided. To order this kit, request HP part number E4400-60055.

Option 1EH to Option UN3 Upgrade Kit (Option 001)

This kit contains all of the hardware and the instructions to upgrade a signal generator from Option 1EH to Option UN3. Option 1EH is an I/Q baseband generator that is no longer available. Option UN3 contains the same I/Q baseband generator capability as Option 1EH with the addition of DECT and TETRA digital modulation formats, PRBS, 1 Mbyte of pattern RAM, and pre-modulation filtering. To order this kit, request HP part number E4400-60040 or order Option 001.

Option 1EH to Option UN4 Upgrade Kit (Option 002)

This kit contains all of the hardware and the instructions to upgrade a signal generator from Option 1EH to Option UN4. Option 1EH is an I/Q baseband generator that is no longer available. Option UN4 contains the same I/Q baseband generator capability as Option 1EH with the addition of DECT and TETRA digital modulation formats, PRBS, 8 Mbytes of pattern RAM, and pre-modulation filtering. To order this kit, request HP part number E4400-60056 or order Option 002.

Standard Digital to Option UN4 Retrofit Kit (Option 003)

This kit contains all of the hardware and the instructions to retrofit a standard digital version of the signal generator (HP ESG-DX000A) with Option UN4 (I/Q baseband generator with 8 Mbytes of pattern RAM). To order this kit, request HP part number E4400-60031 or order Option 003.

Options and Accessories
Upgrade and Retrofit Kits

8 Contacting Hewlett-Packard

This chapter prepares you for contacting Hewlett-Packard should you have a problem with your signal generator. This chapter is organized into the following sections:

- Before Contacting HP
- Calling HP Sales and Service Offices
- Returning Your Signal Generator for Service
- Blue Repair Tags

Before Contacting HP

Check the Basics

Often problems may be solved by repeating what was being done when the problem occurred. A few minutes spent in performing these simple checks may eliminate time spent waiting for instrument repair.

- Check that the signal generator is plugged into the proper ac power source.
- Check that the line socket has power.
- Check that the signal generator is turned on.
- Check that the other equipment, cables, and connectors are connected properly and operating correctly.
- Check the equipment settings in the procedure that was being used when the problem occurred.
- Check that the test being performed and the expected results are within the specifications and capabilities of the signal generator. (Refer to the *Calibration Guide*.)
- Check the signal generator display for error messages. (Refer to Chapter 6, "Error Messages.")
- Check operation by performing the verification procedures in the *Calibration Guide*. Record all results in the Performance Test record.

Review the Warranty

If there is still a problem, read the warranty printed in Chapter 9, "Safety and Regulatory." If your signal generator is covered by a separate maintenance agreement, please be familiar with its terms.

Hewlett-Packard offers several maintenance plans to service your signal generator after warranty expiration. Call your HP sales and service office for full details.

Returning Your Signal Generator for Service

Use the information in this section if you need to return the signal generator to Hewlett-Packard.

Packaging the Signal Generator

Use the following steps to package the signal generator for shipment to Hewlett-Packard for service:

1. Fill out a blue repair tag (available at the end of this chapter) and attach it to the instrument. Please be as specific as possible about the nature of the problem. Send a copy of any or all of the following information:
 - Any error messages that appeared on the signal generator display.
 - A completed performance test record from the calibration guide for your instrument.
 - Any other specific data on the performance of the signal generator.
2. Use the original packaging materials or a strong shipping container that is made of double-walled, corrugated cardboard with 159 kg (350 lb) bursting strength. The carton must be both large enough and strong enough to accommodate the signal generator and allow at least 3 to 4 inches on all sides of the signal generator for packing material.

CAUTION:

Signal generator damage can result from using packaging materials other than those specified. Never use styrene pellets, in any shape, as packaging materials. They do not adequately cushion the instrument or prevent it from shifting in the carton. Styrene pellets cause equipment damage by generating static electricity and by lodging in the signal generator fan.

3. Surround the instrument with at least 3 to 4 inches of packing material, or enough to prevent the instrument from moving in the carton. If packing foam is not available, the best alternative is SD-240 Air Cap™ from Sealed Air Corporation (Hayward, CA 94545). Air Cap looks like a plastic sheet covered with 1-1/4 inch air-filled bubbles. Use the pink Air Cap to reduce static electricity. Wrap the instrument several times in the material to both protect the instrument and prevent it from moving in the carton.
4. Seal the shipping container securely with strong, nylon adhesive tape.
5. Mark the shipping container "FRAGILE, HANDLE WITH CARE" to ensure careful handling.
6. Retain copies of all shipping papers.

Contacting Hewlett-Packard
Returning Your Signal Generator for Service



9 Safety and Regulatory

This chapter provides information on the following:

- general safety information
- lithium battery disposal
- warranty and legal information

Safety Notes

The following safety notes are used throughout this manual. Familiarize yourself with each of the notes and its meaning before operating this instrument.

CAUTION:

Caution denotes a hazard. It calls attention to a procedure that, if not correctly performed or adhered to, would result in damage to or destruction of the product. Do not proceed beyond a caution sign until the indicated conditions are fully understood and met.

WARNING:

Warning denotes a hazard. It calls attention to a procedure which, if not correctly performed or adhered to, could result in injury or loss of life. Do not proceed beyond a warning note until the indicated conditions are fully understood and met.

General Safety Considerations

The following safety notes apply specifically to HP ESG-D Series Signal Generators. These notes also appear in other chapters of this service guide as required.

WARNING: These servicing instructions are for use by qualified personal only. To avoid electrical shock, do not perform any servicing unless you are qualified to do so.

WARNING: The opening of covers or removal of parts is likely to expose dangerous voltages. Disconnect the product from all voltage sources while it is being opened.

WARNING: The detachable power cord is the instrument disconnecting device. It disconnects the mains circuits from the mains supply before other parts of the instrument. The front panel switch is only a standby switch and is not a LINE switch.

WARNING: The power cord is connected to internal capacitors that may remain live for 5 seconds after disconnecting the plug from its power supply.

WARNING: This is a Safety Class 1 Product (provided with a protective earthing ground incorporated in the power cord). The mains plug shall only be inserted in a socket outlet provided with a protective earth contact. Any interruption of the protective conductor inside or outside of the product is likely to make the product dangerous. Intentional interruption is prohibited.

CAUTION: Many of the assemblies in this instrument are very susceptible to damage from ESD (electrostatic discharge). Perform service procedures only at a static-safe workstation and wear a grounding strap.

Lithium Battery Disposal

When the battery on the A14 CPU/Motherboard is exhausted and/or ready for disposal, dispose of it according to your country's requirements. You can return the battery to your nearest Hewlett-Packard Sales and Service office for disposal, if required. (Refer to Chapter 8, "Contacting Hewlett-Packard," for a list of Hewlett-Packard Sales and Service offices.)

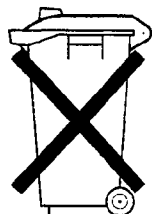

**DO NOT THROW BATTERIES AWAY BUT
COLLECT AS SMALL CHEMICAL WASTE.**

sk780a

Warranty

This Hewlett-Packard instrument product is warranted against defects in material and workmanship for a period of one year from date of shipment. During the warranty period, Hewlett-Packard Company will, at its option, either repair or replace products which prove to be defective.

For warranty service or repair, this product must be returned to a service facility designated by Hewlett-Packard. Buyer shall prepay shipping charges to Hewlett-Packard and Hewlett-Packard shall pay shipping charges to return the product to Buyer. However, Buyer shall pay all shipping charges, duties, and taxes for products returned to Hewlett-Packard from another country.

Hewlett-Packard warrants that its software and firmware designated by Hewlett-Packard for use with an instrument will execute its programming instructions when properly installed on that instrument. Hewlett-Packard does not warrant that the operation of the instrument, or software, or firmware will be uninterrupted or error-free.

LIMITATION OF WARRANTY

The foregoing warranty shall not apply to defects resulting from improper or inadequate maintenance by Buyer, Buyer-supplied software or interfacing, unauthorized modification or misuse, operation outside of the environmental specifications for the product, or improper site preparation or maintenance.

NO OTHER WARRANTY IS EXPRESSED OR IMPLIED. HEWLETT-PACKARD SPECIFICALLY DISCLAIMS THE IMPLIED WARRANTIES OF MERCHANTABILITY AND FITNESS FOR A PARTICULAR PURPOSE.

EXCLUSIVE REMEDIES

THE REMEDIES PROVIDED HEREIN ARE BUYER'S SOLE AND EXCLUSIVE REMEDIES. HEWLETT-PACKARD SHALL NOT BE LIABLE FOR ANY DIRECT, INDIRECT, SPECIAL, INCIDENTAL, OR CONSEQUENTIAL DAMAGES, WHETHER BASED ON CONTRACT, TORT, OR ANY OTHER LEGAL THEORY.

Assistance

Product maintenance agreements and other customer assistance agreements are available for Hewlett-Packard products. For any assistance, contact your nearest Hewlett-Packard sales and service office. (Refer to Chapter 8, "Contacting Hewlett-Packard.")

Notice

The information contained in this document is subject to change without notice.

Hewlett-Packard makes no warranty of any kind with regard to this material, including but not limited to, the implied warranties of merchantability and fitness for a particular purpose. Hewlett-Packard shall not be liable for errors contained herein or for incidental or consequential damages in connection with the furnishing, performance, or use of this material.

Certification

Hewlett-Packard Company certifies that this product met its published specifications at the time of shipment from the factory. Hewlett-Packard further certifies that its calibration measurements are traceable to the United States National Institute of Standards and Technology, to the extent allowed by the Institute's calibration facility, and to the calibration facilities of other International Standards Organization members.

Index

A

- A1 front panel board
 - HP part number, 3-12
 - removal and replacement, 4-22
- A11 reference board
 - block diagram, 2-11
 - HP part number, 3-10
 - node voltages, 2-9
 - removal and replacement, 4-44
- A12 synthesizer/doubler board
 - block diagram, 2-15
 - HP part number, 3-10
 - node voltages, 2-13
 - removal and replacement, 4-44
- A14 CPU/motherboard
 - block diagram, 2-19, 2-21
 - HP part number, 3-8
 - node voltages, 2-17
 - removal and replacement, 4-46
- A14BT1 battery
 - HP part number, 3-8
 - removal and replacement, 4-50
- A15 daughterboard
 - HP part number, 3-10
 - removal and replacement, 4-52
- A16 line module
 - HP part number, 3-14
 - removal and replacement, 4-56
- A17 rear panel interface
 - HP part number, 3-14
 - removal and replacement, 4-58
- A2 display
 - HP part number, 3-12
 - removal and replacement, 4-24
- A2DS1 fluorescent lamp
 - HP part number, 3-12
 - removal and replacement, 4-26
- A3 inverter
 - HP part number, 3-12
 - removal and replacement, 4-28
- A4 power supply
 - HP part number, 3-8
 - removal and replacement, 4-30, 4-34
- A7 baseband generator
 - block diagram, 2-25, 2-27
 - HP part number, 3-8
 - removal and replacement, 4-38, 4-40
- A8 data generator
 - block diagram, 2-29
 - HP part number, 3-8
 - removal and replacement, 4-42
- A9 output board
 - block diagram, 2-7
 - HP part number, 3-10
 - node voltages, 2-5

- removal and replacement, 4-44
 - abbreviations
 - options, 3-6
 - part descriptions, 3-6
 - reference designators, 3-6
 - accessories, 7-7
 - part numbers, 3-56
 - remote interface, 7-7
 - transit case, 7-7
 - add CLIP
 - add option, 7-5
 - add manual set
 - add option, 7-4
 - add service guide
 - add option, 7-4
 - add service guide and CLIP
 - add option, 7-5
 - add user's guide (Chinese)
 - add option, 7-6
 - add user's guide (German)
 - add option, 7-6
 - add user's guide (Japanese)
 - add option, 7-6
 - add user's guide (Korean)
 - add option, 7-6
 - add user's guide (Spanish)
 - add option, 7-6
 - add user's guide (Taiwanese)
 - add option, 7-5
- adjustments, 5-4
- antistatic materials, 3-57
- assemblies
 - defective, 3-4, 3-5
 - exchange, 3-4
 - part numbers, 3-8-3-15
 - rebuilt, 3-4
- assembly replacement
 - A1 front panel board, 4-22
 - A11 reference board, 4-44
 - A12 synthesizer/doubler board, 4-44
 - A14 CPU/motherboard, 4-46
 - A14BT1 battery, 4-50
 - A15 daughterboard, 4-52
 - A16 line module, 4-56
 - A17 rear panel interface (Options 1E5, UN3, UN4), 4-58
 - A2 display, 4-24
 - A2DS1 fluorescent lamp, 4-26
 - A3 inverter, 4-28
 - A4 power supply, 4-30
 - A4 power supply (Option 1EM), 4-34
 - A7 baseband generator (Option 1EH), 4-38
 - A7 baseband generator (Options UN3 & UN4), 4-40

- UN3 & UN4), 4-40
 - A8 data generator (Options UN3 & UN4), 4-42
 - A9 output board, 4-44
 - AT1 electronic attenuator/RPP, 4-60
 - B1 small fan, 4-62
 - B2 large fan, 4-64
 - front panel, 4-6
 - front panel (Option 1EM), 4-10
 - instrument cover, 4-4
 - list of replaceable assemblies, 4-3
 - post-repair procedures, 4-3
 - rear panel, 4-14
 - rear panel (Option 1EM), 4-18
 - semi-rigid cables, 4-66
 - assistance, 9-6
 - AT1 attenuator/RPP
 - block diagram, 2-23
 - AT1 electronic attenuator
 - HP part number, 3-8
- ## B
- B1 small fan
 - HP part number, 3-8
 - removal and replacement, 4-62
 - B2 large fan
 - HP part number, 3-8
 - removal and replacement, 4-64
 - battery
 - disposal of, 9-4
 - block diagrams
 - A11 reference board, 2-11
 - A12 synthesizer/doubler board, 2-15
 - A14 CPU/motherboard, 2-19, 2-21
 - A7 baseband generator (Option 1EH), 2-25
 - A7 baseband generator (Options UN3 & UN4), 2-27
 - A8 data generator (Options UN3 & UN4), 2-29
 - A9 output board, 2-7
 - AT1 attenuator/RPP, 2-23
 - interconnects, modulation and signal, 2-35, 2-37
 - interconnects, power supply and ground, 2-31, 2-33
 - overall, 1-17
 - overall (Option 1EH), 1-19
 - overall (Options UN3 & UN4), 1-21
 - blue repair tag, 8-7
- ## C
- cables
 - part numbers, 3-16-3-33

Index

- calling Hewlett-Packard, 8-3
 - cautions
 - defined, 9-2
 - listing of, 9-3
 - certification, 9-8
 - connectors moved to rear panel
 - add option, 7-3
 - contacting Hewlett-Packard, 8-1
 - copyright, i
 - D**
 - defective assemblies, 3-4
 - delete manual set
 - delete option, 7-3
 - documentation
 - part numbers, 3-56
 - E**
 - electrostatic discharge
 - preventing, 9-3
 - supplies, 3-57
 - error messages
 - command error, 6-8
 - description of, 6-7
 - device-specific error, 6-20
 - error numbers, 6-5
 - ESG-D series-specific, 6-24
 - execution error, 6-13
 - no error, 6-6
 - query error, 6-22
 - SCPI standard, 6-7
 - error queue
 - front panel, 6-2
 - querying, 6-4
 - SCPI remote interface, 6-2
 - ESD. *See* electrostatic discharge
 - exchange assemblies, 3-4
 - F**
 - firmware
 - upgrade kits, 3-57
 - front handles
 - add option, 7-2
 - front panel
 - removal and replacement, 4-6, 4-10
 - fuses, 1-5
 - H**
 - hardware
 - part numbers, 3-34-3-55
 - Hewlett-Packard
 - address, i
 - before you contact, 8-2
 - contacting, 8-1
 - shipping the signal generator to, 8-5
 - Hewlett-Packard Sales and Service Offices, 3-3, 8-3
 - high stability timebase
 - add option, 7-3
 - I**
 - initial troubleshooting, 1-1
 - instrument cover
 - removal and replacement, 4-4
 - L**
 - legal information, 9-1
 - lithium battery
 - disposal of, 9-4
 - M**
 - manual part number, i
 - manual part numbers, 3-56
 - manual print date, i
 - N**
 - NIST. *See* United States National Institute of Standards and Technology
 - O**
 - option 1CN, 7-2
 - option descriptions, 3-6
 - options, 7-2
 - OBO, 7-3
 - OB1, 7-4
 - OBV, 7-5
 - OBW, 7-4
 - OBX, 7-5
 - 1CM, 7-2
 - 1CP, 7-2
 - 1E5, 7-3
 - 1EM, 7-3
 - AB0, 7-5
 - AB1, 7-6
 - AB2, 7-6
 - ABD, 7-6
 - ABE, 7-6
 - ABJ, 7-6
 - add CLIP, 7-5
 - add manual set, 7-4
 - add service guide, 7-4
 - add service guide and CLIP, 7-5
 - add user's guide (Chinese), 7-6
 - add user's guide (German), 7-6
 - add user's guide (Japanese), 7-6
 - add user's guide (Korean), 7-6
 - add user's guide (Spanish), 7-6
 - add user's guide (Taiwanese), 7-5
 - connectors moved to rear panel, 7-3
 - delete manual set, 7-3
 - front handles, 7-2
 - high stability timebase, 7-3
 - rack mount flanges with handles, 7-2
 - rack mount flanges without handles, 7-2
 - three year warranty, 7-2
 - W30, 7-2
- ordering parts, 3-2
- P**
- packaging the signal generator, 8-5
- packaging your signal generator, 8-5
- part descriptions, 3-6
- part numbers. *See* replaceable parts
- performance tests, 5-2
- post-repair procedures, 5-1
 - adjustments, 5-4
 - performance tests, 5-2
- problems with your signal generator, 8-2
- R**
- rack mount flanges with handles
 - add option, 7-2
- rack mount flanges without handles
 - add option, 7-2
- rear panel
 - removal and replacement, 4-14, 4-18
- rebuilt assemblies, 3-4
- reference designators, 3-6
- remote interface, 7-7
- repair tag, 8-7
- replaceable assemblies, 4-3
- replaceable parts, 3-1
 - abbreviations, 3-6
 - accessories, 3-56
 - cables, 3-16-3-33
 - documentation, 3-56
 - ESD supplies, 3-57
 - hardware and other, 3-34-3-55
 - kits, 3-57
 - major assemblies, 3-8-3-15
 - manuals, 3-56
 - miscellaneous, 3-56
 - ordering information, 3-2
 - reference designators, 3-6
- replacing fuses, 1-5
- retrofit kits
 - part numbers, 3-57
- returning the signal generator, 8-5

Index

returning your signal generator, 8-5

S

safety and regulatory, 9-1
safety considerations, 9-3
sales offices. *See* Hewlett-Packard
Sales and Service Offices
semi-rigid cables
removal and replacement, 4-66
serial number prefix, i
service guide
use of, 1-3
service offices. *See* Hewlett-Packard
Sales and Service Offices
service tag, 8-7
servicing your signal generator, 8-5
shipping
defective assemblies, 3-5
exchange assemblies, 3-5
shipping the signal generator, 8-5
software, 2-3
static. *See* electrostatic discharge

T

three year warranty
add option, 7-2
title page, i
transit case, 7-7
troubleshooting
A11 reference board, 2-9
A12 synthesizer/doubler board, 2-13
A14 CPU/motherboard, 2-17
A9 output board, 2-5
assembly level, 2-1
before you begin, 1-2, 2-2
beginning, 1-1, 1-5
CPU functionality, 1-14
CPU/motherboard LEDs, 1-9, 1-14
equipment, 1-4
error messages, 1-7
front panel LEDs, 1-5
functional check, 1-8
initial, 1-1, 1-5
isolating the failed assembly, 1-13
measuring voltage supplies, 1-10
rear panel LEDs, 1-5
software, 2-3
using assembly-level procedures,
2-3
using this guide, 1-3

U

United States National Institute of
Standards and Technology, 9-8

upgrade kits
part numbers, 3-57

W

warnings
defined, 9-2
listing of, 9-3
warranty
reviewing, 8-2
warranty information, 9-5
regarding this document, 9-7



Order Part Number

E4400-90014

E0797

Printed in U.S.A.

Manufacturing Part Number

E4400-90014

